

**TECHNICAL MANUAL
OPERATOR'S MANUAL
FOR
CARRIER, CARGO TRACKED, 6-TON M548A1
2350-01-096-9356 (EIC AEU)
M548A3
2350-01-369-6081 (EIC AE9)**

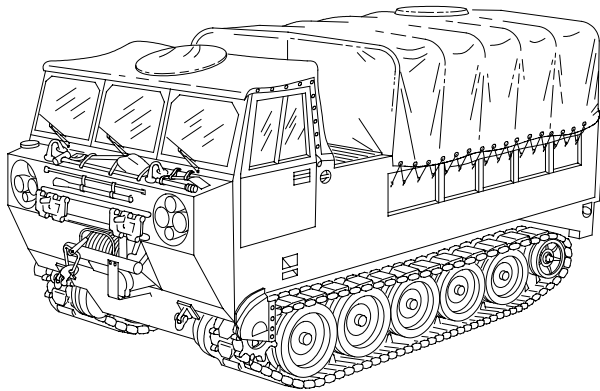

M548A1

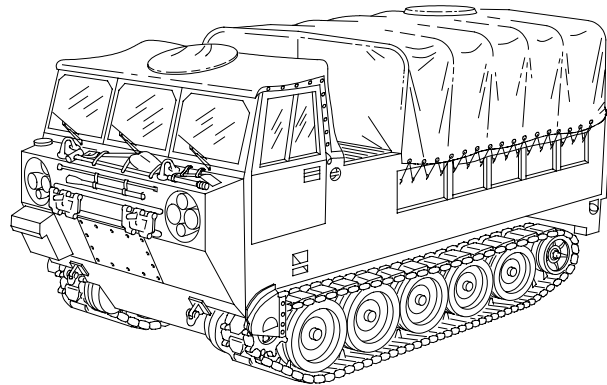

M548A3

SUPERSEDURE NOTICE — This manual supersedes TM 9-2350-247-10 dated August 1994, including all changes.

DISTRIBUTION STATEMENT A — Approved for public release; distribution is unlimited.

HEADQUARTERS, DEPARTMENT OF THE ARMY

30 June 2001

WARNING SUMMARY

WARNING SUMMARY

This list summarizes critical WARNINGS in this manual. They are repeated here to let you know how important they are. Study these WARNINGS carefully; they can save your life and the lives of personnel you work with.

WARNING

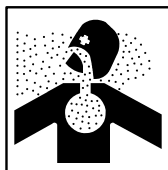

HEATER AND ENGINE EXHAUST FUMES CONTAIN DEADLY POISONOUS GASES.

SEVERE EXPOSURE CAN CAUSE DEATH OR PERMANENT BRAIN DAMAGE.

EXHAUST GASES ARE MOST DANGEROUS IN PLACES WITH POOR AIR FLOW.

To protect yourself and your partners, always obey the following rules:

Do not run heater or engine indoors unless you have VERY GOOD AIR FLOW.

Do not idle engine for a long time unless there is VERY GOOD AIR FLOW.

Do not drive carrier with any power plant access covers open or removed.

BE ALERT at all times. Check for the smell of exhaust fumes. If you notice any fumes, OPEN HATCH COVERS, RAMP ACCESS DOOR, OR RAMP, RIGHT AWAY.

Exhaust gas poisoning causes dizziness, headache, loss of muscle control, sleepiness, coma, and death. If anyone shows signs of exhaust gas poisoning, get ALL PERSONNEL out of the carrier. Make sure they have lots of fresh air. KEEP THEM WARM, CALM, AND INACTIVE. GET MEDICAL HELP. If anyone stops breathing, give artificial respiration. See FM 4-25.11 for first aid.

WARNING

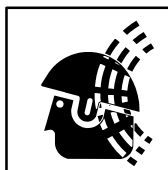

Noises from carrier or weapons can damage hearing of personnel in carrier. All personnel in carrier MUST WEAR DOUBLE HEARING PROTECTION when gun or carrier is operated. Hearing protection devices must be properly worn to provide effective protection.

If DOUBLE HEARING PROTECTION is not worn, the safe level of noise exposure will be exceeded in a short time. Hearing loss occurs gradually. Each noise exposure that exceeds the ear protection guidelines below will cause a temporary hearing loss. Over time, the loss in hearing will become permanent. Plan each day's operation, and be sure all crew and riders have the required ear protectors. Spare foam earplugs must be available.

WARNING SUMMARY (cont)

Definitions:

DH-132	The "tankers helmet," also called "CVC" helmet. Must be in good condition, with liner and earcups fitted tightly, and chin strap worn at all times.
Earplugs	Only standard issue earplugs are acceptable. All of the dismantled squad soldiers must be trained in how to use them. Since they may be removed and lost, spares must be carried.
Double Hearing Protection	Use of two hearing protection devices at the same time. For this carrier, use earplugs with the DH-132 helmet.

Ear Protection Guidelines:

Driver	Must wear DH-132 helmet at all times. Must wear DH-132 helmet plus earplugs for operations exceeding 14 miles (23 km) in 24 hours.
Squad Members	Must wear helmet and ear plugs at all times.
Use Of Radio With Earplugs	Wearing foam earplugs in addition to your DH-132 helmet can actually improve your ability to hear the radio in a high level noise area. DO NOT remove the earplugs to use the radio.

LIST OF WARNINGS IN WP PROCEDURES

This list includes all the critical WARNINGS in the WP procedures. Study these WARNINGS carefully. They can save your life and the lives of soldiers with whom you work.

WARNING



DEADLY CARGO. Personnel could be killed if ammunition or other cargo get into engine compartment. Do not operate the M548A1/M548A3 carrier carrying cargo without rear engine access panels and plywood protector installed.

WARNING

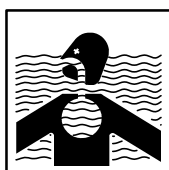

DO NOT SWIM CARRIER. M548A1 and M548A3 carriers can ford water up to 40 inches deep. Carrier will sink in water deeper than 40 inches, personal may be killed or injured and equipment damaged. These carriers do not swim. Do not try to enter water know to be deeper than 40 inches.

WARNING SUMMARY (cont)

WARNING



Rapid starts, sudden stops, and sharp turns can throw riders off carrier. Riders thrown from carrier can be killed or injured. Riders must sit inside carrier on seats that are provided. Riders must secure seat belts and wear CVC or regular helmet.

WARNING



Gas from batteries can explode and injure you. Do not have open flames, make sparks, or smoke near batteries. Battery acid can burn or blind you. Do not get acid on your skin or eyes.

WARNING



Battery posts and cables touched by metal objects can short circuit and burn you or injure you. Use caution when you work with tools or other metal objects. Do not wear jewelry when you work on electrical system.

WARNING



Touching your bare hands or tools to the starter terminals or electrical leads when accessing through the bottom access cover may cause death or serious injury. Do not touch any electrical leads or terminals on the starter because there is 24 volts with over 200 amps connected directly from the batteries.

WARNING SUMMARY (cont)

WARNING



Sparks from static electricity can cause a fire or explosion. Metal nozzle must touch metal in filler neck when fueling carrier or ground wire must be installed to carrier being refueled. Fuel can catch fire and burn you. Do not smoke. Wipe up spilled fuel. Starting engine right after a fire can restart fire. Do not move MASTER SWITCH to ON until cause of fire has been repaired or removed.

WARNING

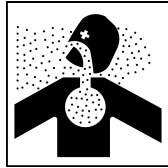

Exposure to CO₂ can cause dizziness, shortness of breath, muscular weakness. Stop engine before you discharge CO₂. If CO₂ is discharged, open hatch covers, or get all personnel out of carrier.

WARNING

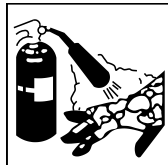

Discharging CO₂ gas can freeze your skin. Keep away from discharging gas.

WARNING



If fire occurs due to equipment malfunctions or damage, personnel can be killed or injured and equipment can be damaged. If fire extinguishers are empty, and there is a possibility of fire occurring, offload all ammunition.

WARNING SUMMARY (cont)

WARNING



Hot parts can burn you. Let hot parts cool before you start work.

WARNING



Hot oil and coolant can burn you. Let power unit cool before you start work.

WARNING



M548A3 carrier can pivot steer when transmission controller is in SL position and steering lock pin is not engaged. Personnel can be killed or injured. Make sure transmission controller is in SL and steering wheel is centered to engage steering lock pin (steering locked indicator light should be ON) unless carrier is to be steered.

WARNING



A fire can breakout any time. Personnel can be killed or injured. Equipment can be damaged. Make sure both fire extinguishers are ready to use before you operate carrier.

WARNING SUMMARY (cont)

WARNING



Operating carrier in reverse is dangerous due to limited vision and reversed steering. Always post ground guides before you back up.

WARNING

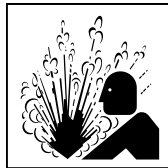

Hot radiator coolant can burn you. Use hand to remove cap only if cool to touch. Turn cap slowly to release pressure. Replace cap by pressing down and turning cap until tight.

WARNING



Unlatched cargo door can swing and injure personnel. Make sure door is latched closed or secured open.

WARNING



Do not attempt to change carrier forward of reverse movement by shifting until carrier comes to a complete stop. Above four miles per hour, if you attempt to shift into reverse (or forward), the M548A3 carrier will continue in the direction you are moving when you attempted to make the change. Failure to follow the above instructions could result in injury or death to personnel and destruction of equipment or property.

WARNING SUMMARY (cont)

WARNING

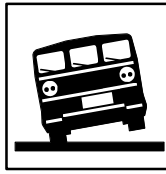

If you lose a track (break a track shoe or carrier throws a track), extreme caution must be exercised in maintaining control. Immediately release accelerator and let the carrier coast to a stop. Do not apply braking action, i.e. brake pedal, laterals, pivot or any type of steering controls. This causes the carrier to pull to the active or good track and could result in a rollover. If it is absolutely necessary, apply braking action only, and we stress only, if the carrier is approaching a ravine, a cliff, or if you perceive the outcome to be catastrophic, probably resulting in fatalities. When rollover is imminent, all crew members should immediately withdraw inside the carrier, tighten seat belts and hold onto a secure fixture, until the carrier comes to a complete stop.

WARNING



When a track carrier gets out of control and overturns, it is safer to stay in the carrier than to try to get out while the carrier is still moving. You may receive slight injuries from being thrown against metal parts; but if you try to leave the vehicle, it may roll over and crush you. Once the carrier stops moving, get out as fast as possible because spilled fuel and oil may catch on fire. The first thing the driver should do in such an emergency is shut off the engine and turn off the MASTER SWITCH to minimize the fire hazard.

WARNING

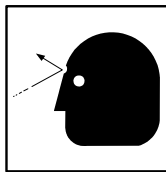

Hammering on drive pin punch of track pin may deflect particles of metal or dirt into soldier's eyes. To prevent eye damage, protection (goggles) is necessary.

WARNING SUMMARY (cont)

WARNING



Carrier operation during hot weather may result in heat stress to crew members. Crew members should limit their exposure based on TB Med 507.

WARNING



The operator should never leave the carrier without locking the steering levers (M548A1) or applying the parking brake (M548A3). Carrier could move, causing serious personal injury and damage to the carrier.

WARNING



All personnel must stand clear of carrier when an engine start is attempted. The operator should visually check to see that all areas of the carrier are clear of personnel before attempting to start engine. Failure to do so can result in serious personal injury.

WARNING



Do not grab steering wheel (M548A3) when entering or leaving cab. Carrier can pivot steer when engine is running, causing injury or death.

WARNING SUMMARY (cont)

WARNING



Do not place tools or other solid objects under the driver's seat or on the floor at the driver's feet. Keep the area clean. Such items can roll underneath the brake pedal (M548A3), preventing brake application, which could result in serious personal injury in case of accident.

WARNING

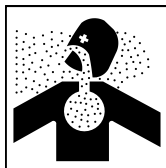

The protective mask and gas particulate filter unit (M548A3) will not protect against carbon monoxide. Carbon monoxide is deadly. Do not allow gas particulate unit to get wet. Once filters get wet they no longer protect against nuclear, biological or chemical agents. Under arctic conditions, danger of frostbite exists. Put on protective mask, but do not connect filtered air hose breakaway socket to protective mask canister unless carrier interior temperature is above 20°F (-7°C) or heater has warmed up the filtered air.

WARNING SUMMARY (cont)

WARNING



Use extreme caution **AT ALL TIMES** when handling DS2. DS2 is a combustible solution. Severe chemical burns can result if personnel fail to observe all safety precautions. DS2 can damage eyes and skin, and if inhaled, can cause illness. DS2 can damage the NBC protective overgarment. Long term contact with DS2 (about 24 hours) can damage the NBC protective gloves, hood, and overboots. To avoid injury:

Wear protective NBC clothing including mask, hood, and rubber gloves **AT ALL TIMES** when handling DS2 in a contaminated environment. If available, wear M2 Toxicological Agent Protective Apron. In extreme cold temperatures, wear rubber gloves **INSIDE** arctic mittens. Change mittens if they become soaked with DS2 since DS2 can damage rubber gloves.

DO NOT allow DS2 to spray on personnel.

DO NOT allow DS2 to spray on clothing.

DO NOT allow DS2 on hot exhaust, hot surfaces or open flames as it can cause fire.

DO NOT use DS2 to decontaminate personnel. It is harmful to the skin and eyes.

DO NOT inhale DS2 fumes, you may start coughing and become ill.

DO NOT use the M13 DAP if the container is damaged or leaking.

DO NOT use the DS2 filled, green painted container for training.

DS2 makes surfaces slippery; use caution to avoid falling.

Keep fluid container on the same level as operator is standing as it can tip over and cause injury.

M13 DAP filled with DS2 weights 54 lbs (24.5 kg). Be careful to avoid injury when lifting it 4 feet (1.2 m) or higher.

WARNING



Carrier may move and result in injury or death, or damage to carrier. Before hooking up a tow bar or disconnecting the drive shafts to the final drives, block the carrier with blocks so that it cannot move.

WARNING SUMMARY (cont)

WARNING



Wear gloves whenever you handle the winch wire rope (M548A1). Never let wire rope run through your hands. Rusty or broken wire can cause severe personal injury.

WARNING



Improper installation of pintle lock pin can allow trailer to disengage and cause extensive damage to the carrier and the towed load, and or injury to personnel. Bend the pin end as required.

WARNING

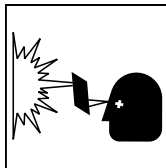

Do not look directly into infrared lights. You may damage your eyes.

WARNING SUMMARY (cont)

WARNING

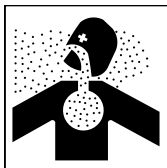

Chemical Agent Resistant Coating (CARC) paint contains isocyanate (HDI) which is highly irritating to skin and respiratory system. High concentrations of HDI can produce symptoms of itching and reddening of skin, a burning sensation in throat and nose, and watering of the eyes. In extreme concentrations, HDI can cause cough, shortness of breath, pain during respiration, increased sputum production, and chest tightness. The following precautions must be taken whenever using CARC paint:

ALWAYS use air line respirators when using CARC paint unless air sampling shows exposure to be below standards. Use chemical cartridge respirator if air sampling is below standards.

DO NOT let skin or eyes come in contact with CARC paint. Always wear protective equipment (gloves, ventilation mask, safety goggles, etc.).

DO NOT use CARC paint without adequate ventilation.

NEVER weld or cut CARC-coated materials.

DO NOT grind or sand painted equipment without high-efficiency air purifying respirators in use.

BE AWARE of CARC paint exposure symptoms; symptoms can occur a few days after initial exposure. Seek medical help immediately if symptoms are detected.

WARNING



Mixing of CARC paint must be done in a well-ventilated mixing room or spraying area away from open flame with personnel wearing eye protection. Paint is flammable and can cause injury or death to personnel.

WARNING



Protective equipment (gloves, goggles, ventilation mask) must be worn when using CARC paint. **DO NOT** leave any skin exposed. Contact with CARC paint can cause skin burns.

WARNING SUMMARY (cont)

WARNING



Carrier fire could cause injury or death and destroy equipment. Except in an emergency, do not operate the vehicle if either fire extinguisher has been discharged or will not work.

WARNING



Track shoe bushing failure can cause track assembly failure and loss of vehicle control. Soldiers can be killed or injured.

Do not use excessive force that could damage the track shoe bushing while driving in the track pin during assembly.

WARNING



Not having the correct track tension during inspection can cause you to not see defective track parts that could cause track failure and loss of vehicle control. Soldiers can be killed or injured.

Adjust track tension before inspecting track assembly and track shoes.

WARNING



Failure to perform track PMCS and not repair or report to maintenance per technical manual procedures can allow you to operate the vehicle with defective track parts that could cause track failure and loss of vehicle control. Soldiers can be killed or injured.

Never operate a vehicle without performing the BEFORE mission PMCS track tension adjustment and track inspection per PMCS procedures in the technical manual. Repair or report problems to maintenance per technical manual instructions as outlined in PMCS.

WARNING SUMMARY (cont)

WARNING



Sudden carrier movement can throw you out of seat. Wear seat belt while carrier is in motion. Do not use any seat with missing or inoperative seat belt.

WARNING

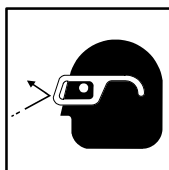

Always wear eye protection when using a hammer. Eye injury may result if metal chips contact eyes.

WARNING



Track shoe bushing failure due to improper angle of track during pin assembly can cause track assembly failure and loss of vehicle control. Soldiers can be killed or injured.

Make sure track is assembled with the right amount of angle or lift as shown below. Properly assembled track will lay flat. Incorrectly assembled track will bulge upward.

FIRST AID

For first aid information, see FM-25.11.

CHANGE
NO. 1

HEADQUARTERS
DEPARTMENT OF THE ARMY
WASHINGTON, D.C., 26 AUGUST 2005

TECHNICAL MANUAL
OPERATOR'S MANUAL

FOR

CARRIER, CARGO TRACKED, 6-TON
M548A1
2350-01-096-9356 (EIC AEU)

CARRIER, CARGO TRACKED, 6-TON
M548A3
2350-01-369-6081 (EIC AE9)

CURRENT AS OF 5 JANUARY 2004

DISTRIBUTION STATEMENT A – Approved for public release; distribution is unlimited.

TM 9-2350-247-10, 30 June 2001 is updated as follows:

1. File this change sheet in front of the publication for reference purposes.
2. New or updated text is indicated by a vertical bar in the outer margin of the page.
3. Revised illustrations are indicated by a miniature pointing hand adjacent to the updated area.
4. Remove old pages/Work Packages and insert new pages/Work Packages as indicated below.

Remove Pages/Work Packages

a – b
g – h
m/n blank
A/B blank
i – vi
WP 0001 00 – 0002 00
WP 0039 00
WP 0046 00
WP 0053 00
WP 0056 00
Chapter 4 WP Index
WP 0057 00 – 0058 00
None
WP 0059 00
None
WP 0060 00
None
None
WP 0061 00
None
WP 0062 00

Insert Pages/Work Packages

a – b
g – h
m – n
A/B blank
i – vi
WP 0001 00 – 0002 00
WP 0039 00
WP 0046 00
WP 0053 00
WP 0056 00
Chapter 4 WP Index
WP 0057 00 – 0058 00
WP 0058 01
WP 0059 00
WP 0059 01
WP 0060 00
WP 0060 01
WP 0060 02
WP 0061 00
WP 0061 01
WP 0062 00

Remove Pages/Work Packages

WP 0079 00 – 0083 00
Index-1 – Index-9/10 Blank
None
DA Form 2028 (3)
Metric Chart/Back Cover
Front Cover

Insert Pages/Work Packages

WP 0079 00 – 0083 00
Index-1 – Index-11/12 Blank
Sample DA Form 2028
DA Form 2028 (3)
Metric Chart/Back Cover
Front Cover

By Order of the Secretary of the Army:

Official:

SANDRA R. RILEY
*Administrative Assistant to the
Secretary of the Army*
0519901

PETER J. SCHOOMAKER
*General, United States Army
Chief of Staff*

DISTRIBUTION:

To be distributed in accordance with the initial distribution number (IDN) 370824 requirements for TM 9-2350-247-10.

INSERT LATEST UPDATED PAGES/WORK PACKAGES. DESTROY SUPERSEDED DATA.

LIST OF EFFECTIVE PAGES/WORK PACKAGES

Note: Updates to all portions of this TM are indicated by a vertical bar in the outer margin of the page.

Dates of issue for original and updated pages/work packages are:

Original 0 (30 June 2001)
Change 1 (26 August 2005)

TOTAL NUMBER OF PAGES FOR FRONT AND REAR MATTER IS 52 AND TOTAL NUMBER OF WORK PACKAGES IS 89 CONSISTING OF THE FOLLOWING:

Page/WP No.	*Change No.	Page/WP No.	*Change No.	Page/WP No.	*Change No.
Cover	1	WP 0084 00	0		
Transmittal/Authentication	1	Index-1 – Index-11/12 blank	1		
a	1	Authentication Page	0		
b – g	0	DA 2028 Sample/Reverse	1		
h	1	DA 2028/Reverse (3)	1		
i – l	0	Metric Chart	1		
m – n	1	Back Cover	1		
A/B blank	1				
i – v	1				
vi	0				
Chapter 1 WP Index	0				
WP 0001 00 – 0002 00	1				
WP 0003 00	0				
Chapter 2 WP Index	0				
WP 0004 00 – 0038 00	0				
WP 0039 00	1				
WP 0040 00 – 0045 00	0				
WP 0046 00	1				
WP 0047 00 – 0052 00	0				
WP 0053 00	1				
Chapter 3 WP Index	0				
WP 0054 00 – 0055 00	0				
WP 0056 00	1				
Chapter 4 WP Index	1				
WP 0057 00 – 0058 00	1				
WP 0058 01 (Added)	1				
WP 0059 00	1				
WP 0059 01 (Added)	1				
WP 0060 00	1				
WP 0060 01 (Added)	1				
WP 0060 02 (Added)	1				
WP 0061 00	1				
WP 0061 01 (Added)	1				
WP 0062 00	1				
WP 0063 00 – 0078 00	0				
Chapter 5 WP Index	0				
WP 0079 00	1				
Chapter 6 WP Index	0				
WP 0080 00 – 0083 00	1				

*Zero in this column indicates an original page.

HEADQUARTERS
DEPARTMENT OF THE ARMY
WASHINGTON, D.C., 30 JUNE 2001

**TECHNICAL MANUAL
OPERATOR'S MANUAL**

**CARRIER, CARGO TRACKED, 6-TON M548A1
NSN 2350-01-096-9356
(EIC AEU)**

**M548A3
NSN 2350-01-369-6081
(EIC AE9)**

REPORTING ERRORS AND RECOMMENDING IMPROVEMENTS

You can help improve this publication. If you find any mistakes or if you know of a way to improve the procedures, please let us know. Submit your DA Form 2028 (Recommended Changes to Equipment Technical Publications) through the Internet, on the Army Electronic Product Support (AEPS) website. The Internet address is <http://aeps.ria.army.mil>. If you need a password, scroll down and click on "ACCESS REQUEST FORM." The DA Form 2028 is located in the ONLINE FORMS PROCESSING section of the AEPS. Fill out the form and click on SUBMIT. Using this form on the AEPS will enable us to respond quicker to your comments and better manage the DA Form 2028 program. You may also mail, fax, or email your letter or DA Form 2028 directly to: Technical Publication Information Office, TACOM-RI, 1 Rock Island, IL 61299-7630. The email address is TACOM-TECH-PUBS@ria.army.mil. The fax number is DSN 793-0726 or Commercial (309) 782-0726.

CURRENT AS OF 5 JANUARY 2004

SUPERSEDURE NOTICE — This manual supersedes TM 9-2350-247-10 dated August 1994, including all changes.

DISTRIBUTION STATEMENT A — Approved for public release; distribution is unlimited.

TABLE OF CONTENTS

WP Sequence No.

WARNING SUMMARY

HOW TO USE THIS MANUAL

CHAPTER 1 — OPERATOR INTRODUCTORY INFORMATION WITH THEORY
OF OPERATION

GENERAL INFORMATION.....	0001 00
EQUIPMENT DESCRIPTION.....	0002 00
THEORY OF OPERATION.....	0003 00

TABLE OF CONTENTS (cont)

WP Sequence No.

CHAPTER 2 — OPERATOR INSTRUCTIONS

DESCRIPTION AND USE OF DRIVER’S CONTROLS AND INSTRUMENTS.....	0004 00
OPEN/CLOSE CARGO COMPARTMENT DOOR AND TAILGATE.....	0005 00
REMOVE/INSTALL TOP ACCESS COVER AND GRILLES (M548A3).....	0006 00
REMOVE/INSTALL CARGO COMPARTMENT FLOOR PLATES.....	0007 00
OPEN/CLOSE CARGO AREA (SECONDARY) VEHICLE COMPARTMENT HEATER KIT.....	0008 00
OPEN/CLOSE CAB DOORS AND WINDOWS.....	0009 00
ADJUST DRIVER’S SEAT.....	0010 00
RAISE/LOWER CAB PERSONNEL SEATS.....	0011 00
SET/RELEASE PARKING BRAKE (M548A3).....	0012 00
START ENGINE (M548A1).....	0013 00
START ENGINE (M548A3).....	0014 00
START ENGINE WITH EXTERNAL POWER.....	0015 00
START/DRIVE CARRIER WITH NO ELECTRICAL POWER OR WITH FAULTY TRANSMISSION SHIFT CONTROLLER (M548A3).....	0016 00
LOAD CARGO.....	0017 00
CHECK INSTRUMENT PANEL (M548A1).....	0018 00
CHECK INSTRUMENT PANEL (M548A3).....	0019 00
DRIVE CARRIER (M548A1).....	0020 00
DRIVE CARRIER (M548A3).....	0021 00
OPERATE TURN SIGNAL KIT.....	0022 00
STOP ENGINE (M548A1).....	0023 00
STOP ENGINE (M548A3).....	0024 00
FUEL CARRIER.....	0025 00
INSTALL/REMOVE AIR INTAKE AND EXHAUST GRILLE COVERS (M548A1).....	0026 00
INSTALL/REMOVE AIR INTAKE AND EXHAUST GRILLE COVERS (M548A3).....	0027 00
OPERATE AIR BRAKE KIT (M548A1).....	0028 00
OPERATE MATERIAL HANDLING KIT.....	0029 00
OPERATE WINCH (M548A1).....	0030 00
OPERATE VEHICLE COMPARTMENT AND CARGO HEATER.....	0031 00
OPERATE CARRIER LIGHTS.....	0032 00
OPERATE FIXED FIRE EXTINGUISHER SYSTEM.....	0033 00
OPERATE PORTABLE FIRE EXTINGUISHER.....	0034 00
MACHINE GUN MOUNTING KITS.....	0035 00
REMOVE/INSTALL POWER PLANT REAR ACCESS COVERS/DOOR AND PANEL.....	0036 00
RAISE/LOWER COMPARTMENT ACCESS DOOR (M548A3).....	0037 00
BLOCK/UNBLOCK CARRIER TRACKS.....	0038 00
OPERATE CARRIER IN EXTREME COLD: BELOW -25°F (-31°C).....	0039 00
OPERATE ENGINE COOLANT HEATER KIT (M548A1).....	0040 00

TABLE OF CONTENTS (cont)

WP Sequence No.

OPERATE ENGINE COOLANT HEATER KIT (M548A3).....	0041 00
PERFORM PRE-FORDING OPERATIONS.....	0042 00
FORD WATER UP TO 40 INCHES DEEP.....	0043 00
PERFORM POST-FORDING OPERATION.....	0044 00
OPERATE CARRIER OVER ROUGH TERRAIN.....	0045 00
OPERATE CARRIER IN EXTREME HEAT, HUMIDITY, OR SALTY CONDITIONS.....	0046 00
BYPASS DEFECTIVE TRANSMISSION CONTROLLER (M548A3).....	0047 00
CONNECT TOWED LOAD.....	0048 00
TOWING DISABLED CARRIER (M548A1).....	0049 00
TOWING DISABLED CARRIER (M548A3).....	0050 00
TOW START DISABLED CARRIER (M548A1).....	0051 00
TOW START DISABLED CARRIER (M548A3).....	0052 00
OPERATE NBC AIR FILTER SYSTEM (M548A3).....	0053 00
 CHAPTER 3 — OPERATOR TROUBLESHOOTING PROCEDURES	
INTRODUCTION TROUBLESHOOTING.....	0054 00
TROUBLESHOOTING SYMPTOM INDEX.....	0055 00
TROUBLESHOOTING TABLE.....	0056 00
 CHAPTER 4 — OPERATOR MAINTENANCE INSTRUCTIONS FOR MAINTENANCE	
PREVENTIVE MAINTENANCE CHECKS AND SERVICES.....	0057 00
INSPECT/ADJUST T130 TRACK TENSION.....	0058 00
ADJUST T150 TRACK TENSION.....	0058 01
BREAK/JOIN T130 TRACK.....	0059 00
BREAK/JOIN T150 TRACK.....	0059 01
REMOVE/INSTALL T130 TRACK SHOE.....	0060 00
REMOVE/INSTALL T150 TRACK SHOE.....	0060 01
ASSEMBLE T130 TRACK SHOE SECTIONS OFF VEHICLE.....	0060 02
REMOVE/INSTALL T130 TRACK PAD.....	0061 00
TRACK SHOE WEAR LIMITS.....	0061 01
INSPECT T130 SPROCKET WEAR.....	0062 00
MAINTENANCE OF AIR CLEANER ELEMENT (M548A1).....	0063 00
REMOVE/INSTALL AIR CLEANER ELEMENT DOOR (M548A3).....	0064 00
CHECK/FILL COOLING SYSTEM (M548A1).....	0065 00
CHECK/FILL COOLING SYSTEM (M548A3).....	0066 00
CHECK DRIVE BELTS TENSION (M548A1).....	0067 00
CHECK DRIVE BELTS TENSION (M548A3).....	0068 00
DRAIN FUEL FILTERS AND AIR SEPARATOR TANK.....	0069 00
MAINTENANCE OF BATTERIES.....	0070 00
MAINTENANCE OF CARGO COVER.....	0071 00
MAINTENANCE OF CAB COVER AND WINDOWS.....	0072 00

TABLE OF CONTENTS (cont)

WP Sequence No.

SERVICE BILGE PUMP.....	0073 00
MAINTENANCE OF MACHINE GUN RING MOUNT ASSEMBLY (M66).....	0074 00
MAINTENANCE OF AIR BRAKE KIT (M548A1).....	0075 00
REMOVE/INSTALL HULL BOTTOM ACCESS COVER AND DRAIN COVER.....	0076 00
RAISE/LOWER CAB CENTER FLOOR PLATES.....	0077 00
REMOVE/INSTALL BULKHEAD PROTECTOR.....	0078 00
CHAPTER 5 — OPERATOR MAINTENANCE INSTRUCTIONS FOR AUXILIARY EQUIPMENT	
CLASSIFICATION AND IDENTIFICATION.....	0079 00
CHAPTER 6 — OPERATOR SUPPORTING INFORMATION	
REFERENCES.....	0080 00
COMPONENTS OF END ITEM AND BASIC ISSUE ITEMS.....	0081 00
ADDITIONAL AUTHORIZATION LIST (AAL).....	0082 00
EXPENDABLE/DURABLE SUPPLIES AND MATERIALS LIST.....	0083 00
STOWAGE GUIDE.....	0084 00

HOW TO USE THIS MANUAL

HOW TO USE THIS MANUAL

This manual tells you how to use the M548A1 and M548A3 6-ton cargo carriers.

Before starting a task or procedure, read HOW TO USE THIS MANUAL and DESCRIPTION AND USE OF OPERATOR'S CONTROLS AND INSTRUMENTS (WP 0004 00).

WHAT'S IN THE MANUAL — FRONT TO BACK

SUMMARY OF WARNINGS AND FIRST AID lists the Warnings and first aid information in this manual. The Warnings cover hazards that could kill or injure personnel. Shorter versions of these warnings may appear in the task procedure.

TABLE OF CONTENTS lists the Work Packages for each chapter.

CHAPTER 1 covers General Information. It gives a brief description of the major parts and features of the carrier.

CHAPTER 2 covers descriptions and functions of all controls and indicators.

CHAPTER 3 covers Troubleshooting Work Packages.

CHAPTER 4 covers Preventive Maintenance Checks and Services, including Lubrication Instructions and Maintenance Work Packages.

CHAPTER 5 provides supporting information for the Technical Manual. It includes the following Work Packages:

The REFERENCES Work Package (WP 0080 00) lists references to be used by personnel in operating and maintaining the carriers. These references include technical manuals and other publications.

The COEI/BII Work Package (WP 0081 00) lists Components of End Item and Basic Issue Items. Components of End Item are those items which are assembled and become a permanent part of the carrier. Basic Issue Items are items needed to put the carrier in operation, operate it, and do emergency repairs.

The Additional Authorization List Work Package lists additional items required to support the carrier during operation (WP 0082 00).

The EXPENDABLE/DURABLE SUPPLIES AND MATERIALS Work Package (WP 0083 00) lists expendable supplies and materials that will be needed to operate and maintain the carrier.

The STOWAGE GUIDE Work Package (WP 0084 00) is a stowage guide for all removable equipment carried in and on the carriers. This work package includes a guide to identification (ID) plates on the carriers.

The INDEX is an alphabetical listing of all the major controls, procedures, indicators, systems, and subsystems covered in this manual. Each entry is cross-referenced to the Work Package number and page number.

DA FORM 2028 is used to report errors and to recommend improvements for procedures in this manual. Three blank DA Forms 2028 are in the back of this manual. A sample is provided to show you how to fill out the DA Form 2028.

The back cover includes a METRIC CONVERSION CHART that can be used to convert U.S. customary measurements to their metric equivalents. Measurements in this manual are given in U.S. customary units with metric units in parentheses.

HOW TO USE THE WORK PACKAGES

How to find the Work Package you need

Pick a key word from the carrier part or system to be used. Look in the INDEX for this key word or the name of the action you will perform. Turn to the Work Package and page indicated.

The INDEX lists each Work Package under one or more headings. For example, the Work Package titled ADJUST DRIVER'S SEAT could be found under the two headings, "Driver," and "Seat."

HOW TO USE THIS MANUAL (cont)

How to read the Work Package

Work Packages provide either descriptive/supporting information or detailed procedures for operating and maintaining the equipment. The Work Packages in Chapter 1 include General Information only. Chapter 2 includes descriptive information on Controls and Indicators, and Operating Procedures. Chapter 3 includes Troubleshooting Procedures. Chapter 4 covers PMCS, including Lubrication Instructions and Maintenance Procedures. Chapter 5 includes Supporting Information.

Pay attention to all Warnings, Cautions, and Notes. These can appear in all types of procedures. They help you avoid harm to yourself, other personnel, and equipment. They also tell you things you should know about the procedure.

Before you start a procedure, get all the tools, supplies, and personnel you need to do the procedure. These items will be listed in the INITIAL SETUP of the Work Package.

Start with step 1 and do each step in the order given. Numbered primary steps tell you WHAT to do. Alpha substeps tell you HOW to do it.

Look at the illustrations. Locators show you where the equipment and parts are located in the carrier. Closeup illustrations show the details you need to do the procedure.

Operator and Maintenance Instructions Work Packages

Operation Work Packages tell you how to operate the carrier and its equipment. Each operation Work Package details steps which need to be performed to complete the task.

Maintenance Work Packages help the crew to keep the carrier in operating condition. Crew members are authorized to remove, clean, inspect, lubricate, and install certain parts on the carrier.

Operation and maintenance Work Packages are written in the same format.

Read the INITIAL SETUP section carefully before you start a task. Get the tools and supplies listed and the personnel needed to perform the task. Be sure that the equipment is in the condition called out under the Equipment Condition step.

Read all of the Work Package before starting. Follow the steps in the order. END OF TASK indicates the end of the procedure.

Preventive Maintenance Checks and Services (PMCS), Including Lubrication Instructions Work Package

Preventive Maintenance Checks and Services (PMCS) must be done to keep your carrier operating correctly. Do the PMCS procedures both daily and weekly as required. There are four types of PMCS:

The BEFORE (B) PMCS must be done before you operate the carrier.

The DURING (D) PMCS must be done when you operate the carrier. Monitor the carrier systems as you perform your mission. Perform DURING (D) PMCS on a system only when the system is required to complete your mission.

The AFTER (A) PMCS must be done after completing your mission.

The WEEKLY (W) PMCS must be done weekly.

Notify unit maintenance if anything seems wrong with the carrier or its systems and you cannot fix it yourself. Loose bolts or damaged welds are common things to watch for in every area. When checking hoses and fluid lines, look for wear, leaks, loose clamps, and loose fittings.

Troubleshooting Work Packages

Troubleshooting Work Packages help solve common problems and malfunctions. The Troubleshooting Symptom Index (WP 0055 00) lists malfunctions common to your carrier and the Index will guide you to the Troubleshooting Table.

DEFINITION OF WORK PACKAGE TERMS

Warnings, Cautions, And Notes

Read all Warnings, Cautions, and Notes in the Work Package. Warning, Cautions, and Notes are placed just before the step for which they apply. Ignoring a Warning can cause death or injury to you or other personnel. Ignoring a Caution can cause damage to equipment. Notes have facts to make the step and Work Package easier.

HOW TO USE THIS MANUAL (cont)

WARNINGS call attention to the things that could kill or injure personnel. Warnings are also listed at the front of the manual.

WARNING



Hot oil and coolant can burn you. Let power unit cool before you start work.

A sample WARNING is shown above.

CAUTIONS call attention to actions or material that could damage equipment.

CAUTION

Improper cable removal can cause a short circuit. remove negative cable before you remove positive cable.

A sample CAUTION is shown above.

NOTES contain information that makes the step and Work Package easier to do.

NOTE

When quick release pin is removed, mirror control knob will spring back into locked position.

A sample NOTE is shown above.

HELPER

Helpers are needed for Work Packages that require more than one person such as lifting heavy objects or acting as an observer. If a helper is needed to perform a procedure, the INITIAL SETUP will list "Helper" under the PERSONNEL REQUIRED heading.

If helper assists with a step, the step will include: "Have helper assist".

If a helper performs the action alone, the step will start with "(H)".

Locational Terms

The terms FRONT, REAR, LEFT, and RIGHT are used to indicate where items are located on the carrier. Think of these locations as if you were standing at the rear of the carrier facing the inside of the carrier.

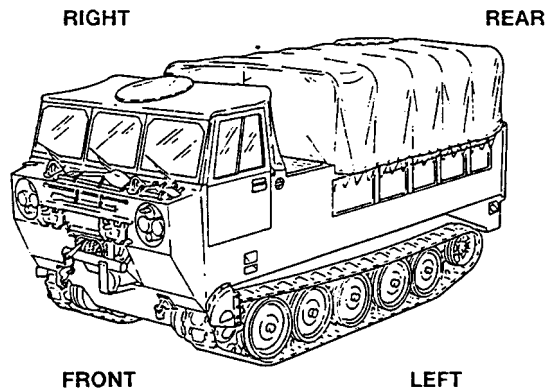

CHAPTER 1

OPERATOR INTRODUCTORY INFORMATION WITH THEORY OF OPERATION

WORK PACKAGE INDEX

<u>Title</u>	<u>Sequence No.</u>
GENERAL INFORMATION.....	.0001 00
EQUIPMENT DESCRIPTION.....	.0002 00
THEORY OF OPERATION.....	.0003 00

GENERAL INFORMATION

0001 00

SCOPE

M548A1 □ Cargo Carrier, 6-Ton

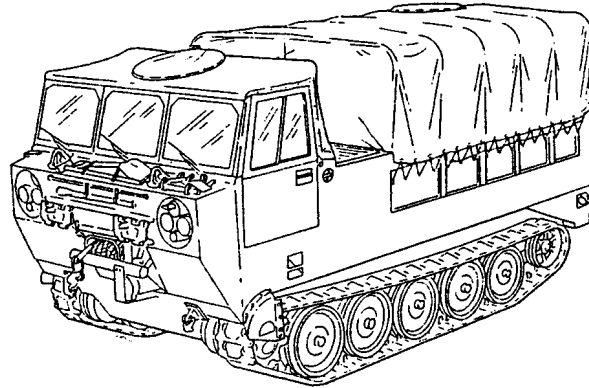

LEFT FRONT VIEW

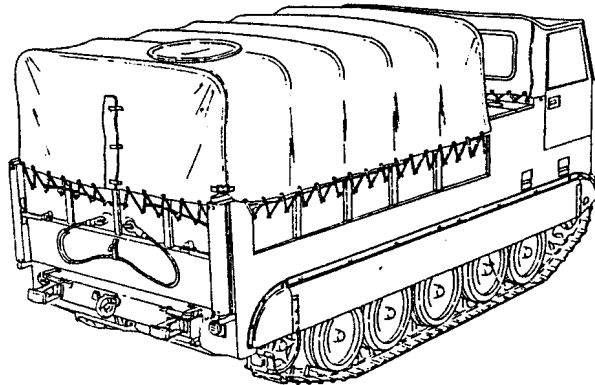

RIGHT REAR VIEW

NOTE

Components that are peculiar to the M548A1 and M548A3 carriers are marked within each specific paragraph and figure title throughout this manual. All components and systems not marked are common to the M548A1 and M548A3.

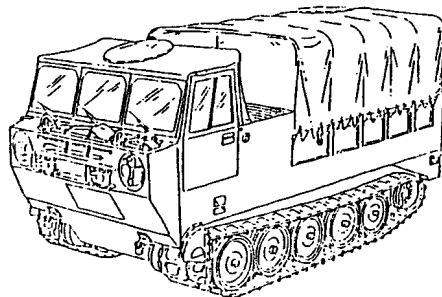
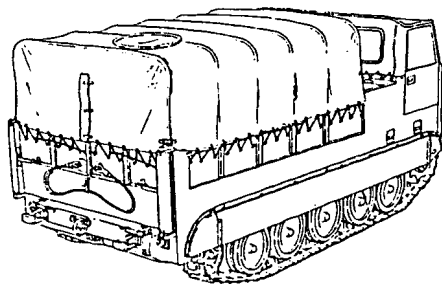
**M548A3 LEFT FRONT VIEW****M548A3 RIGHT REAR VIEW**

This manual is for your use in operating and maintaining the M548A1 and M548A3 6-Ton Tracked Cargo Carriers. It contains information you need to operate the carriers under various conditions. It shows you how to take care of your carrier. There are major differences in the driver's operation of the M548A3 versus the M548A1. Make sure you read all the information supplied in the manual for driver's controls and operation for the type of carrier you are using.

MAINTENANCE FORMS, RECORDS, AND REPORTS

Department of the Army forms and procedures used for equipment maintenance will be those prescribed by DA Pamphlet 738-750, The Army Maintenance Management System (TAMMS).

REPORTING EQUIPMENT IMPROVEMENT RECOMMENDATIONS (EIR)

EIRs can and must be submitted by anyone who is aware of an unsatisfactory condition with the equipment design or use. If it is not necessary to show design or list a better way to perform a procedure, just simply tell why the design is unfavorable or why a procedure is difficult. EIRs may be submitted on SF 368 (Quality Deficiency Report). Mail directly to Commander, U.S. Army Tank-Automotive and Armaments Command, Attn: AMSTA-TR-QCD, Warren, MI, 48397-5000.

DESTRUCTION OF ARMY MATERIEL TO PREVENT ENEMY USE

See the following technical manuals for information on destruction of Army materiel:

TM 750-244-2 Procedures for Destruction of Electronic Materiel to Prevent Enemy Use.

TM 43-0002-33 Destruction of Conventional Ammunition and Improved Conventional Munitions (ICM) to Prevent Enemy Use.

TM 750-244-6 Procedures for Destruction of Tank Automotive Equipment to Prevent Enemy Use.

TM 750-244-7 Procedures for Destruction of Equipment in Federal Supply Classifications 1000, 1005, 1010, 1015, 1020, 1025, 1030, 1055, 1090, and 1095 to Prevent Enemy Use.

NOMENCLATURE CROSS-REFERENCE

This listing includes nomenclature cross references used in this manual.

CVC Helmet	DH 132 Helmet
Dipstick	Liquid Measure Gauge Rod
M25A1 Mask	Mask, Chemical-Biological: Tank, M25A1
Track and Sprocket	Track Tension, Track Bushing and Sprocket
Gauge	Wear Gauge
Transmission	Transmission, Cross Drive
Slave Cable	Adapter Cable Assembly

LIST OF ABBREVIATIONS / ACRONYMS

Many abbreviations are used in this manual. They are listed below. Learn what each one means. It will make your job easier.

A	After
B	Before
BATT	Battery
BO	Blackout
BRT	Bright
CB	Circuit Breaker or Common Battery
COEIL	Components of End Items List
CVC	Combat Vehicle Communications
D	During
ENG	Engine
FOV	Field-of-view
GEN	Generator
HI-TEMP	High Temperature
Intercom	Intercommunication
IR	Infrared
LO	Lubrication Order
NBC	Nuclear, Biological and Chemical
N2	Nitrogen gas

GENERAL INFORMATION — Continued

0001 00

OVE	On Vehicle Equipment
PMCS	Preventive Maintenance Checks and Services
PRESS	Pressure
TEMP	Temperature
TRANS	Transmission
Vent	Ventilation
W	Weekly

SAFETY, CARE, AND HANDLING

Read warnings in the Warning summary in the front of the manual.

EQUIPMENT DESCRIPTION

0002 00

CARRIER

WARNING

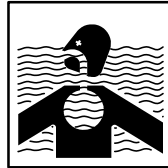

Do not swim carrier. Injury to personnel and equipment may occur. The M548A1 and M548A3 carriers can ford water up to 40 inches (107 cm) deep. However, these carriers do not swim. Do not try to enter water known to be deeper than 40 inches (107 cm).

The M548A1 and M548A3 6-Ton Tracked Cargo Carriers are lightweight and unarmored. They are full-tracked cargo carriers for use as cargo and ammunition support carriers. These carriers can cross small streams and cross rough ground, and move over roads and highways. They can be air-transported. A full width cab provides enclosed seating for the driver and three passengers. The following pages provide: information on various kits and equipment, a series of illustrations showing the Location and Description of Major Components, and a detailed list of the Differences Between Models. See the table of Equipment Data at the end of this section for a list of important carrier data.

LOCATIONAL TERMS

The terms right, left, front, or rear are used in this manual to describe areas and parts of the carrier and their location relative to each other. The terms are used the same way you would use them if you stood at the cargo door end of the carrier and looked toward the cab.

MATERIEL USED WITH CARRIER

Various kits and equipment can be applied to the M548A1 and M548A3 carriers to prepare them for particular missions or operating conditions. The individual kits are listed below. If you have one or more of these kits, be sure to check your Preventive Maintenance Checks and Services (WP 0057 00).

MATERIAL HANDLING KIT

Required for ammunition support. The kit includes a hand-operated chain hoist on an overhead beam, a plywood protector for the power plant compartment bulkhead, and seats and seat belts in the cargo compartment for four ammunition handlers. The kit also provides stowage for six rifles on the cargo compartment door. See Material Handling Kit illustration under Location and Description of Major Components. See Equipment Data table for details.

AIR BRAKE KIT (M548A1)

Required when the carrier is used as a prime mover for towed equipment that has air brakes. The kit includes a compressor and air tank, air hoses, a pressure gauge, and a treadle valve. See Air Brake Kit illustration under Location and Description of Major Components. See Equipment Data table for details. The M548A3 carrier is unable to use this kit because of a different power train.

TURN SIGNAL KIT

Required in some areas when the carrier is to be driven on roads or highways. The kit adds front signal lights and brackets, a control unit, a flasher and reflectors, and changes the tail lights. See Turn Signal Kit illustration under Location and Description of Major Components.

VEHICLE COMPARTMENT HEATER KIT

Required to provide heat for personnel and windshield defrosting in cold weather. The kit includes a heater, fuel pump, fuel filter, control box, ducts, and valves. Your carrier could be equipped with one of three cab vehicle compartment heater kits. Kit one takes in outside air through a duct in the power plant compartment, has a tubular heat manifold which crosses the width of the cab below the windshield, and provides a duct that supplies heated air to the cargo compartment. Kit two takes in cab air through a duct behind the driver's seat and has two defroster ducts, a separate cab heat distributor and regulator valve, and a separate duct to heat the driver's footwell. Kit three is identical to kit two except that there is no regulator valve, and two fans with individual ON-OFF switches circulate cab air to the defroster ducts. See Vehicle Compartment Heater Kit illustration under Location and Description of Major Components. See Equipment Data table for details. On the M548A3, the vehicle compartment heater is an installation, not a kit; see Vehicle Compartment Heater and Defrosters illustration under Location and Description of Major Components. It is located where the winch used to be. The front access cover should always be secured properly to avoid excess water from damaging the heater and possibly getting into the crew compartment. The vehicle compartment heater takes in fresh air through ducts under the instrument panel.

CARGO AREA (PRIMARY) VEHICLE COMPARTMENT HEATER (M548A1)

Required to provide heat for personnel seated in the cargo compartment in cold weather. (Material Handling Kit provides personnel seats.) The kit includes a heater, fuel pump, control box, fuel line, wiring harness, heat diffuser, and an exhaust pipe with guards to prevent injury to personnel or damage to cargo compartment cover. See Cargo Area (Primary) Vehicle Compartment Heater Kit illustration under Location and Description of Major Components. See Equipment Data table for details.

ENGINE COOLANT HEATER KIT

Required to permit carrier operation below -25°F (-31°C). The kit includes a heater, fuel pump, control box, coolant pump, heat exchanger plate (for batteries), and coolant lines and valves. See Cargo Area (Primary) Vehicle Compartment Heater Kit (M548A1), or Engine Coolant Heater Kit (M548A3) illustration under Location and Description of Major Components. See Equipment Data table for details.

VEHICLE COMPARTMENT (SECONDARY) HEATER KIT

Required to supplement the vehicle compartment heater kit for operation below -25°F (-31°C). The kit replaces the fabric cab cover with an insulated fiberglass cover, and adds thermal side windows, cloth seat covers, and foam insulation sheets to the cab. See Vehicle Compartment (Secondary) Heater Kit illustration under Location and Description of Major Components. See Equipment Data table for details.

CARGO AREA (SECONDARY) VEHICLE COMPARTMENT HEATER KIT

Required to supplement the cargo area (primary) personnel heater kit for operation below -25°F (-31°C). The kit replaces the fabric cargo compartment cover with an insulated fabric cover, adds plywood floor covers, cloth seat covers, and foam cargo door insulation panels. See Cargo Area (Secondary) Vehicle Compartment Heater Kit illustration under Location and Description of Major Components. See Equipment Data table for details.

MACHINE GUN MOUNTING KIT (M66 MOUNT)

Used to mount a cal .50 machine gun M2 or a 7.62 mm machine gun M60 over the carrier cab. The kit includes a machine gun mount M66, brackets, cartridge case deflector, and four supports. Rear supports have brackets for stowing the machine gun tripod M3. When issued for use only with the 7.62 mm machine gun M60, deflector and tripod brackets may be omitted. When this kit is installed, front carrier lifting eyes are removed and stowed under the cargo compartment floor plates. See Machine Gun Mounting Kit illustration under Location and Description of Major Components. See Equipment Data table for details.

CAL .50 MACHINE GUN MOUNTING KIT (M49A1 MOUNT)

Used to permit mounting a cal .50 machine gun M2 over the carrier cab. The kit is similar to the kit above, except that it uses a ring mount M49A1 in place of the mount M66. This kit cannot be used to mount a 7.62 mm machine gun M60. See Cal .50 Machine Gun Mounting Kit (M49A1 Mount) illustration under Location and Description of Major Components. See Equipment Data table for details.

7.62 MM MACHINE GUN MOUNTING KIT

Used to mount a 7.62 mm machine gun M60 over the carrier cab. The kit is similar to the cal .50 machine gun mounting kit, except that the pintle and cradle of the M49A1 mount are replaced by a 7.62 mm pintle, platform assembly, and cradle. The kit does not include a cartridge case deflector or tripod stowage brackets. See 7.62 mm Machine Gun Mounting Kit illustration under Location and Description of Major Components. See Equipment Data table for details.

CAL .50 MACHINE GUN KIT

May be authorized to increase the defensive capability of the carrier. A suitable machine gun mounting kit must be installed on the carrier. See Cal .50 Machine Gun M2 illustration. A tripod mount M3 may be issued with the machine gun and stowed on the machine gun mounting kit when ground-emplacing the machine gun is desired. See Machine Gun Mount M3 illustration under Location and Description of Major Components to see the tripod mount.

7.62 MM MACHINE GUN M60

May be authorized to increase the defensive capability of the carrier. A suitable machine gun mounting kit must be installed on the carrier. See Cal 7.62 mm Machine Gun M60 illustration under Location and Description of Major Components to see the 7.62 mm machine gun.

COOLING SYSTEM

The vent fan draws air in through the radiator, circulates it around the power plant, and expels it through the exhaust grille above the vent fan. The vent fan is belt-driven from the engine crankshaft. The auxiliary radiator tank, located on the transverse beam, provides space for the separation of air and liquid coolant. See Cooling System illustration under Location and Description of Major Components.

NUCLEAR, BIOLOGICAL, AND CHEMICAL (NBC) SYSTEM (M548A3)

The NBC air filter system consists of one M1A1-19 precleaner and particulate filter assembly, two M-18 gas canisters, and hoses and connectors for each crew station. The purpose of this system is to provide clean, filtered, pressurized air free of toxic agents to the M42 NBC mask at each crew station. The unit is controlled by the NBC switch on the master control panel.

The M1A1-19 precleaner assembly and particulate filter assembly contains the precleaner and a particulate filter. The precleaner is mounted on the assembly housing and consists of an electrically driven fan and dual dust separators. The fan draws air into the assembly housing from the carrier interior through slotted openings in the center section of the assembly housing. There is a spring clip attached to the outer surface of the assembly housing. The spring clip is used to cover the slotted openings in the center section of the assembly housing when the unit is not in use.

The fan forces the air into the dust separators which remove heavy particles from the air. The air then passes to the M19 particulate filter mounted in the assembly housing. The M19 particulate filter is a throw-away filter made of pleated filter material and paper separators encased in a metal container. The M19 particulate filter removes fine dust and aerosols from the air. The air then goes out of the housing assembly and is ducted to two M18 gas filter canisters through two air hoses. Each M18 gas filter is made of activated charcoal encased in a metal canister. The M18 gas filters remove toxic agents from the air. The air is then ducted to the orifice connector assemblies at each crew station by way of air hoses and adapters.

The orifice connector assembly is used to simulate the resistance of a protective mask when filtered air is being supplied to fewer than the allotted crew members. The filtered air hoses remain connected to the orifice connector assembly when the gas particulate unit is not in use. The system provides each crew station with clean, filtered, and when needed, heated air free of toxic agents. See NBC System illustration under Location and Description of Major Components.

ARMY OIL ANALYSIS PROGRAM (AOAP)

The Army Oil Analysis Program (AOAP) provides a way of sampling and testing the oil used in your carrier. It checks for excessive amounts of dirt, water, fuel, and wear metal. By detecting problem signs early, maintenance can be performed at a lower level and equipment reliability is improved. Two sampling valves are installed in your carrier. The engine AOAP sampling valve is located on the right side of the transmission. See Army Oil Analysis Program (AOAP) Sampling Valves illustration under Location and Description of Major Components.

LOCATION AND DESCRIPTIONS OF MAJOR COMPONENTS

6-TON TRACKED CARGO CARRIER – LEFT FRONT VIEW – M548A1

NOTE

Lifting eye may be removed if machine gun mounting kit is installed.

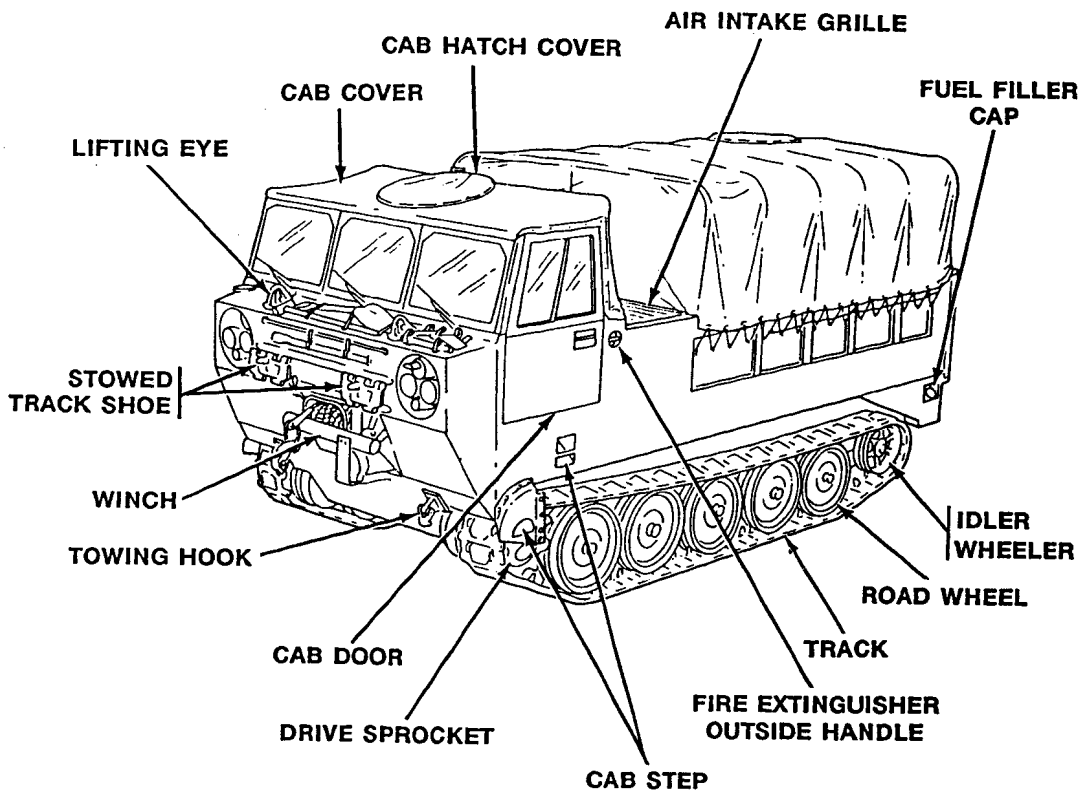

6-TON TRACKED CARGO CARRIER – RIGHT REAR VIEW – M548A1

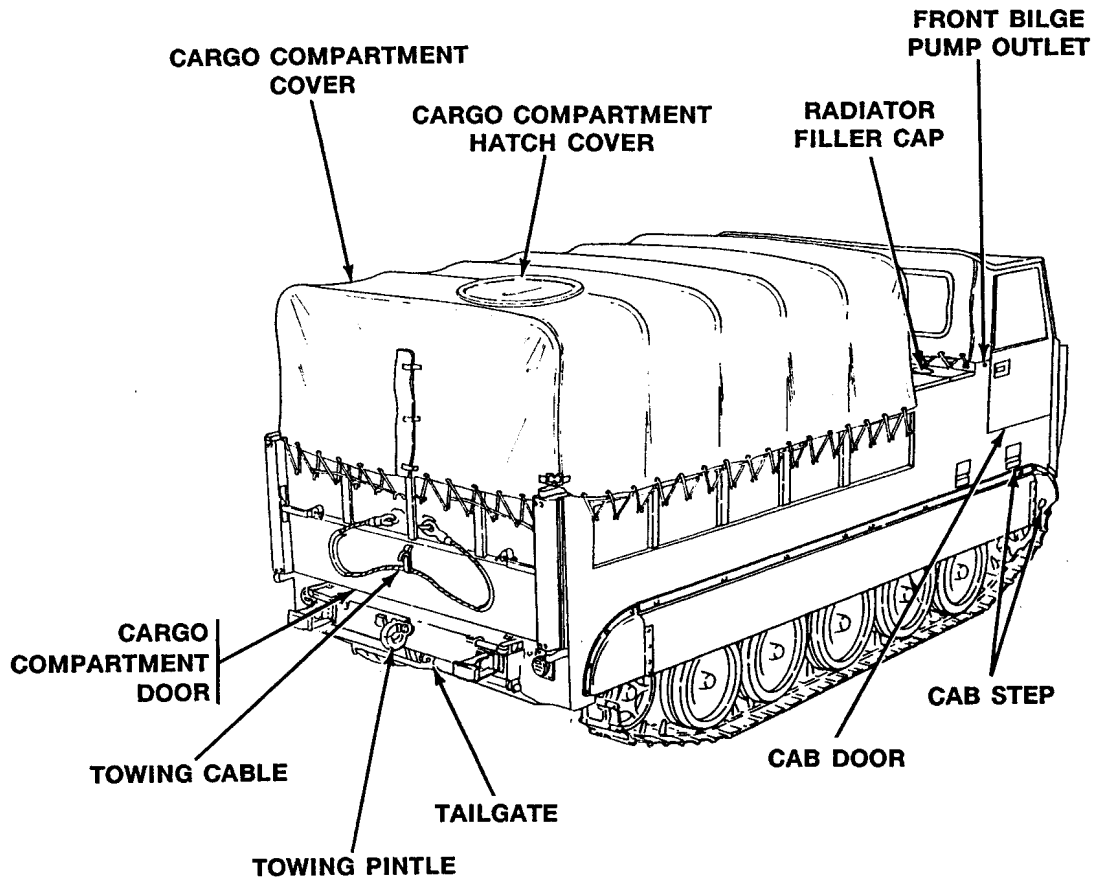

6-TON TRACKED CARGO CARRIER – FRONT VIEW – M548A1

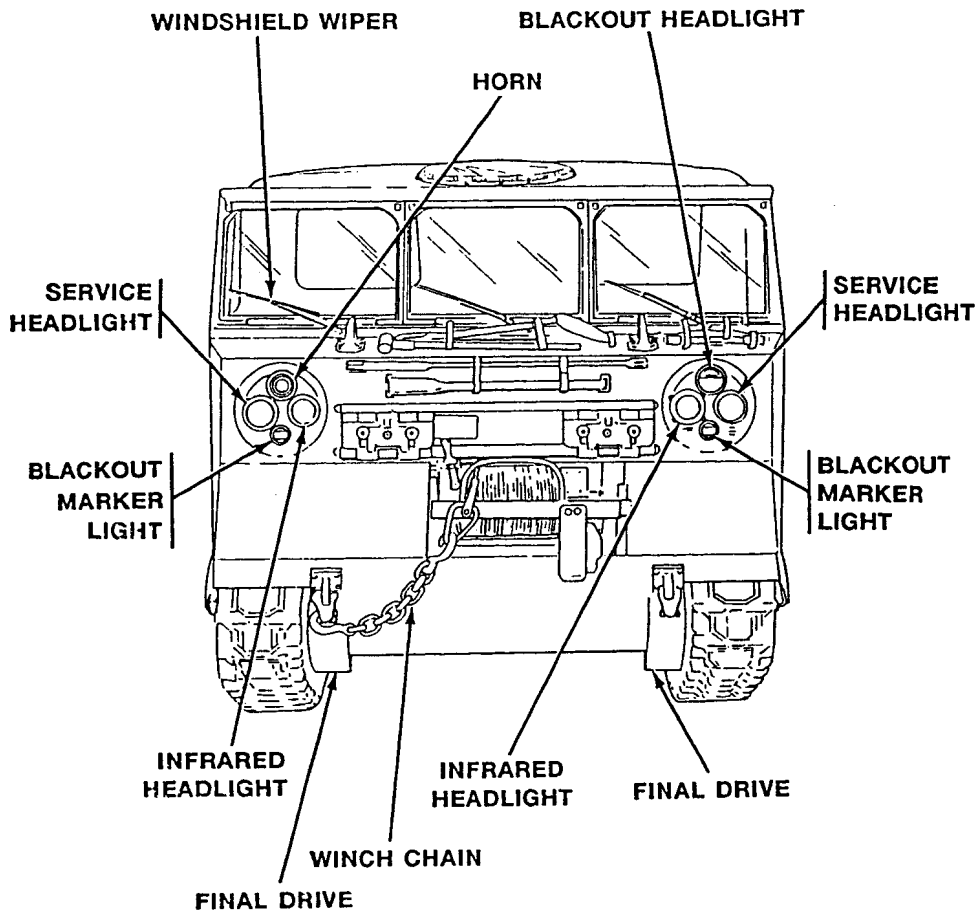

6-TON TRACKED CARGO CARRIER — REAR VIEW — M548A1

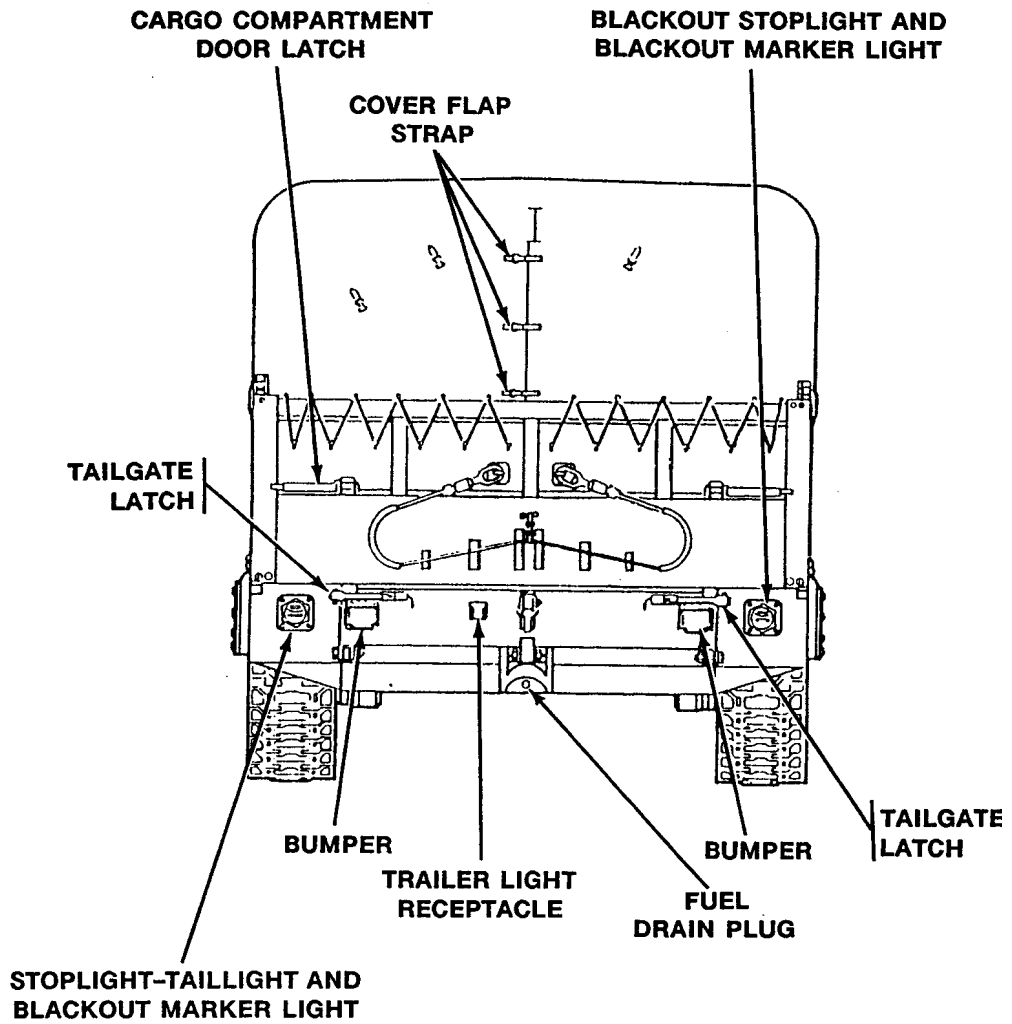

POWER PLANT COMPARTMENT — TOP VIEW — M548A1

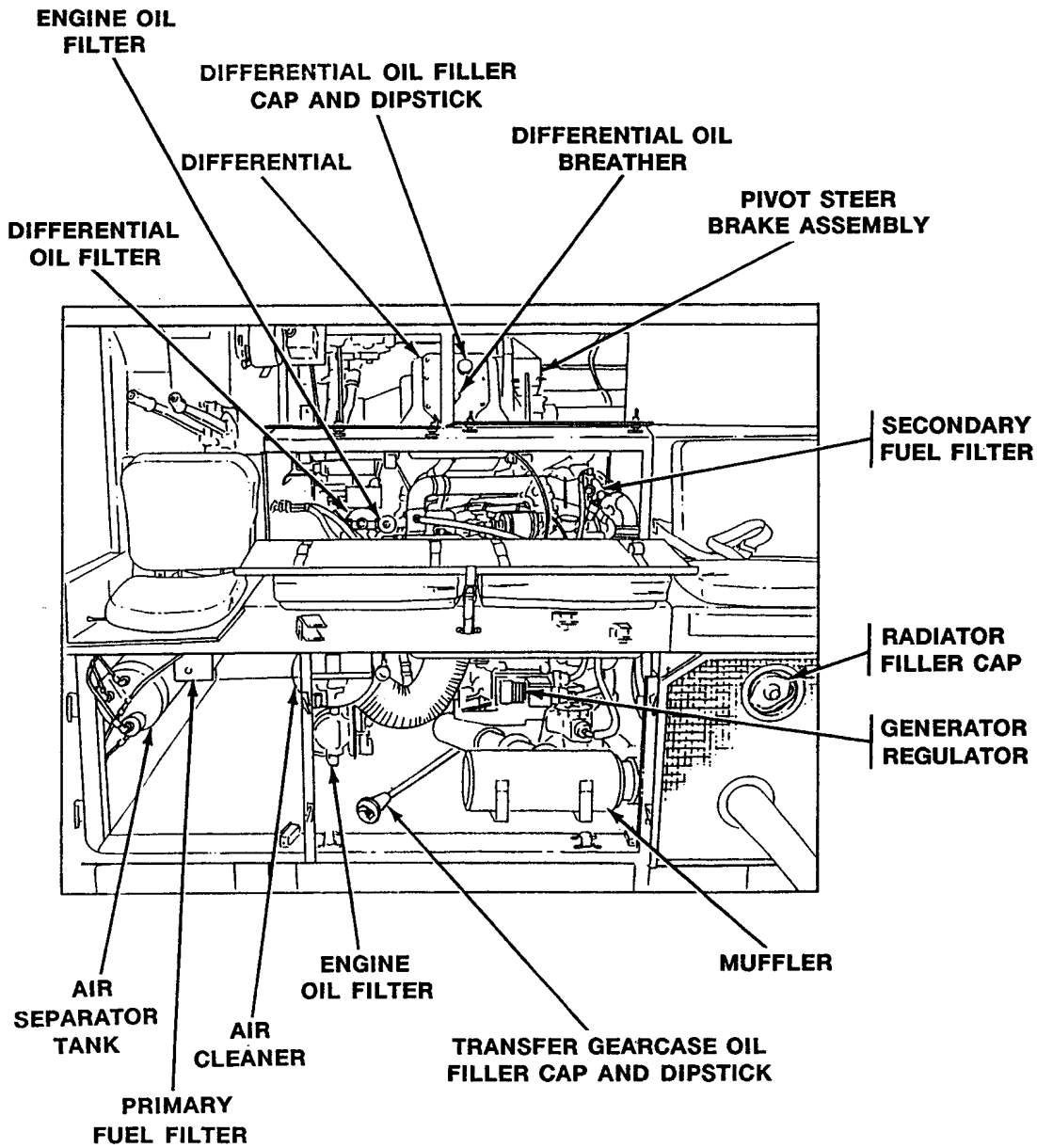

POWER PLANT COMPARTMENT – REAR VIEW – (CHX-1 THROUGH CHX-507 AND C-1 THROUGH C-3500)
– M548A1

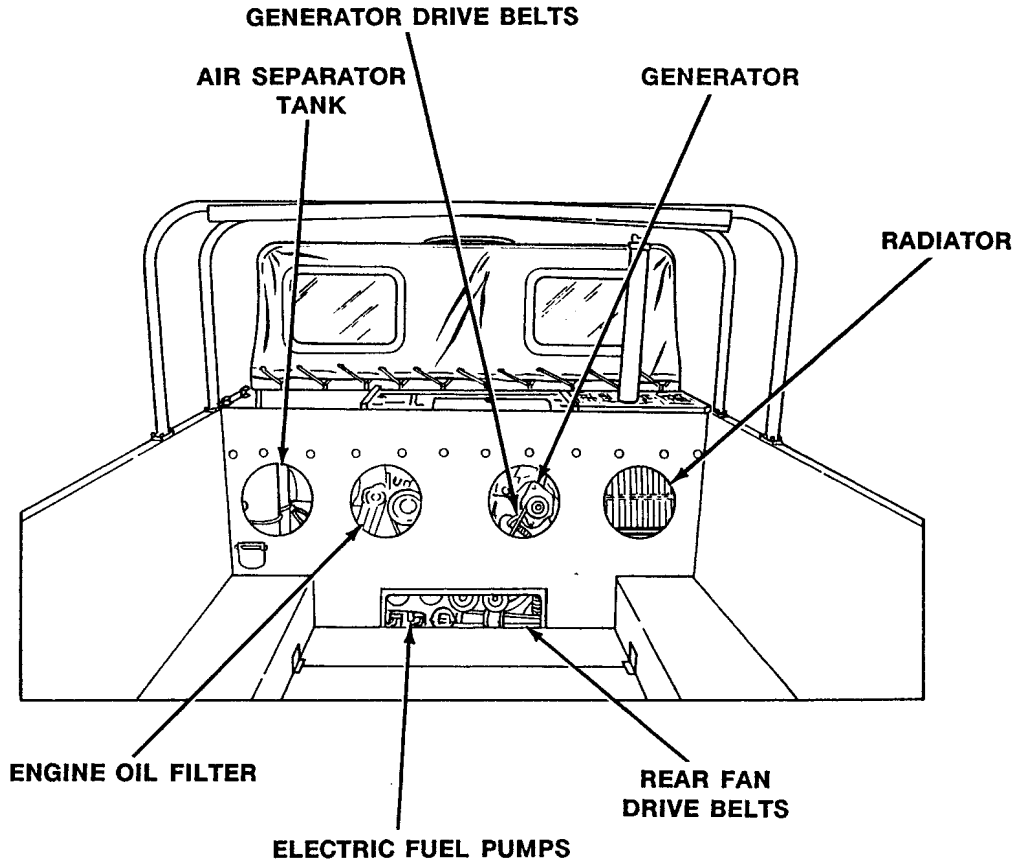

POWER PLANT COMPARTMENT — REAR VIEW — (AFTER CHX-507 AND C-3500) — M548A1

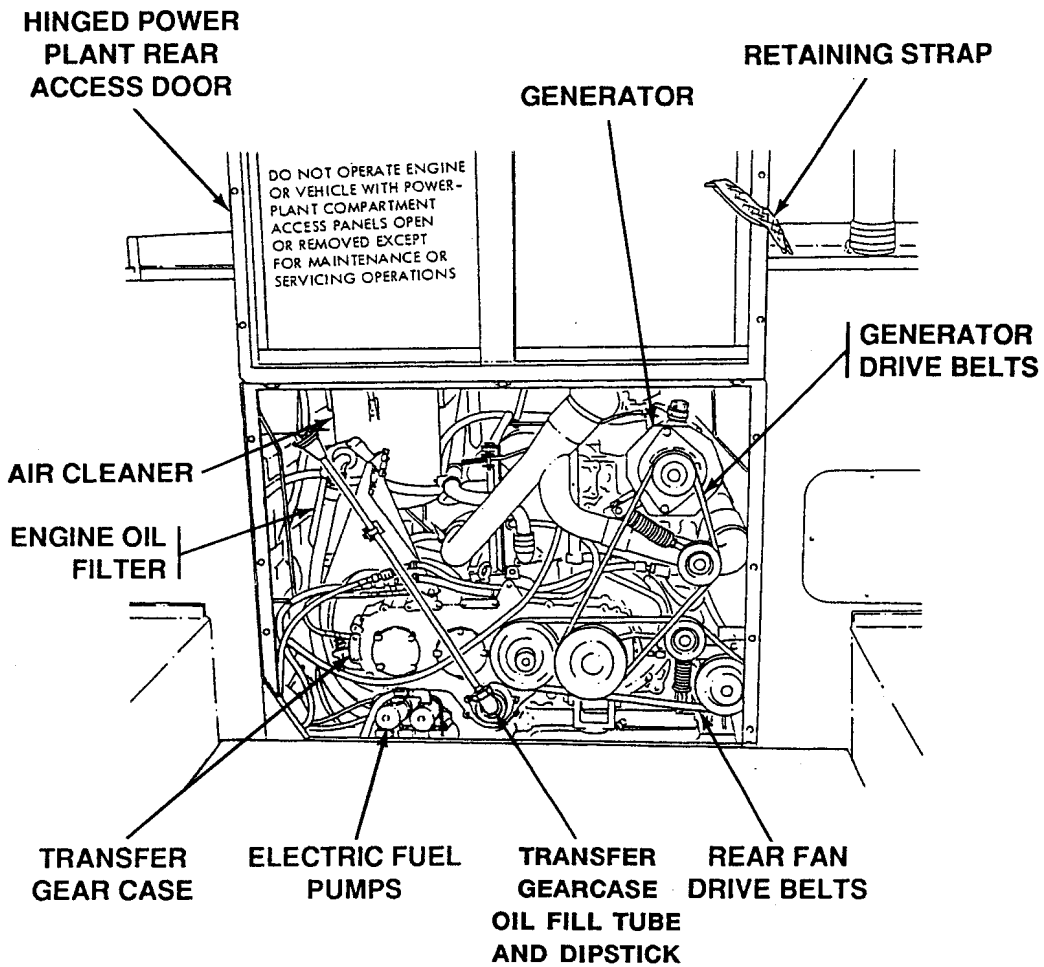

MATERIEL USED WITH CARRIER

MATERIAL HANDLING KIT

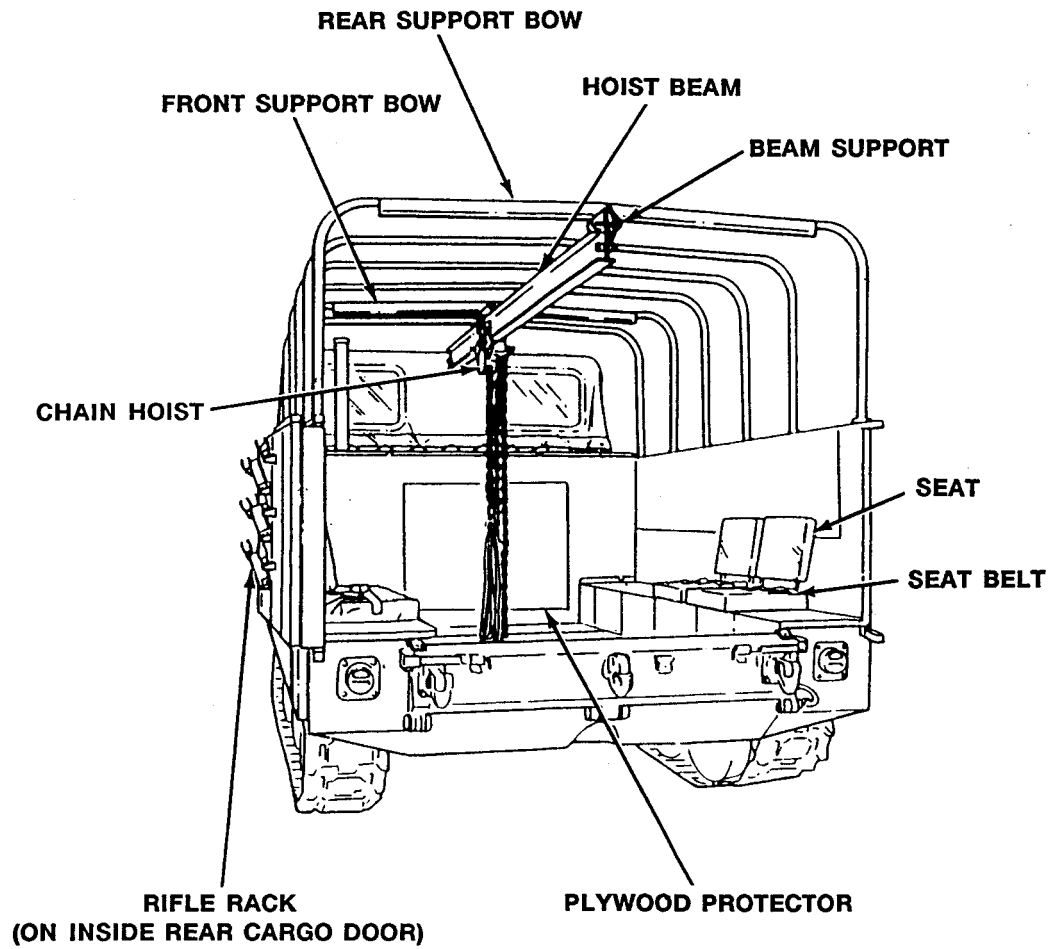

6-TON TRACKED CARGO CARRIER – LEFT FRONT VIEW – M548A3

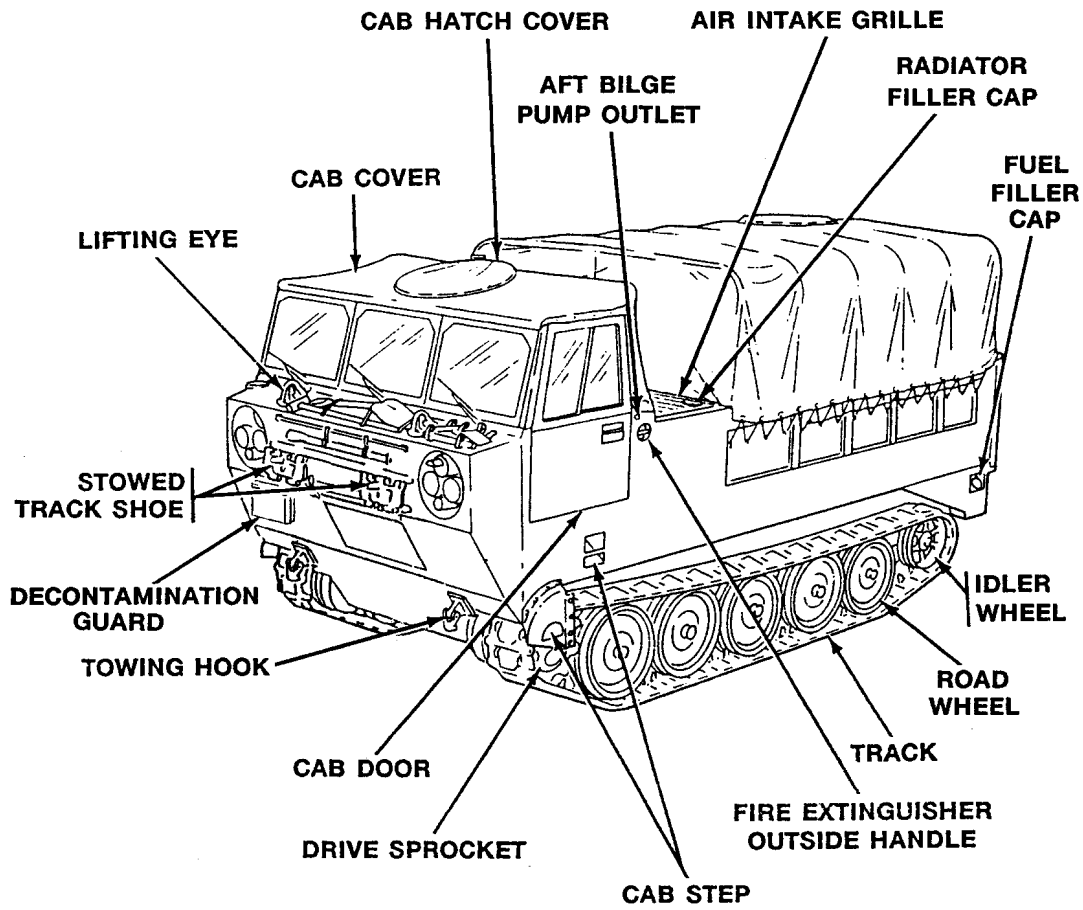

6-TON TRACKED CARGO CARRIER – RIGHT REAR VIEW – M548A3

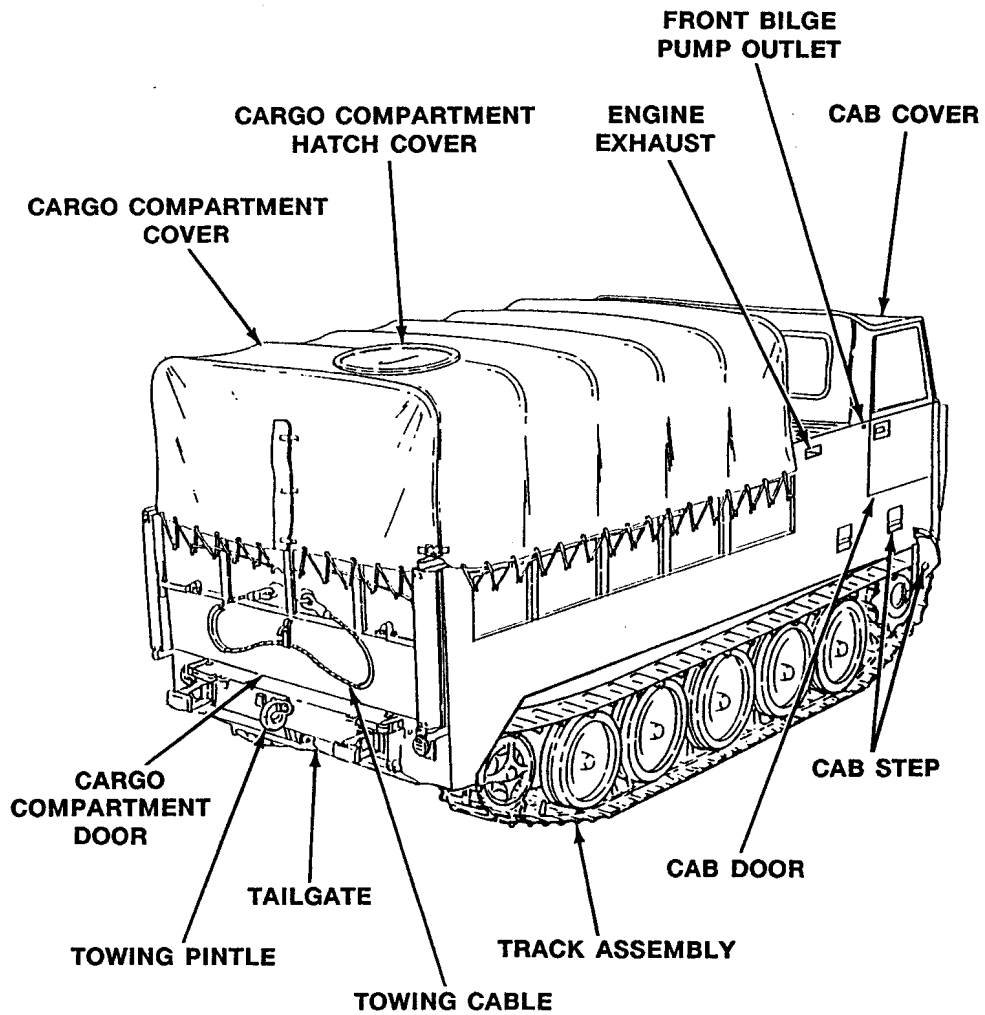

6-TON TRACKED CARGO CARRIER – FRONT VIEW – M548A3

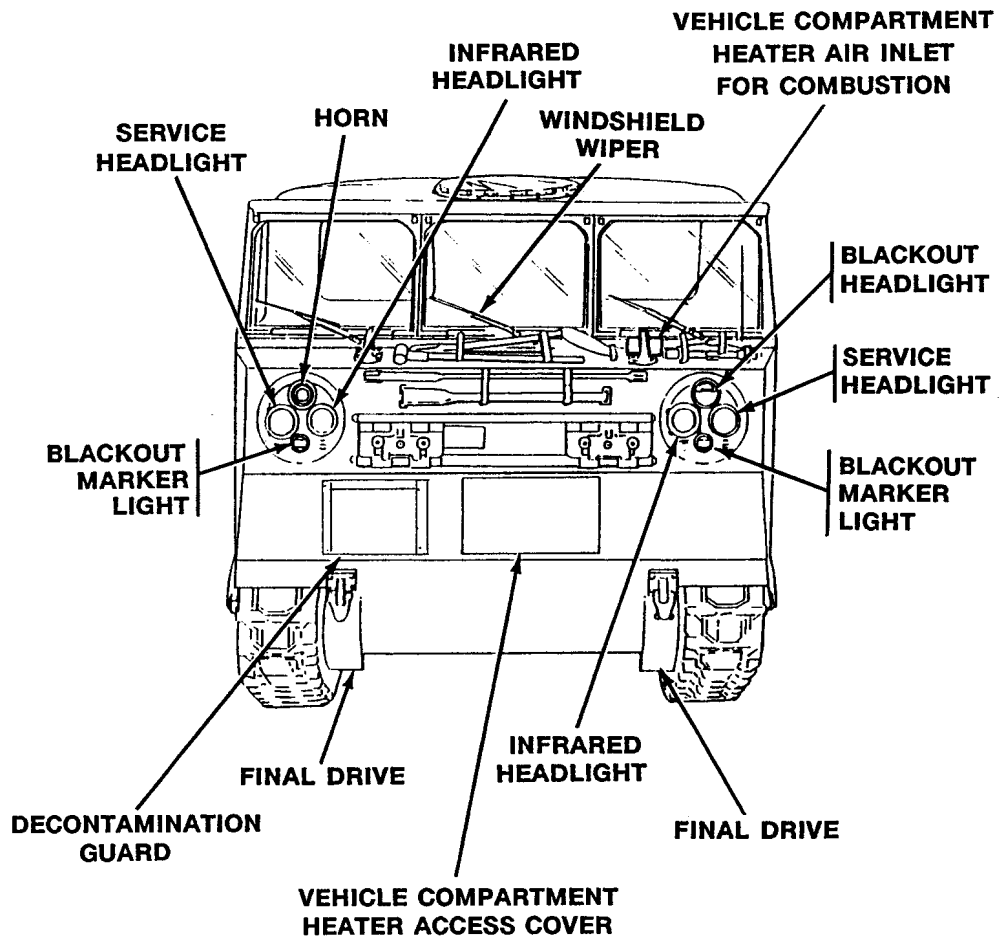

MATERIEL USED WITH CARRIER

AIR BRAKE KIT – M548A1

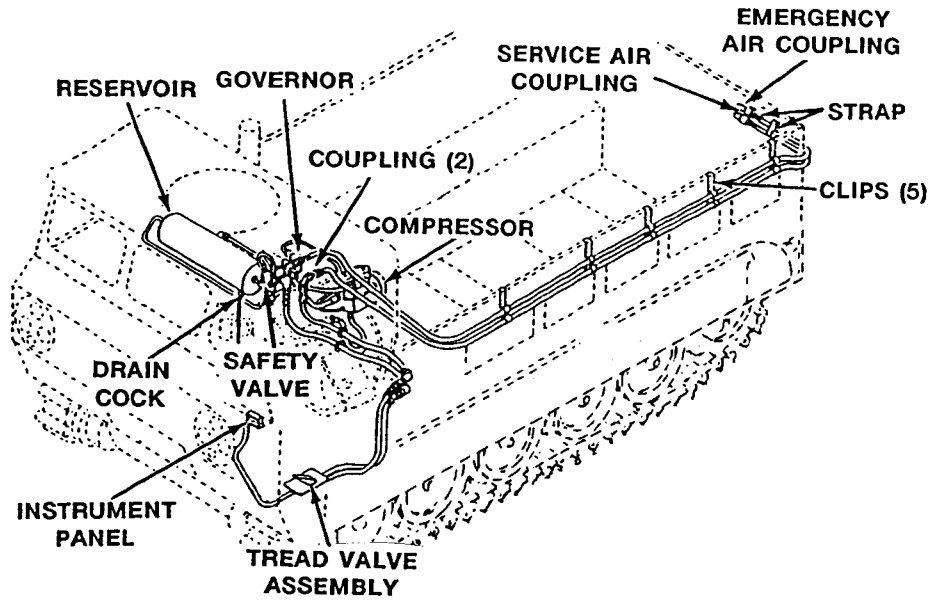

TURN SIGNAL KIT

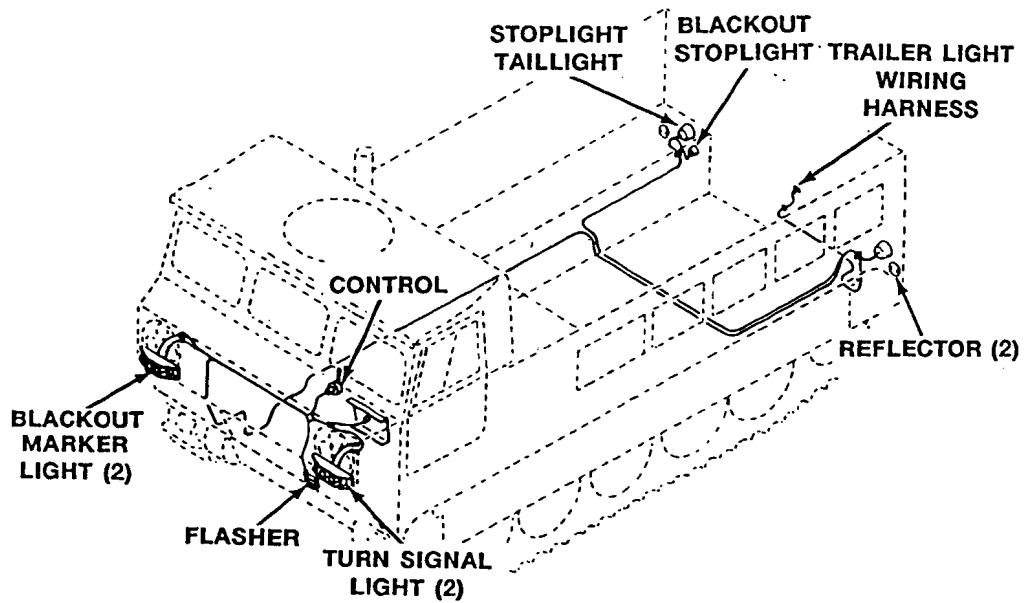

VEHICLE COMPARTMENT HEATER KIT - M548A1

KIT ONE

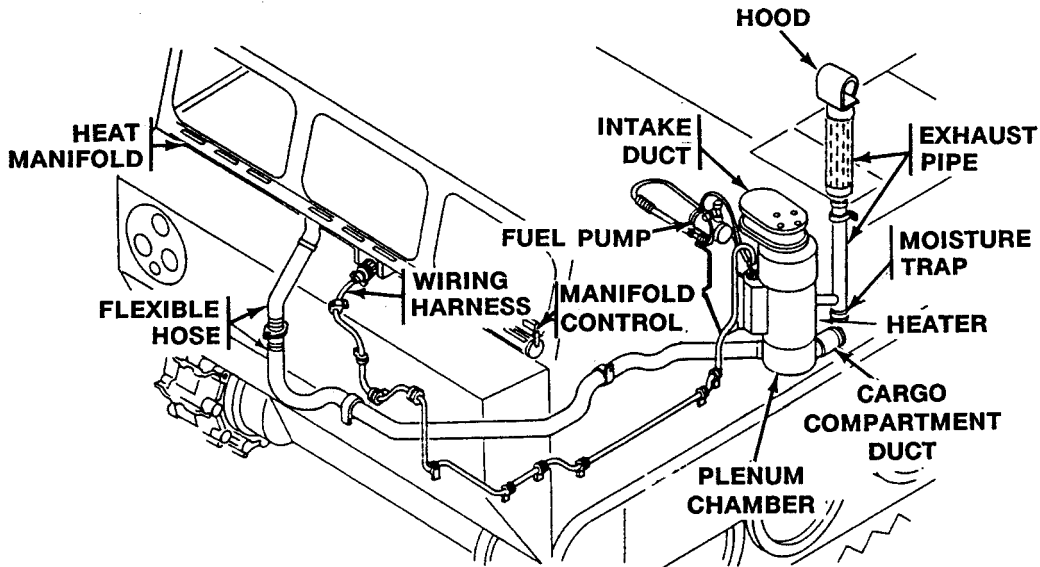

KIT TWO

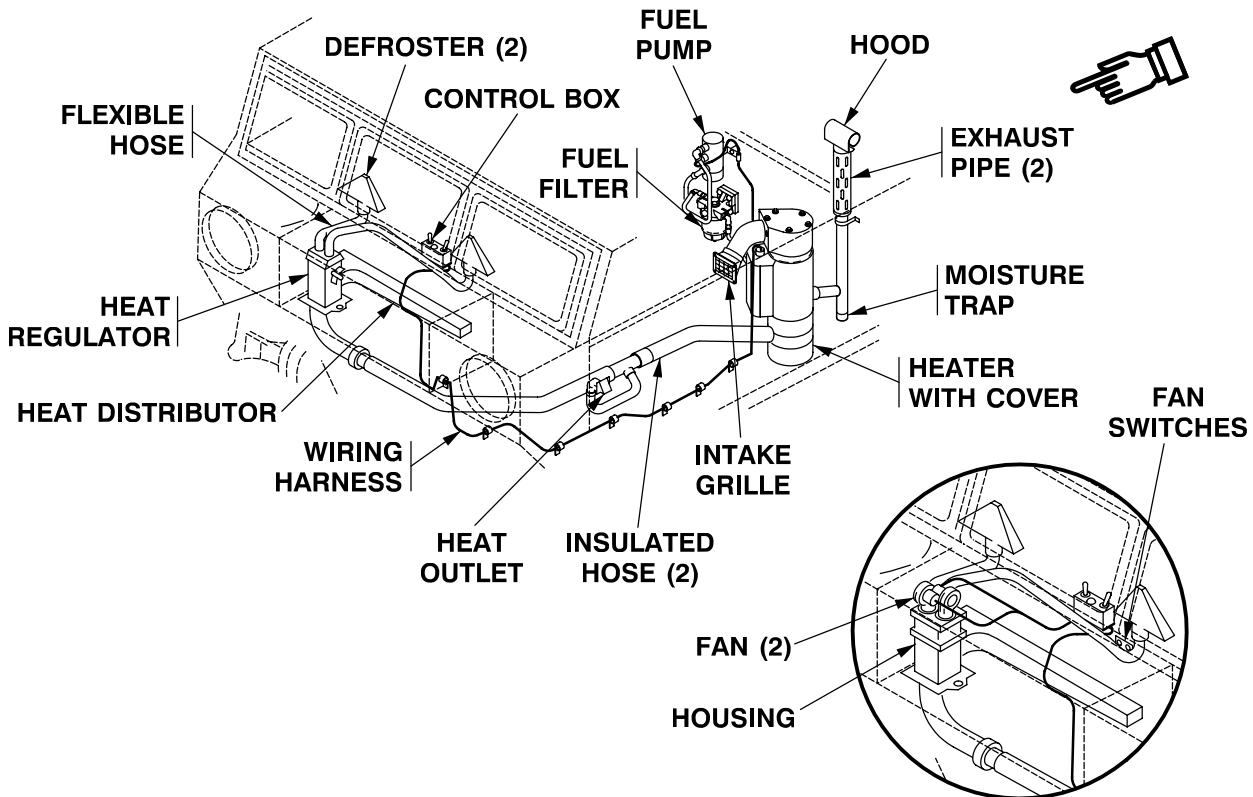

CARGO AREA (PRIMARY) VEHICLE COMPARTMENT HEATER KIT

KIT THREE

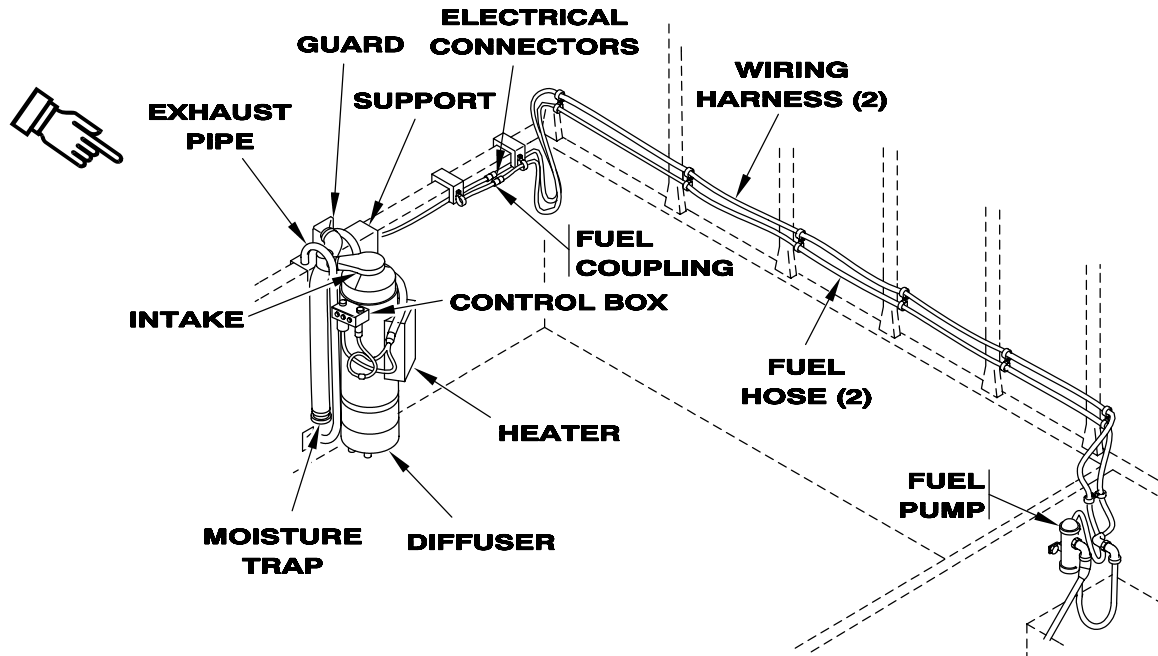

ENGINE COOLANT HEATER KIT – M548A1

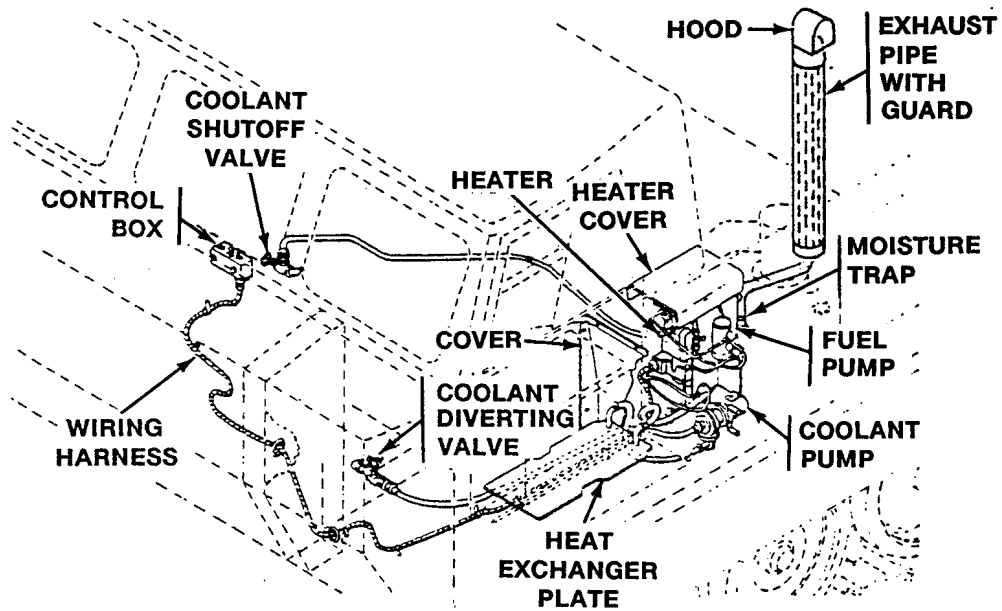

VEHICLE COMPARTMENT (SECONDARY) HEATER KIT

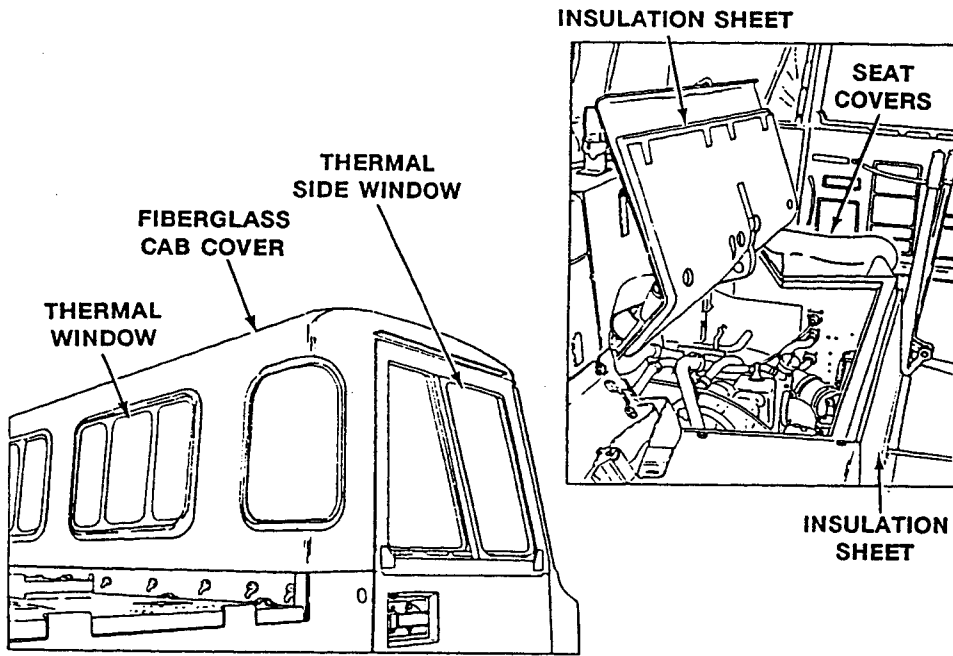

CARGO AREA (SECONDARY) VEHICLE COMPARTMENT HEATER KIT

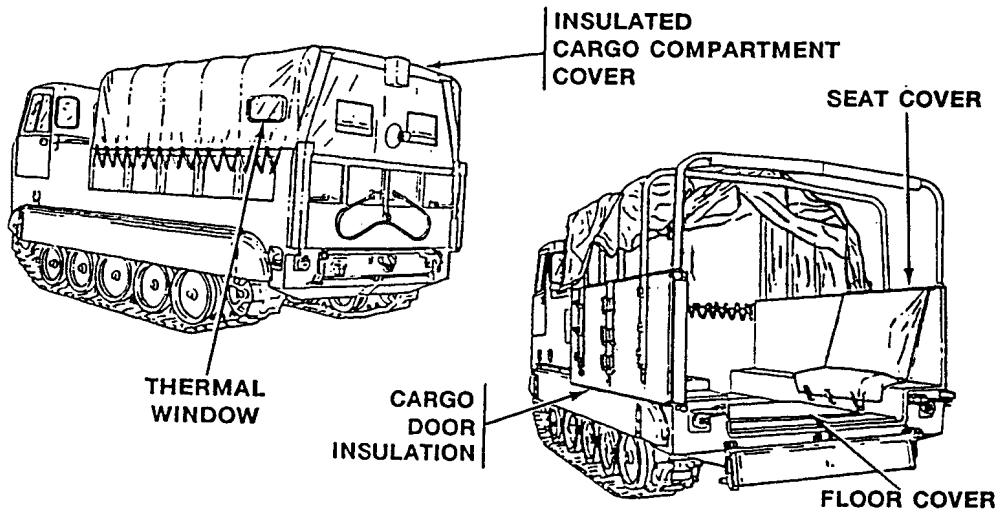

MACHINE GUN MOUNTING KIT (M66 MOUNT)

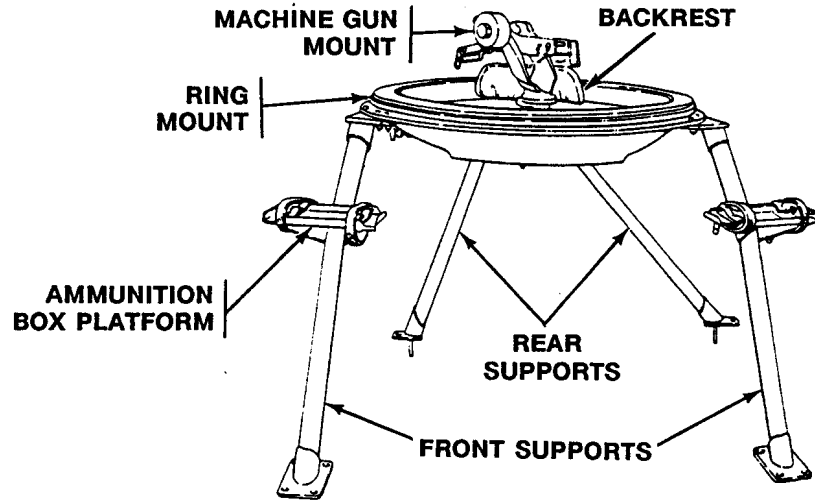

CAL .50 MACHINE GUN MOUNTING KIT (M49A1 MOUNT)

NOTE

Front lifting eyes are removed and stowed in cargo compartment under floor plates.

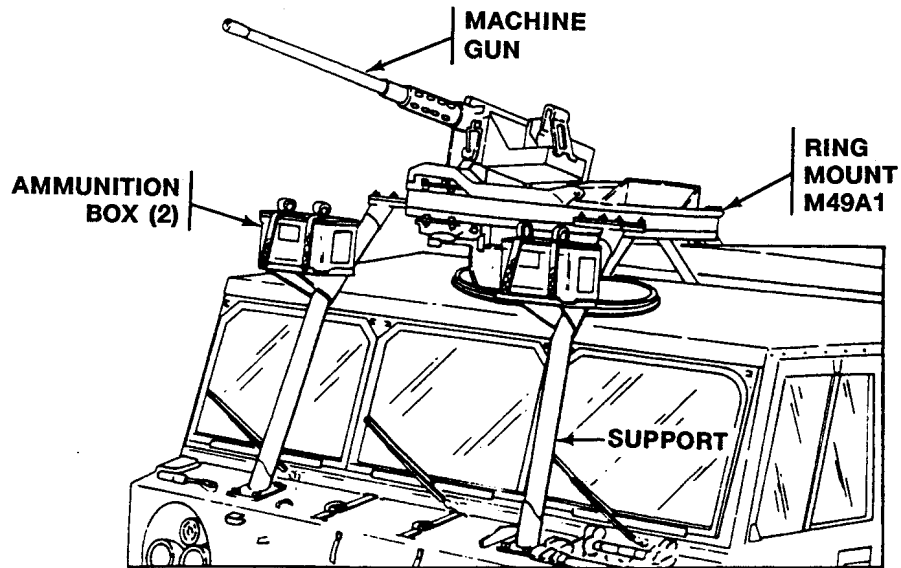

7.62 MM MACHINE GUN MOUNTING KIT

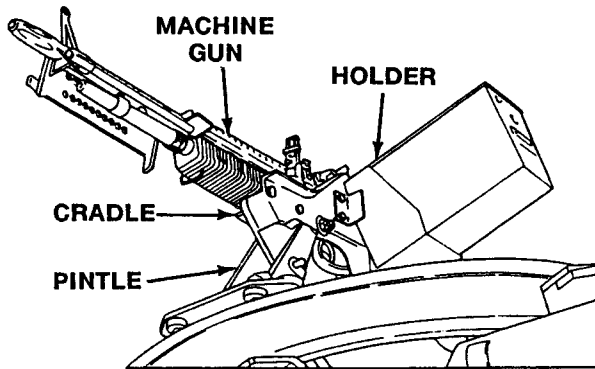

CAL .50 MACHINE GUN M2

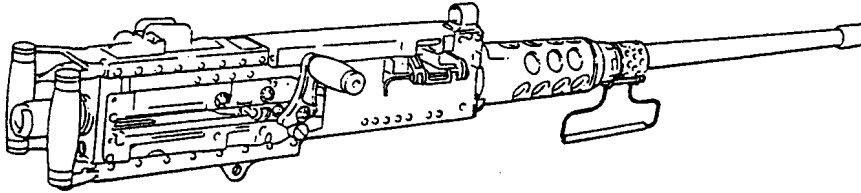

MACHINE GUN MOUNT M3

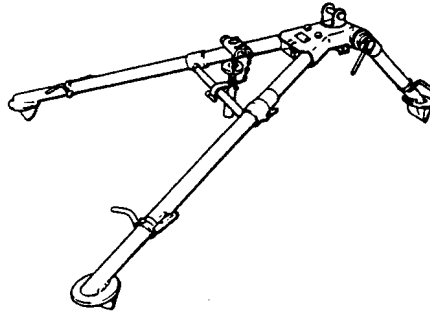

CAL 7.62 MM MACHINE GUN M60

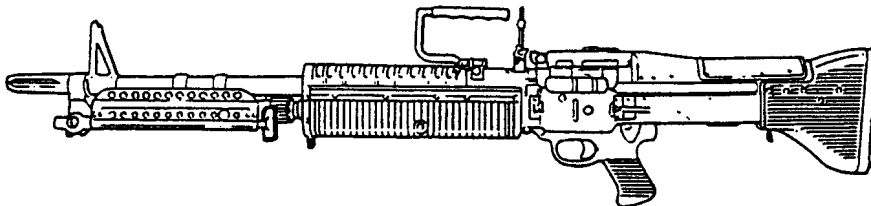

POWER PLANT COMPARTMENT – REAR VIEW – M548A3

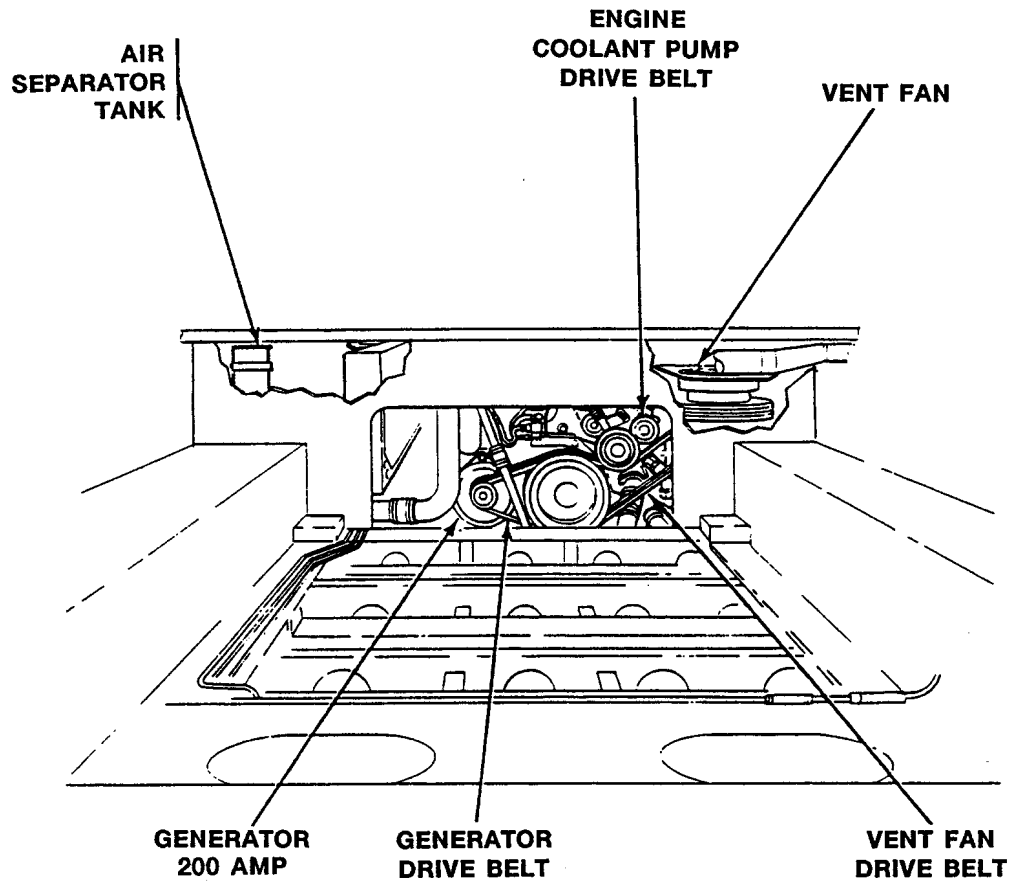

POWER TRAIN COMPONENTS – M548A3

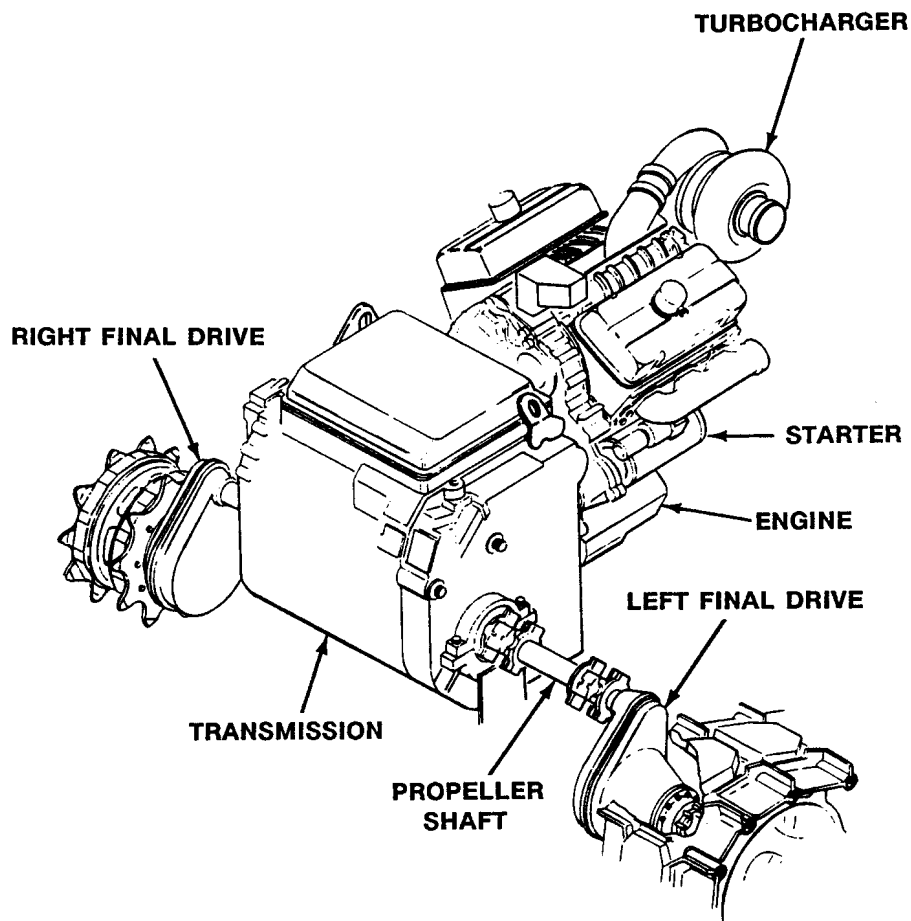

POWER PLANT COMPARTMENT – TOP VIEW – M548A3

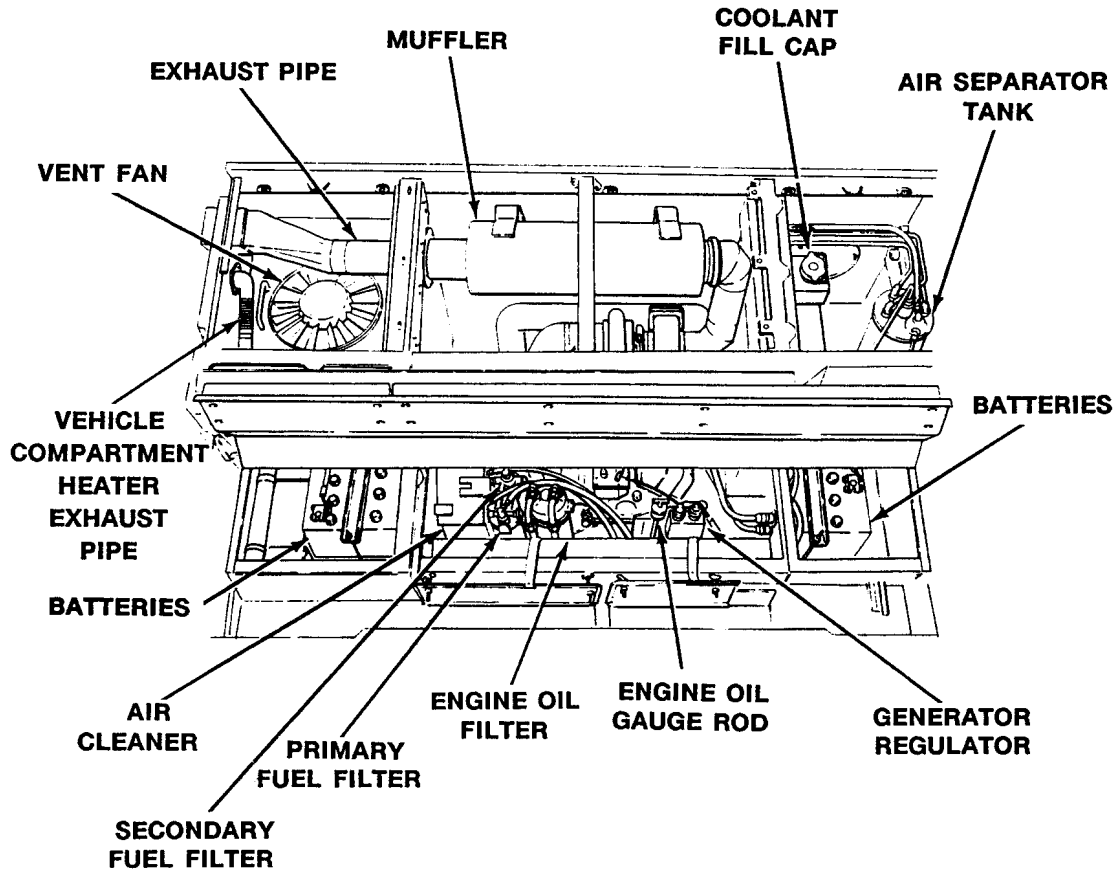

SUSPENSION SYSTEM COMPONENTS - M548A3

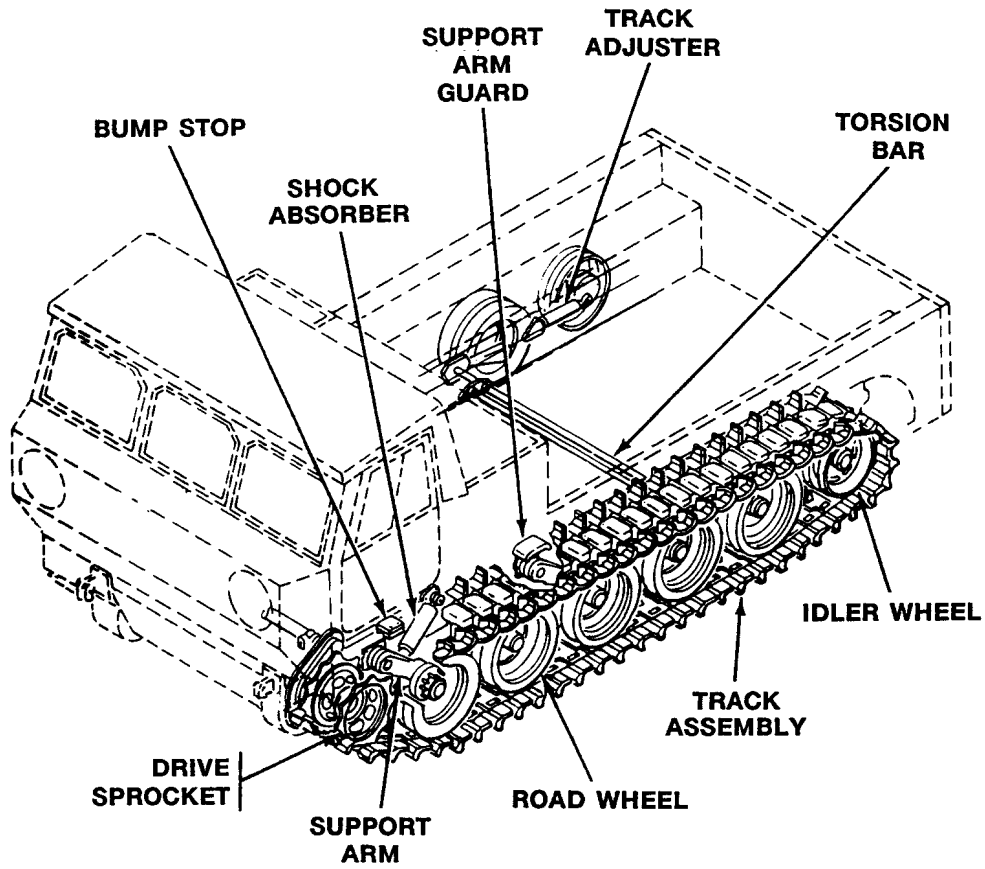

VEHICLE COMPARTMENT HEATER AND DEFROSTERS – M548A3

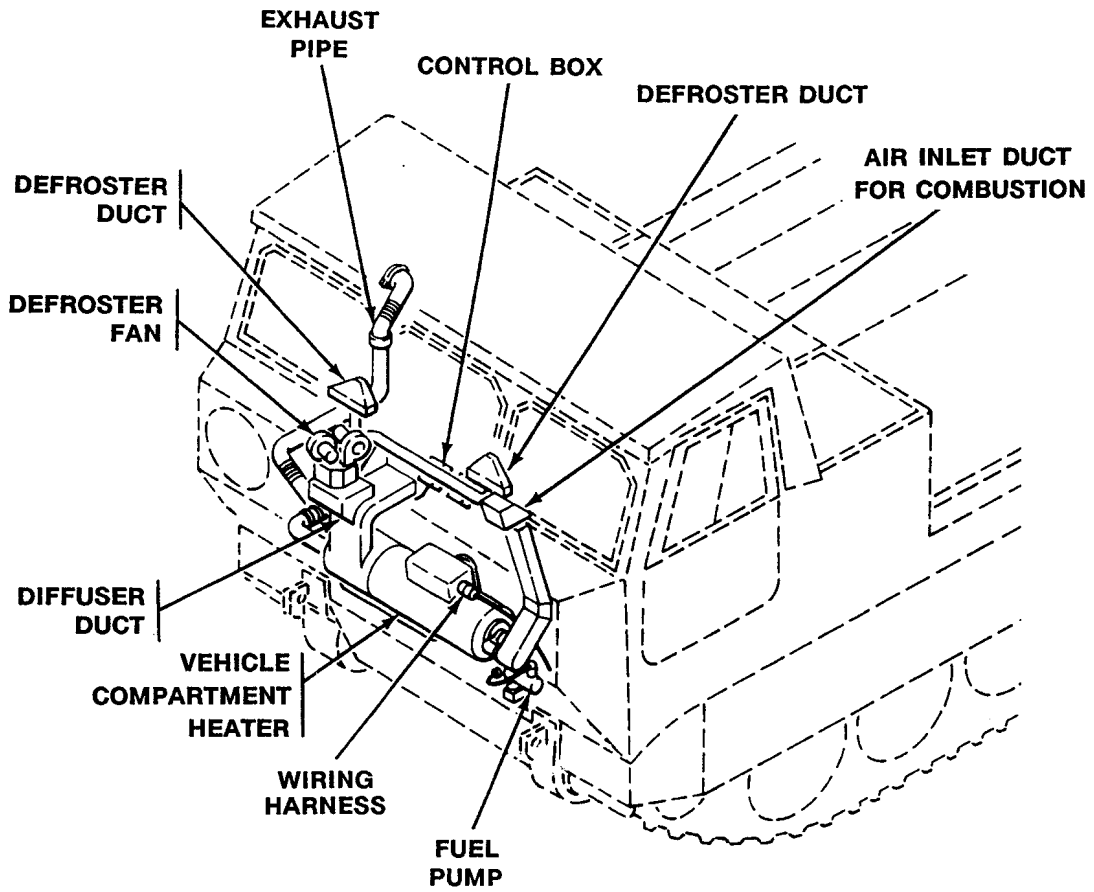

ENGINE COOLANT HEATER KIT - M548A3

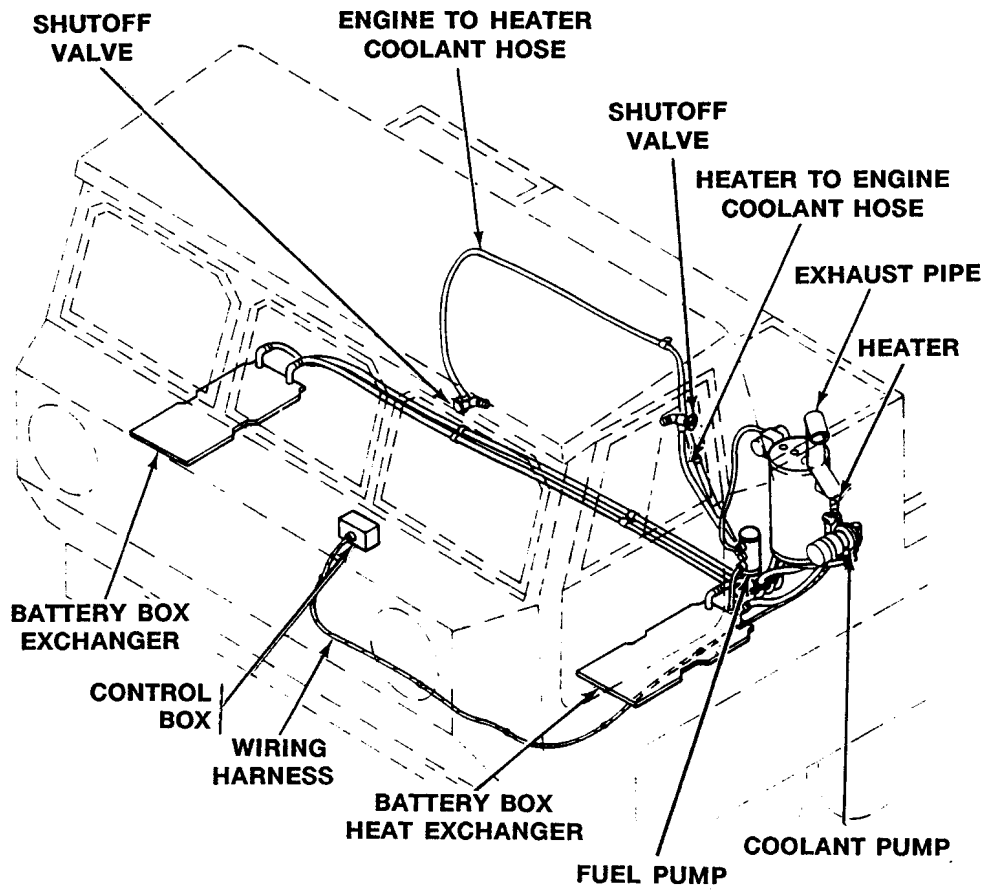

COOLING SYSTEM — M548A3

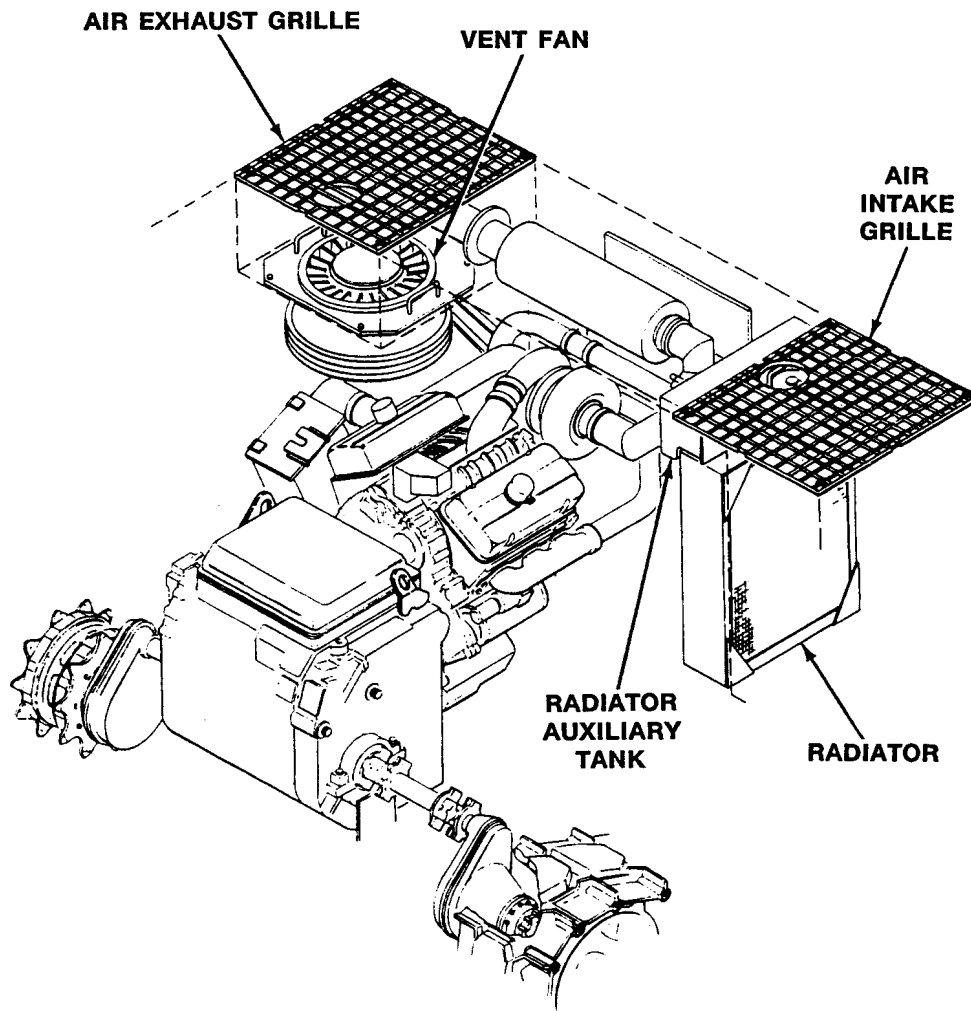

NUCLEAR, BIOLOGICAL, AND CHEMICAL (NBC) SYSTEM – M548A3

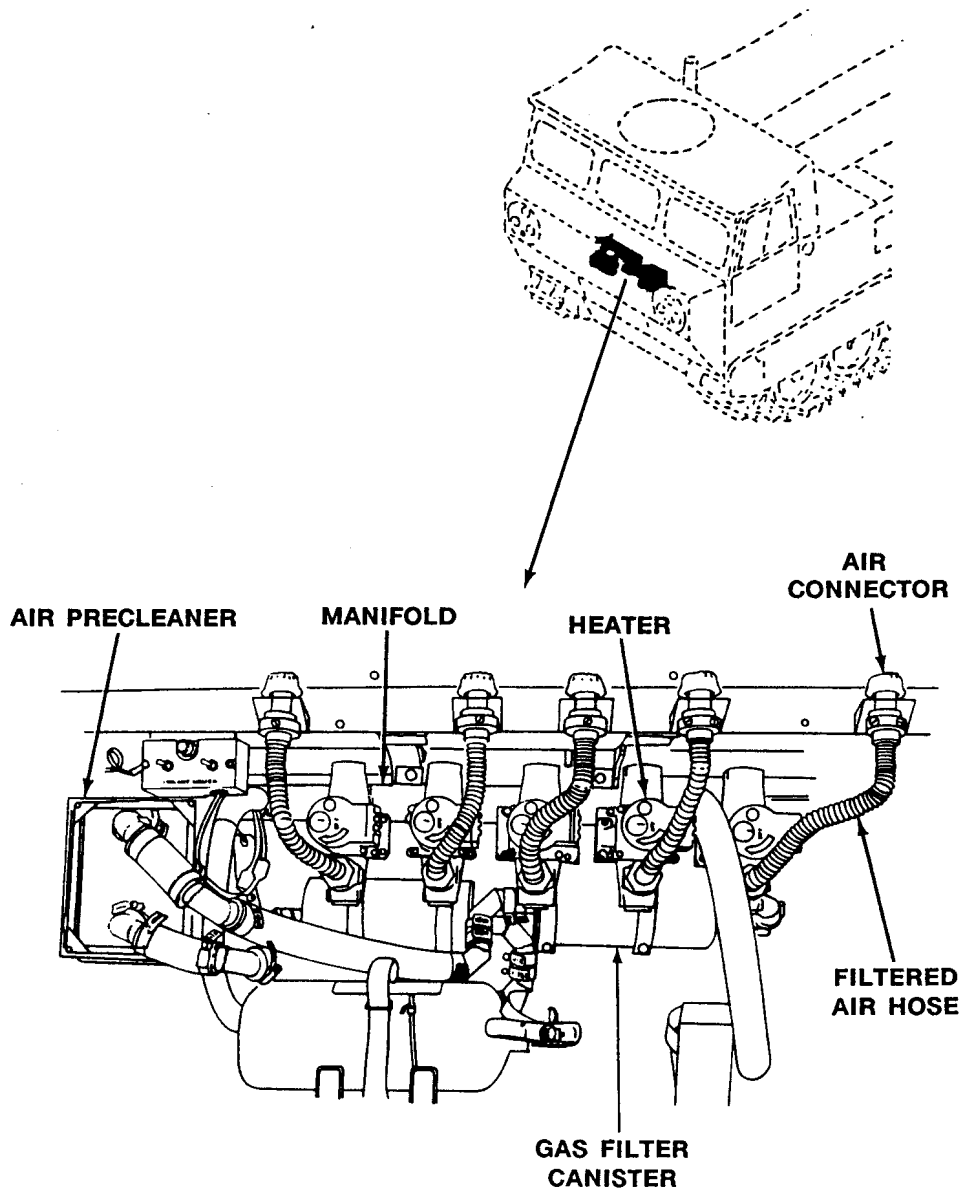

ARMY OIL ANALYSIS PROGRAM (AOAP) SAMPLING VALVES

NOTE

See PMCS for instructions on taking engine and transmission oil samples.

ENGINE AOAP
SAMPLING VALVE

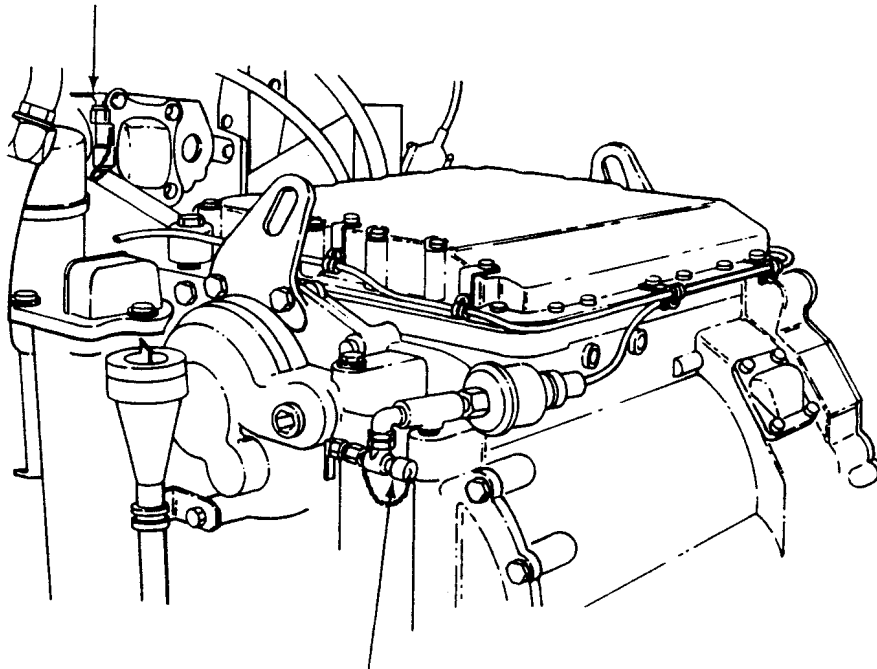

TRANSMISSION AOAP
SAMPLING VALVE

DIFFERENCES BETWEEN MODELS

Carriers with serial numbers (CHX-1 through CHX-507 and C-1 through C-3500) have four circular access panels and one small rectangular access panel in the power plant compartment rear bulkhead.

These carriers may or may not have shrouds and a rear bilge pump. Carriers with higher serial numbers and some rebuilt carriers have one large hinged access panel and two rectangular access panels in the power plant compartment rear bulkhead. These carriers do not have a rear bilge pump or shrouds and therefore do not swim.

CARRIERS WITH ROUND ACCESS PANELS:

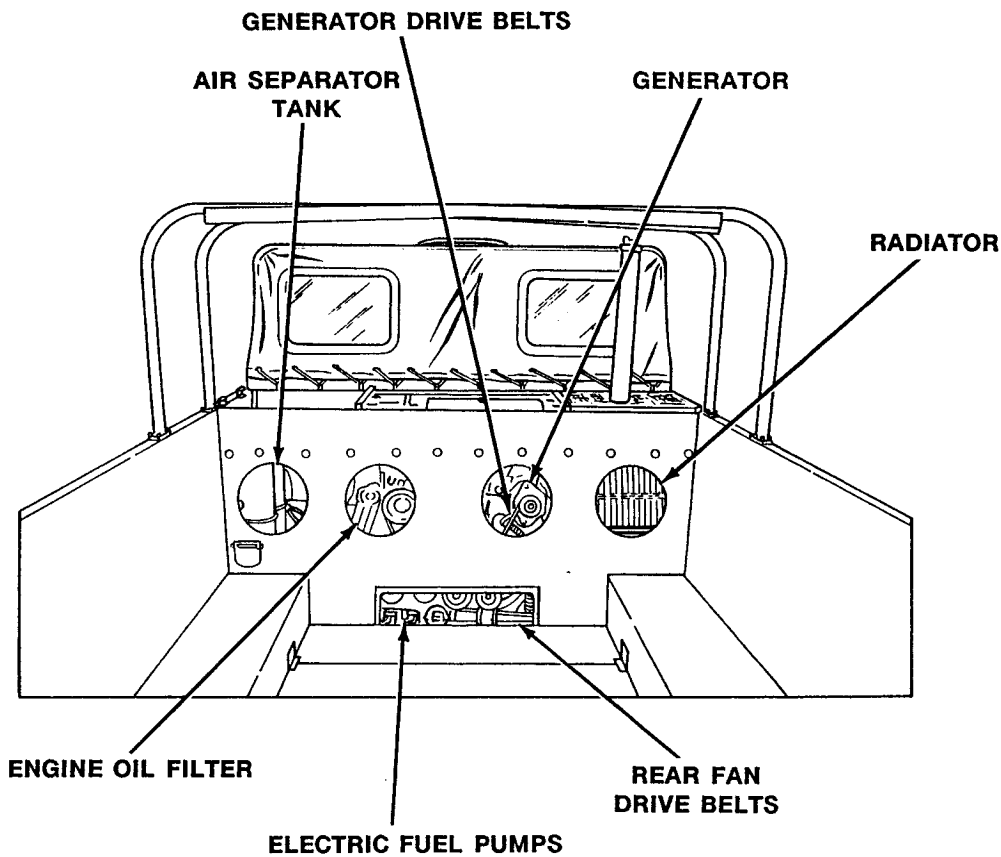

CARRIERS WITH RECTANGULAR ACCESS PANELS:

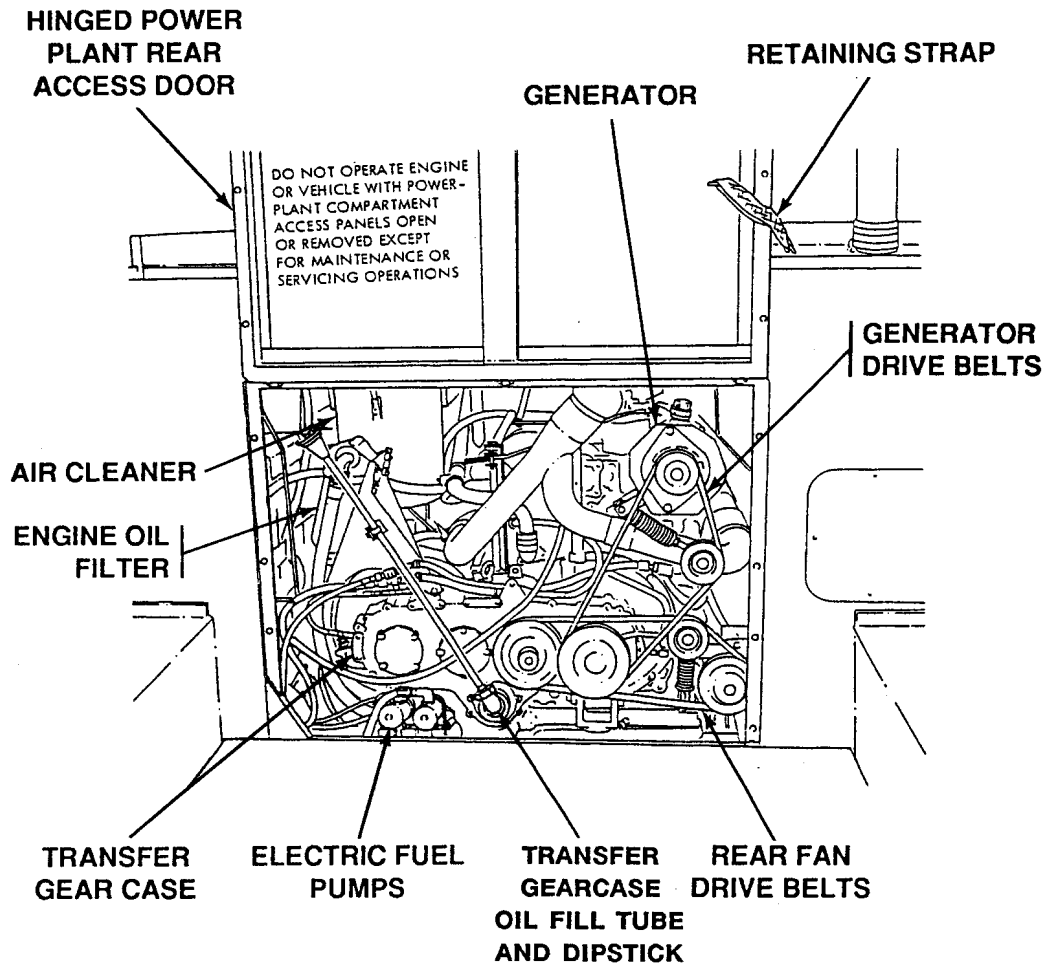

TABULATED DATA — CARRIER

Table 1. GENERAL

Crew	1 driver
Passengers	
In cab	3
In cargo compartment (with material handling kit)	4
Payload (heaviest)	12,000 lb (5,448 kg)
Cargo volume (biggest)	312 cu ft (8.74 cubic meters)

Table 2. SIZE

Length	227 in. (576.58 cm)
Width	
Widest (overall)	106 in. (269.24 cm)
Narrowest (track shrouds removed)	100 in. (254.00 cm)
Height	
To top of cab (M548A1)	107 in. (271.78 cm)
To top of hull (less cab and windshield)	77 in. (195.58 cm)
Ground clearance	17 in. (43.18 cm)
Cargo door opening (width)	97 in. (246.38 cm)
Tailgate opening (width)	64 in. (162.56 cm)
Cargo compartment	
Length	131 in. (332.74 cm)
Width	
Floor plates up	97 in. (246.38 cm)
Floor plates down	64 in. (162.56 cm)
Depth	
Floor plates up	46 in. (116.84 cm)
Floor plates down	53 in. (134.62 cm)
Track shoes (New)	66 each side

Table 3. WEIGHT

Fully loaded (gross weight) - with rated payload and driver	
With no kits	
M548A1	27,080 lb (12,294 kg)
M548A3	28,770 lb (13,062 kg)
With all kits	
M548A1	28,290 lb (12,844 kg)
M548A3	TBD

Unloaded (curb weight) includes driver, without payload	
With no kits	
M548A1	15,080 lb (6,846 kg)
M548A3	15,802 lb (7,174 kg)
Air transportable (unloaded) - without driver, but with 20% fuel	
M548A1	13,410 lb (6,088 kg)
M548A3	13,893 lb (6,307 kg)
Ground pressure	
At full load	
M548A1	8.5 psi (58.61 kPa)
M548A3	8.7 psi (59.99 kPa)
Unloaded	
M548A1	4.5 psi (31.03 kPa)
M548A3	4.8 psi (33.10 kPa)
Bridge weight classification	
Fully loaded	
M548A1	13
M548A3	14
Unloaded	
	7

Table 4. CENTER OF GRAVITY (UNLOADED)

Height above ground	
M548A1	31 in. (79.74 cm)
M548A3	29.3 in. (74.42 cm)
Distance behind centerline sprocket	
M548A1	68 in. (172.72 cm)
M548A3	64.2 in. (163.07 cm)

Table 5. PERFORMANCE

Fastest forward speed	
M548A1	
Range 1	10 mph (16.09 km/h)
Range 1-2	20 mph (32.18 km/h)
Range 1-3	38 mph (61.14 km/h)
Range 2-3	38 mph (61.14 km/h)

EQUIPMENT DESCRIPTION — Continued

0002 00

M548A3	
Range 1-4	38 mph (61.14 km/h)
Fastest reverse speed	
M548A1	9.2 mph (14.80 km/h)
M548A3	4.5 mph (7.24 km/h)
Cruising range	300 mi (482.8 km)
Shortest turning radius - pivot steering	
M548A1	14 ft (4.27 m)
M548A3	axis
Shortest turning radius - differential steering	
M548A1	24 ft (7.32 m)
Steepest grade (ascending or descending)	60 percent
Steepest side slope	30 percent
Highest wall climb	2 ft (0.61 m)
Widest trench crossing	5.5 ft (1.68 m)
Heaviest towed load	14,500 lb (6,583 kg)
Fording depth	40 in. (101.6 cm)

Table 6. ENGINE

Type	
M548A1	six-cylinder, V-type, two stroke diesel
M548A3	turbocharged, six-cylinder, V-type, two stroke diesel
Horsepower	
M548A1	210 at 2,800 rpm
M548A3	275 at 2,800 rpm
Idle speed	650-700 rpm
Maximum governed speed:	
Full load	2,800 rpm
No load	2,925 to 2,975 rpm
Firing order	1L, 3R, 3L, 2R, 2L, 1R
Coolant temperature range	
Normal - air temperature below 85°F (29°C)	160 - 200°F (71 - 93°C)
Normal - air temperature above 85°F (29°C)	230°F (110°C)

Fuel	
DF-2 (VV-F-800)	only at temperatures above 32°F (0°C)
DF-1 (VV-F-800)	only at temperatures above -10°F (-23°C)
DF-A (VV-F-800)	any temperature
CITE (MIL-F-46005)	any temperature
JP-5	emergency use above 40°F (4.44°C)

Table 7. WINCH (M548A1)

Wire rope size	5/8 in. (1.59 cm)
Wire rope length (longest)	200 ft (61 m)
Line pull (15 to 30 ft/min line speed)	20,000 lb (9,080 kg)
Load limit (1.8 ft/min line speed)	24,000 lb (10,896 kg)

Table 8. REFILL CAPACITIES

Coolant	
M548A1	9 1/2 gal (35.96 liter)
M548A3	14 gal (52.99 liter)
Oil	
Engine	18 qt (17.03 liter)
Transmission	
M548A1	16 qt (15.14 liter)
M548A3	12 gal (45.42 liter)
Differential (M548A1)	20 qt (18.92 liter)
Transfer gearcase (M548A1)	2 1/2 qt (2.37 liter)
Final drive (each)	3 1/2 qt (4.26 liter)
Winch transfer gearcase (M548A1)	1/4 pt (0.12 liter)
Generator speed increaser gear assembly (M548A1)	4 qt (3.78 liter)
Gear oil	
Winch gear box (M548A1)	2 3/4 pt (1.30 liter)
Winch end frame (M548A1)	3/4 pt (0.36 liter)
Hydraulic fluid	
Pivot steer master cylinder (each) (M548A1)	1/2 pt (0.24 liter)

Diesel fuel	
Capacity	100 gal (378.5 liter)
Safe filling rate	50 gpm (189.25 liter/min)

TABULATED DATA — MATERIEL USED WITH CARRIER

Table 9. MATERIAL HANDLING KIT

Crew	4
Weight (complete kit)	148 lb (67.19 kg)
Beam length	13.2 ft (4.03 m)
Lifting height (highest)	8 ft (2.44 m)
Lifting capacity (heaviest)	1,500 lb (681 kg)
Chain pull at heaviest capacity	60 lb (27.24 kg)

Table 10. AIR BRAKE KIT (M548A1)

Weight (complete kit)	90 lb (40.86 kg)
Governed pressure	85 to 105 psi (586.08 to 723.98 kPa)
Safety valve release pressure	150 psi (1,034.25 kPa)
Low pressure warning	1,500 lb (681 kg) 60 psi (413.7 kPa)

Table 11. CAB (PRIMARY) VEHICLE COMPARTMENT HEATER KIT

Weight (complete kit)	80 lb (36.32 kg)
Heat output	
High	60,000 Btu/hr
Low	30,000 Btu/hr
Fuel	carrier diesel fuel

Table 12. CARGO AREA (PRIMARY) VEHICLE COMPARTMENT HEATER

Weight (complete kit)	55 lb (25 kg)
Heat output	
High	60,000 Btu/hr
Low	30,000 Btu/hr
Fuel	carrier diesel fuel

Table 13. ENGINE COOLANT HEATER KIT

Weight (complete kit)	59 lb (27 kg)
Heat output	

High	16,000 Btu/hr
Low	5,500 Btu/hr
Fuel	carrier diesel fuel

Table 14. CAB (SECONDARY) VEHICLE COMPARTMENT HEATER KIT

Weight (complete kit)	140 lb (64 kg)
-----------------------	----------------

Table 15. CARGO AREA (SECONDARY) VEHICLE COMPARTMENT HEATER KIT

Weight (complete kit)	85 lb (39 kg)
-----------------------	---------------

Table 16. MACHINE GUN MOUNTING KIT (M66 MOUNT)

Weight (complete kit)	380 lb (173 kg)
Traverse	360°
Elevation (highest aim)	85°
Depression (lowest aim)	-15°

Table 17. CAL .50 OR 7.62 MM MACHINE GUN MOUNTING KIT

Weight	475 lb (216 kg)
Traverse	360°
Elevation (highest aim)	80°
Depression (lowest aim)	-20°

THEORY OF OPERATION

0003 00**GENERAL INFORMATION: M548A1**

The M548A1, 6-ton tracked cargo carrier is powered by a liquid cooled 6V53, 210 horsepower diesel engine. The engine power is converted to mechanical power and transferred to the carrier tracks and other components through a transfer gearcase, transmission, differential, and final drives.

The engine, transmission, and steering/braking system are driver controlled. Engine startup and shutdown are controlled by electrical signals and mechanical linkages connected to the accelerator pedal, the fuel shutoff cable, and the hand throttle cable. Steering/braking are controlled through linkages connected to the differential.

ENGINE AND DRIVE TRAIN

The engine converts air and diesel fuel into energy. The engine delivers this power to the transmission. A drive train transfers power from the engine to the carrier tracks. The drive train consists of the engine, transfer gearcase, transmission, differential, drive lines, final drive assemblies, and drive sprockets.

COOLING SYSTEM

The engine and transmission generate heat during normal operation. The cooling system transfers some of the heat to the outside to maintain a safe operating temperature. The vent fan draws air in through the radiator, circulates it around the power plant, and expels it through the exhaust grille above the vent fan. The vent fan is belt-driven from the engine crankshaft. A mixture of antifreeze and water is pumped through the cooling system to cool the engine and transmission. The engine cooling system has a capacity of 9.5 gallons (35.96 liters). The cooling system should be checked regularly. The auxiliary radiator tank, located on the transverse beam, provides space for the separation of air and liquid coolant. Stop engine if temperature goes above 200°F (93.3°C). See Cooling System illustration in Location and Description of Major Components (WP 0002 00). Refer to Check/Fill Cooling System (M548A1) (WP 0065 00).

COLD START SYSTEM

The engine is equipped with a cold start system (air box heater). The air box heater heats the air entering the cylinders to assist in ignition of fuel at low ambient temperatures (below 40°F (4.4°C)). A fuel and air mixture is sprayed into the air box and a spark ignites a flame. The flame heats the engine air, which is fed directly into the cylinders to make starting easier.

DIFFERENTIAL STEERING LEVERS

The differential steering levers are used to steer as well as stop the carrier. Pulling on one or both of the differential steering levers applies the brakes in the differential steering unit. To turn left, gradually pull on the left steering lever. To turn right, gradually pull on the right steering lever. To slow or stop the carrier, gradually pull both steering levers. To lock the steering levers in place, push down on the brake lock buttons, located on top of the steering levers. To release the steering levers brake-lock buttons, pull back on the steering levers and the buttons will pop up.

PIVOT STEER LEVERS

The pivot steer levers are used to steer the carrier while in water and to turn a stopped carrier in a tight turn. To pivot steer the carrier, bring the carrier to a stop and pull on the pivot steer lever. Pulling the pivot lever applies the disc brake, which will lock up the one track and allow all of the differential power to be applied to the other track.

TRANSMISSION SHIFT CONTROLLER

The transmission shifter is used to select driving range of transmission. The transmission shifter has six positions to choose from. See driver's controls (WP 0004 00) for a description of each position. There is a neutral safety switch to make sure the engine only starts with the transmission in neutral.

FUEL CUTOFF CONTROL

To start fuel flowing to the engine, push the fuel cutoff control all the way in. To stop fuel flow to the engine, pull the fuel cutoff control all the way out. This will shut down the engine when it is running.

HAND THROTTLE CONTROL

The hand throttle control is used to set the engine speed for various reasons. To set the engine speed, while pushing down the accelerator pedal, pull hand throttle control out until desired rpm is indicated by tachometer. Turn the hand throttle control clockwise to lock the control and counterclockwise to release the control. Once the hand throttle control is set, the engine will maintain the set speed without holding down the accelerator pedal.

MAIN LIGHT SWITCH

The main light switch is used to control all of the exterior lights and the instrument panel lights. To select lights, push up and hold the UNLOCK lever before moving desired lever to the position wanted. Refer to Operate Carrier Lights (WP 0032 00).

AIR CLEANER INDICATOR

The air cleaner indicator indicates if the air cleaner is operating properly or is plugged. When the air cleaner indicator is red, the air cleaner is plugged and needs cleaning. Press rubber dome to reset air cleaner indicator after air cleaner has been replaced or cleaned.

WINCH

The winch is for self-recovery or to recover another vehicle. For operation of winch, refer to WP 0030 00.

FIXED FIRE EXTINGUISHER

Refer to WP 0033 00 for operation of the fixed fire extinguisher.

BATTERY GENERATOR GAUGE

The battery generator gauge has the color red repeated. The first (left to right) red position indicates the batteries are dead (no power). The second red position indicates the batteries are being overcharged and could possibly blow up. During normal operation, the gauge should be in the green position. Refer to WP 0018 00 for other colors.

TACHOMETER GAUGE

The tachometer indicates engine speed and hours of operation. To read engine speed (RPM), multiply the large numbers on the gauge by 100, or add two zeros to number.

GENERAL INFORMATION: M548A3

The M548A3, 6-ton tracked cargo carrier is powered by a turbocharged, liquid cooled 6V53, 275 horsepower diesel engine. The engine power is converted to mechanical power and transferred to the carrier tracks and through a hydro-mechanical cross drive transmission and final drives.

The engine, transmission, steering system, and braking system are driver controlled. Engine startup and shutdown are controlled by electrical signals and mechanical linkages connected to the accelerator pedal, the fuel shutoff cable, and the hand throttle cable. Steering and braking are controlled through linkages connected to the transmission. The hand brake is hand controlled with assistance from pressing on the brake pedal.

ENGINE AND DRIVE TRAIN

The engine converts air and diesel fuel into energy. The engine delivers this power to the transmission, variable fan speed and alternator drive. The variable fan speed and alternator drive drives the alternator and cooling fan. Air for combustion flows through the air cleaner, turbocharger, and the engine. A drive train transfers power from the engine to the carrier tracks. The drive train consists of the engine, transmission, drive lines, final drive assemblies, and drive sprockets.

COOLING SYSTEM

The engine and transmission generate heat during normal operation. The cooling system transfers some of the heat to the outside to maintain a safe operating temperature. A mixture of antifreeze and water is pumped through the cooling system to cool the engine and transmission. Stop engine if temperature goes above 220°F (104.4°C). The engine cooling system has a capacity of 13.3 gallons (50.34 liters). The cooling system should be checked regularly. Refer to Check/Fill Cooling System (M548A3) (WP 0066 00).

COLD START SYSTEM

The engine is equipped with a cold start system (glow plugs). The glow plugs assist the engine starting at low ambient temperatures (below 40°F (4.4°C)). It consists of glow plugs, which are installed in the cylinder heads, and a controller that regulates the starting cycle and preglow/afterglow duration.

STEERING AND BRAKING

The steering and braking systems are an integral part of the cross drive transmission. The main controls are located in the driver's compartment. Center the steering wheel and set the transmission controller to the SL (steering lock) position whenever the carrier is being started, idling, or shut down. The steering wheel is locked manually by the driver. If the steering wheel is not centered and locked, the carrier will turn (pivot) regardless of the position of the transmission controller.

STEERING WHEEL AND STEERING WHEEL LOCK PIN

The steering wheel controls direction of carrier travel on land or water. The steering wheel lock pin locks the steering wheel in the center position to prevent pivoting the carrier when starting, warming up, or cooling down the engine.

TRANSMISSION SHIFT CONTROLLER

The transmission shifter is used to select driving range of transmission. The transmission shift controller has seven positions to choose from. See driver's controls (WP 0004 00) for a description of each position.

FUEL CUTOFF CONTROL

To start fuel flowing to the engine, push the fuel cutoff control all the way in. To stop fuel flow to the engine, pull the fuel cutoff control all the way out. This shuts down or stops the engine from operating.

HAND THROTTLE CONTROL

The hand throttle control is used to set the engine speed for various reasons. To set the engine speed, while pushing down the accelerator pedal, pull hand throttle control out until desired rpm is indicated by tachometer. Turn the hand throttle control clockwise to lock the control and counterclockwise to release the control. Once the hand throttle control is set, the engine will maintain the set speed without holding down the accelerator pedal.

MAIN LIGHT SWITCH

The main light switch is used to control all of the exterior lights and the instrument panel lights. To select lights, push up and hold the UNLOCK lever before moving desired lever to the position wanted. Refer to Operate Carrier Lights (WP 0032 00).

AIR CLEANER INDICATOR

The air cleaner indicator indicates if the air cleaner is operating properly or is plugged. When the air cleaner indicator is red, the air cleaner is plugged and needs cleaning. Press rubber dome to reset air cleaner indicator after air cleaner has been replaced or cleaned.

FIXED FIRE EXTINGUISHER

Refer to WP 0033 00 for operation of the fixed fire extinguisher.

BATTERY GENERATOR GAUGE

The battery generator gauge has the color red repeated. The first (left to right) red position indicates the batteries are dead (no power). The second red position indicates the batteries are being overcharged and could possibly blow up. During normal operation, the gauge should be in the green position. Refer to WP 0019 00 for other colors.

TACHOMETER GAUGE

The tachometer indicates engine speed and hours of operation. To read engine speed (RPM), multiply the large numbers on the gauge by 100, or add two zeros to number.

CHAPTER 2

OPERATOR INSTRUCTIONS

WORK PACKAGE INDEX

<u>Title</u>	<u>Sequence No.</u>
DESCRIPTION AND USE OF DRIVER'S CONTROLS AND INSTRUMENTS.....	0004 00
OPEN/CLOSE CARGO COMPARTMENT DOOR AND TAILGATE.....	0005 00
REMOVE/INSTALL TOP ACCESS COVER AND GRILLES (M548A3).....	0006 00
REMOVE/INSTALL CARGO COMPARTMENT FLOOR PLATES.....	0007 00
OPEN/CLOSE CARGO AREA (SECONDARY) VEHICLE COMPARTMENT HEATER KIT.....	0008 00
OPEN/CLOSE CAB DOORS AND WINDOWS.....	0009 00
ADJUST DRIVER'S SEAT.....	0010 00
RAISE/LOWER CAB PERSONNEL SEATS.....	0011 00
SET/RELEASE PARKING BRAKE (M548A3).....	0012 00
START ENGINE (M548A1).....	0013 00
START ENGINE (M548A3).....	0014 00
START ENGINE WITH EXTERNAL POWER.....	0015 00
START/DRIVE CARRIER WITH NO ELECTRICAL POWER OR WITH FAULTY TRANSMISSION SHIFT CONTROLLER (M548A3).....	0016 00
LOAD CARGO.....	0017 00
CHECK INSTRUMENT PANEL (M548A1).....	0018 00
CHECK INSTRUMENT PANEL (M548A3).....	0019 00
DRIVE CARRIER (M548A1).....	0020 00
DRIVE CARRIER (M548A3).....	0021 00
OPERATE TURN SIGNAL KIT.....	0022 00
STOP ENGINE (M548A1).....	0023 00
STOP ENGINE (M548A3).....	0024 00
FUEL CARRIER.....	0025 00
INSTALL/REMOVE AIR INTAKE AND EXHAUST GRILLE COVERS (M548A1).....	0026 00
INSTALL/REMOVE AIR INTAKE AND EXHAUST GRILLE COVERS (M548A3).....	0027 00
OPERATE AIR BRAKE KIT (M548A1).....	0028 00
OPERATE MATERIAL HANDLING KIT.....	0029 00
OPERATE WINCH (M548A1).....	0030 00
OPERATE VEHICLE COMPARTMENT AND CARGO HEATER.....	0031 00
OPERATE CARRIER LIGHTS.....	0032 00
OPERATE FIXED FIRE EXTINGUISHER SYSTEM.....	0033 00
OPERATE PORTABLE FIRE EXTINGUISHER.....	0034 00
MACHINE GUN MOUNTING KITS.....	0035 00
REMOVE/INSTALL POWER PLANT REAR ACCESS COVERS/DOOR AND PANEL.....	0036 00
RAISE/LOWER COMPARTMENT ACCESS DOOR (M548A3).....	0037 00
BLOCK/UNBLOCK CARRIER TRACKS.....	0038 00
OPERATE CARRIER IN EXTREME COLD: BELOW -25°F (-31°C).....	0039 00
OPERATE ENGINE COOLANT HEATER KIT (M548A1).....	0040 00

CHAPTER 2

OPERATOR INSTRUCTIONS

WORK PACKAGE INDEX (Continued)

<u>Title</u>	<u>Sequence No.</u>
OPERATE ENGINE COOLANT HEATER KIT (M548A3).....	.0041 00
PERFORM PRE-FORDING OPERATIONS.....	.0042 00
FORD WATER UP TO 40 INCHES DEEP.....	.0043 00
PERFORM POST-FORDING OPERATION.....	.0044 00
OPERATE CARRIER OVER ROUGH TERRAIN.....	.0045 00
OPERATE CARRIER IN EXTREME HEAT, HUMIDITY, OR SALTY CONDITIONS.....	.0046 00
BYPASS DEFECTIVE TRANSMISSION CONTROLLER (M548A3).....	.0047 00
CONNECT TOWED LOAD.....	.0048 00
TOWING DISABLED CARRIER (M548A1).....	.0049 00
TOWING DISABLED CARRIER (M548A3).....	.0050 00
TOW START DISABLED CARRIER (M548A1).....	.0051 00
TOW START DISABLED CARRIER (M548A3).....	.0052 00
OPERATE NBC AIR FILTER SYSTEM (M548A3).....	.0053 00

DESCRIPTION AND USE OF DRIVER'S CONTROLS AND INSTRUMENTS

0004 00

KNOW YOUR CONTROLS AND INSTRUMENTS

Before operating your carrier, make sure you know where all the controls and instruments are and how they work.

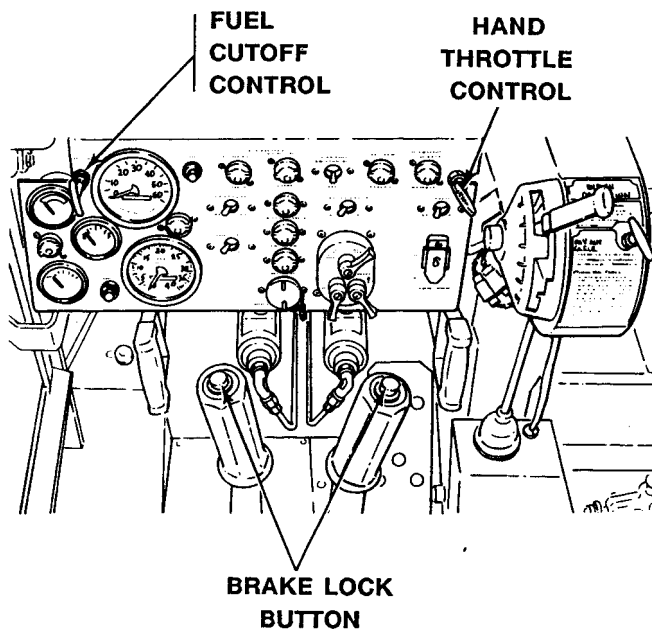

Table 1. DRIVER'S CONTROLS - M548A1

KEY	CONTROL OR INDICATOR	FUNCTION
	FUEL CUTOFF CONTROL	Starts and stops fuel flow to engine.
	HAND THROTTLE CONTROL	Allows engine speed to be controlled by hand.
	BRAKE LOCK BUTTON	Sets parking brakes.

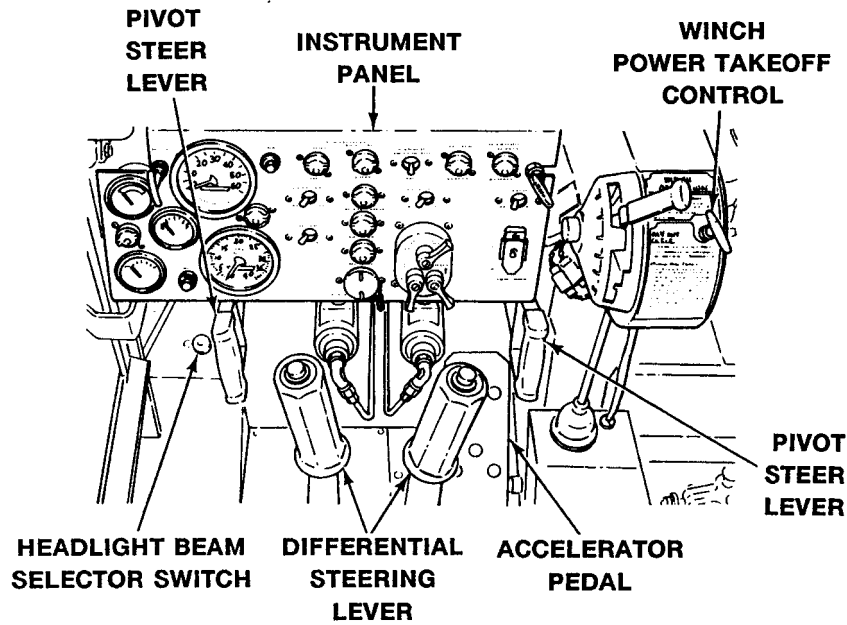

Table 2. DRIVER'S CONTROLS - M548A1 (Continued)

KEY	CONTROL OR INDICATOR	FUNCTION
	INSTRUMENT PANEL	Contains all gauges and indicators needed to operate the carrier.
	WINCH POWER TAKEOFF CONTROL	Engages power takeoff to operate carrier winch.
	ACCELERATOR PEDAL	Controls engine speed.
	PIVOT STEER LEVER	Used for quick turns at slow speed and steering carrier in water.
	DIFFERENTIAL STEERING LEVER	Used to steer carrier and apply parking brakes.
	HEADLIGHT BEAM SELECTOR SWITCH	Selects HI or LOW headlight beams.

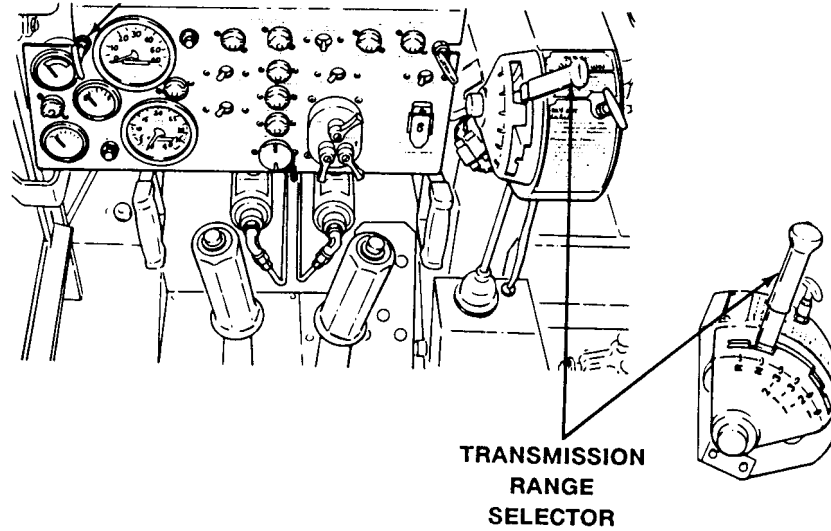

Table 3. DRIVER'S CONTROLS - M548A1 (Continued)

KEY	CONTROL OR INDICATOR	FUNCTION
	TRANSMISSION RANGE SELECTOR	Selects driving range of transmission.
	R (REVERSE) RANGE	Used for backing the carrier under all conditions.
	N (NEUTRAL) RANGE	Used when starting, idling, and operating the auxiliary equipment.
	2-3 RANGE	Used for high-speed driving on roads or level terrain when carrier is lightly loaded.
	1-3 RANGE	Used for normal driving on roads and level or rolling terrain. DO NOT DOWNSHIFT TO THIS RANGE ABOVE 40 MPH (64 KM/H).
	1-2 RANGE	Used for rough or soft terrain, going up or down long or moderately steep grades, and driving in water. DO NOT DOWNSHIFT TO THIS RANGE ABOVE 21 MPH (34 KM/H).
	1 RANGE	Used when going up or down steep grades and when entering or leaving water. DO NOT DOWNSHIFT TO THIS RANGE ABOVE 10 MPH (16 KM/H).

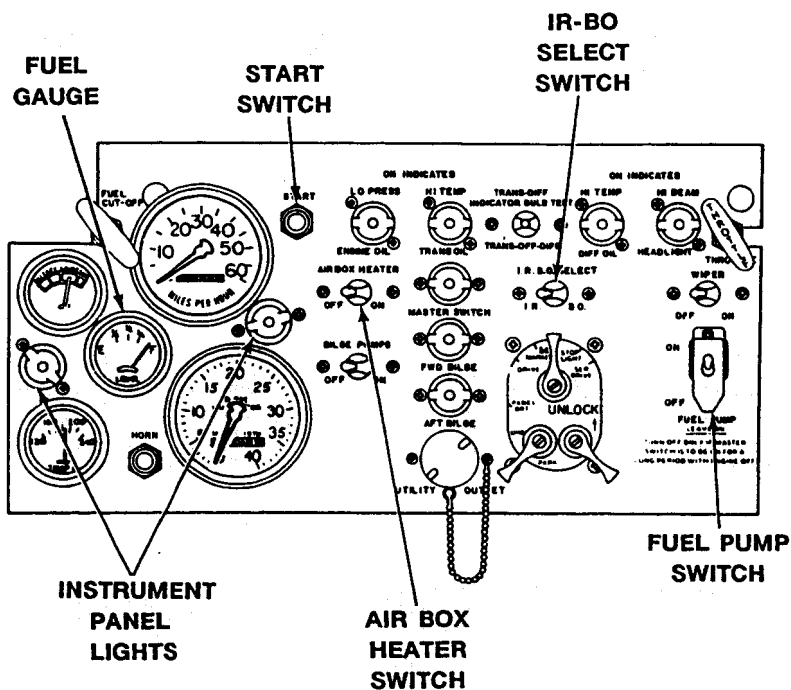

Table 4. DRIVER'S INSTRUMENT PANEL - M548A1

KEY	CONTROL OR INDICATOR	FUNCTION
	START SWITCH	Engages engine starter.
	IR-BO SELECT SWITCH	Two position toggle switch to select IR (infrared) or BO (blackout) mode of lights operation.
	FUEL PUMP SWITCH	Guarded switch allows fuel pump to be turned OFF if MASTER SWITCH will be on for a long period of time with the engine not running.
	AIR BOX HEATER SWITCH	Aids in starting engine when temperature is below 40°F (4.4°C).
	FUEL GAUGE	Indicates level of fuel in fuel tank.
	INSTRUMENT PANEL LIGHTS	Lights up gauges and indicators on instrument panel when panel lights are turned on.

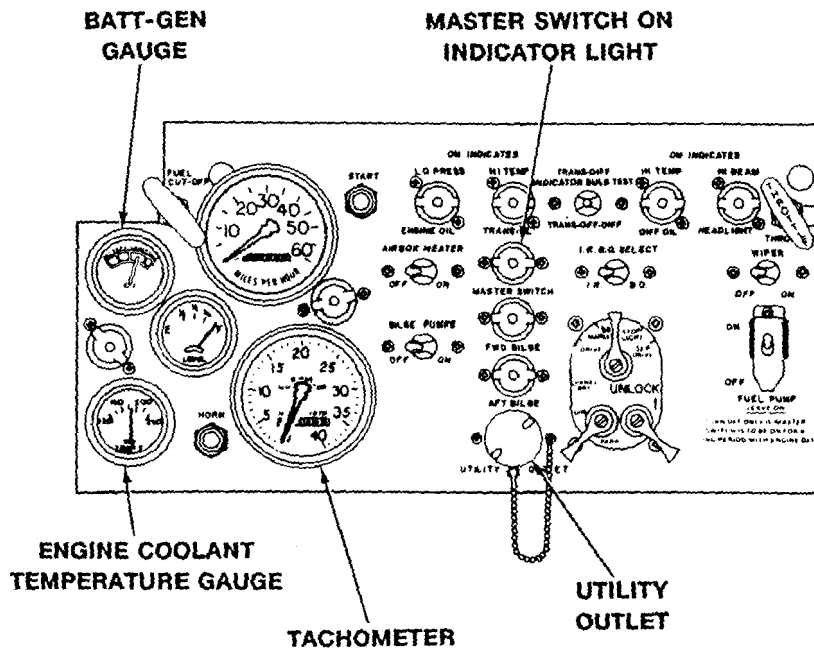

Table 5. DRIVER'S INSTRUMENT PANEL - M548A1 (Continued)

KEY	CONTROL OR INDICATOR	FUNCTION
	BATT GEN GAUGE	Indicates battery and generator condition.
	TACHOMETER	Indicates engine speed in revolutions per minute (RPM) and accumulated hours of engine operation.
	UTILITY OUTLET	Provides power for 24-volt accessories.
	MASTER SWITCH ON INDICATOR LIGHT	Light comes on when MASTER SWITCH is ON.
	ENGINE COOLANT TEMPERATURE GAUGE	Indicates engine operating temperature in degrees Fahrenheit.

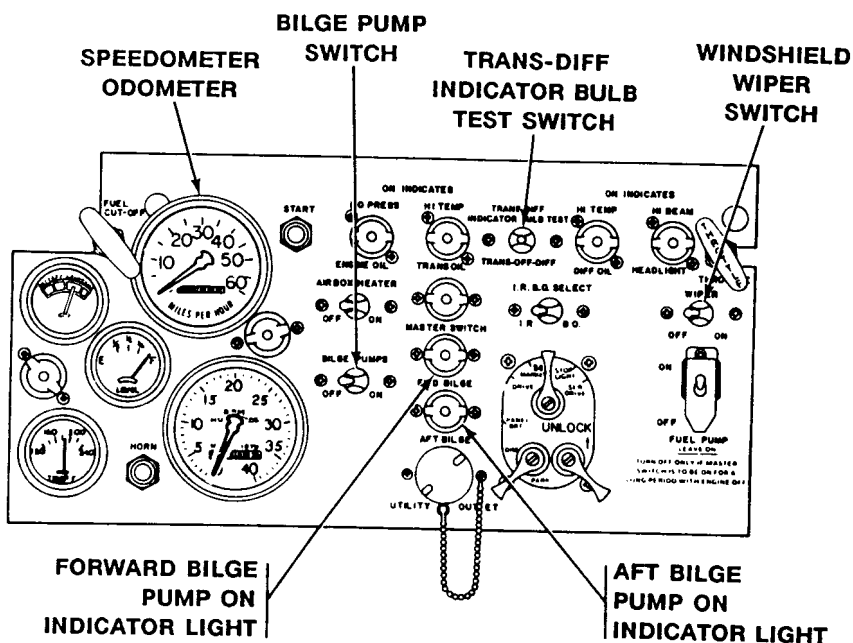

Table 6. DRIVER'S INSTRUMENT PANEL - M548A1 (Continued)

KEY	CONTROL OR INDICATOR	FUNCTION
	SPEEDOMETER/ODOMETER	Indicates carrier speed in miles per hour and total carrier distance traveled in miles.
	TRANS-DIFF INDICATOR BULB TEST SWITCH	Press to test check indicator light function.
	AFT BILGE PUMP ON INDICATOR LIGHT	Indicator light not used.
	FORWARD BILGE PUMP ON INDICATOR LIGHT	Indicator light comes ON when forward bilge pump is operating.
	BILGE PUMP SWITCH	Turns front bilge pump ON and OFF.
	WINDSHIELD WIPER SWITCH	Turns windshield wipers ON and OFF.

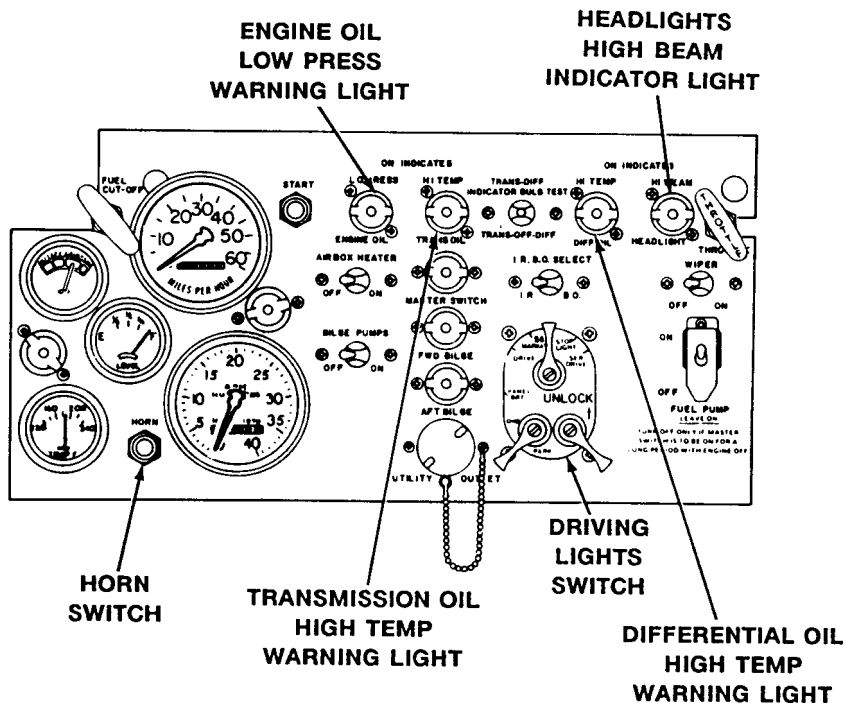

Table 7. DRIVER'S INSTRUMENT PANEL - M548A1 (Continued)

KEY	CONTROL OR INDICATOR	FUNCTION
	DIFFERENTIAL OIL HIGH TEMP WARNING LIGHT	Light comes on when coolant level is too low for safe operation.
	TRANS OIL HIGH TEMP WARNING LIGHT	Light comes on when transmission oil temperature is too high for safe operation.
	HORN SWITCH	Press switch to sound carrier horn.
	HEADLIGHTS HI BEAM INDICATOR LIGHT	Light comes on when headlight high beams are on.
	DRIVING LIGHTS SWITCH	Turns ON and OFF all exterior driving and instrument panel lights.

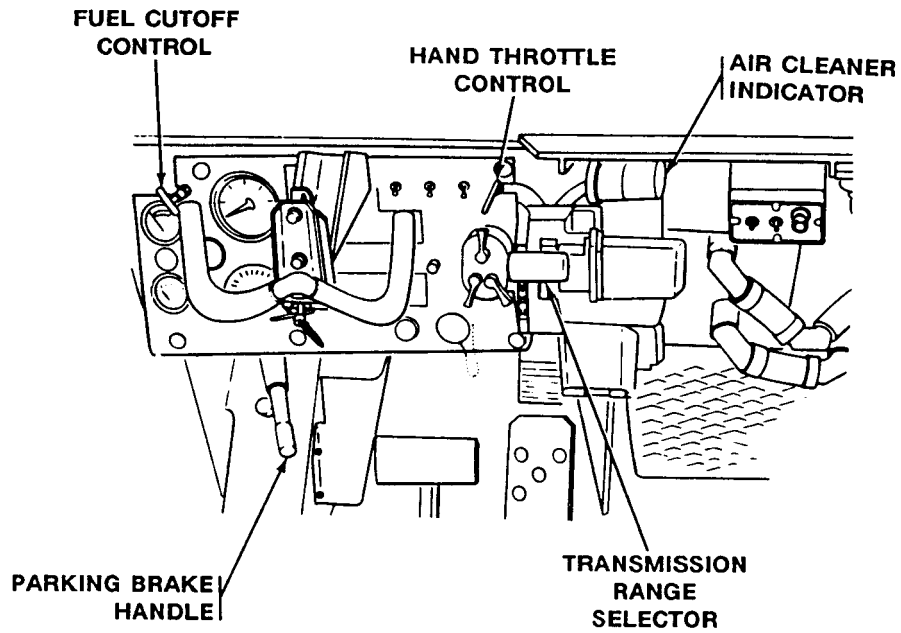

Table 8. DRIVER'S CONTROLS - M548A3

KEY	CONTROL OR INDICATOR	FUNCTION
	TRANSMISSION RANGE SELECTOR	Selects transmission range to suit your driving needs.
	FUEL CUTOFF CONTROL	Starts and stops fuel flow to engine.
	HAND THROTTLE CONTROL	Allows engine speed to be controlled by hand.
	PARKING BRAKE HANDLE	Sets parking brakes.
	AIR CLEANER INDICATOR	Indicates condition of air cleaner element.

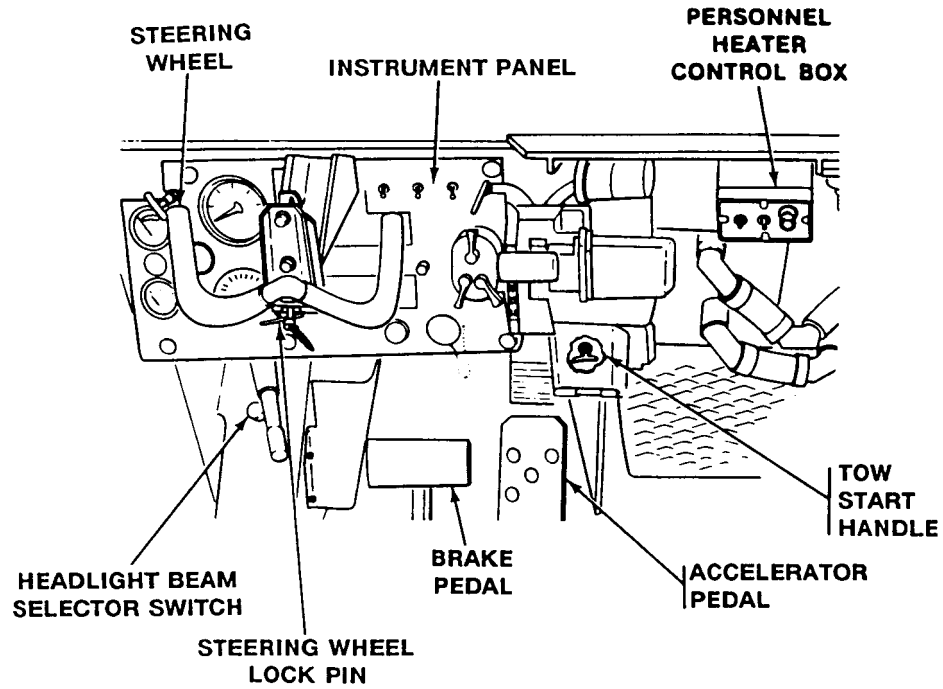

Table 9. DRIVER'S CONTROLS - M548A3 (Continued)

KEY	CONTROL OR INDICATOR	FUNCTION
	INSTRUMENT PANEL	Contains all gauges and indicators needed to operate the carrier.
	TOW START HANDLE	Locks transmission in gear to aid tow starting carrier.
	ACCELERATOR PEDAL	Controls engine speed.
	BRAKE PEDAL	Controls carrier brakes.
	STEERING WHEEL	Controls direction of carrier travel on land or water.
	STEERING WHEEL LOCK PIN	Locks steering wheel in center position.
	HEADLIGHT BEAM SELECTOR SWITCH	Selects HI or LOW headlight beams.

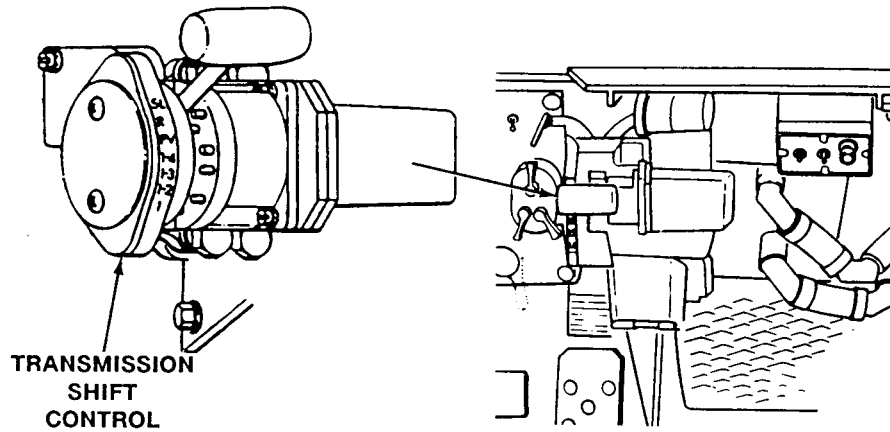

Table 10. DRIVER'S CONTROLS - M548A3 (Continued)

KEY	CONTROL OR INDICATOR	FUNCTION
	TRANSMISSION SHIFT CONTROLLER	<p>Selects driving RANGE of automatic transmission.</p> <p>RANGE 1 – Used when climbing or going down steep grades and when entering or leaving water; This range provides maximum traction, low speed maneuvering, and engine braking.</p> <p>RANGE 1-2 – Used when climbing or going down medium grades, driving cross country at slow speeds, and while in the water.</p> <p>RANGE 1-3 – Used when climbing or going down slight grades, driving cross country at high speeds, and driving on roads at moderate speeds.</p> <p>RANGE 1-4 – Used to drive carrier in normal forward operation.</p> <p>PV (PIVOT VEHICLE) POSITION - Used to turn carrier on its own center.</p> <p>R (REVERSE) POSITION – Used for backing the carrier on land or in the water.</p> <p>SL (STEERING LOCK) POSITION – Locks steering wheel in center position. Used during starting, idling and engine shut down.</p>

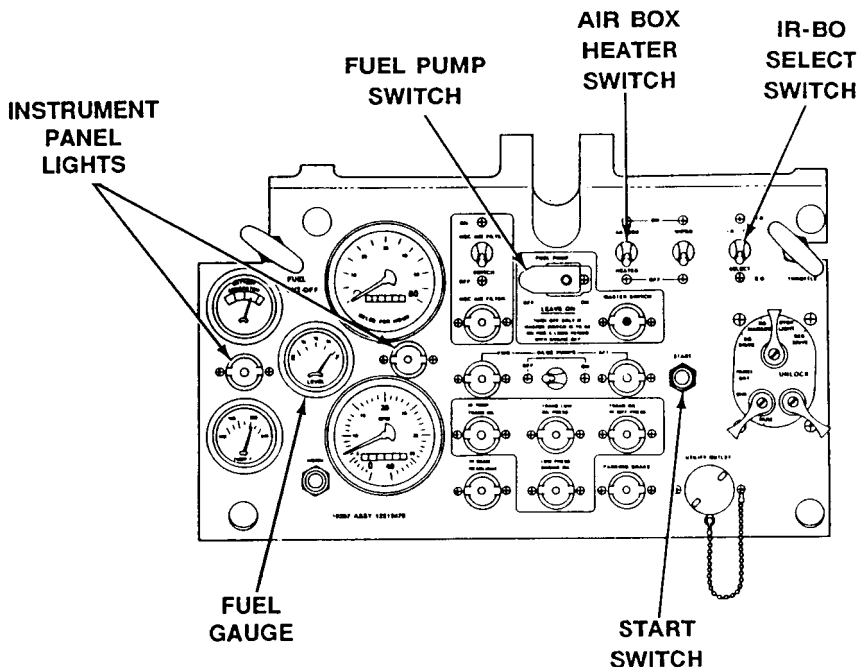

Table 11. DRIVER'S INSTRUMENT PANEL - M548A3

KEY	CONTROL OR INDICATOR	FUNCTION
	START SWITCH	Engages engine starter.
	IR-BO SELECT SWITCH	Two position toggle switch to select IR (infrared) or BO (blackout) mode of lights operation.
	FUEL PUMP SWITCH	Guarded switch allows fuel pump to be turned OFF if MASTER SWITCH will be on for a long period of time with the engine not running.
	AIR BOX HEATER SWITCH	Used while starting engine during cold weather -25°F to 40°F (-31°C to 4°C). Switch is spring loaded to the off position.
	FUEL GAUGE	Indicates level of fuel in fuel tank.
	INSTRUMENT PANEL LIGHTS	Lights up gauges and indicators on instrument panel when panel lights are turned on.

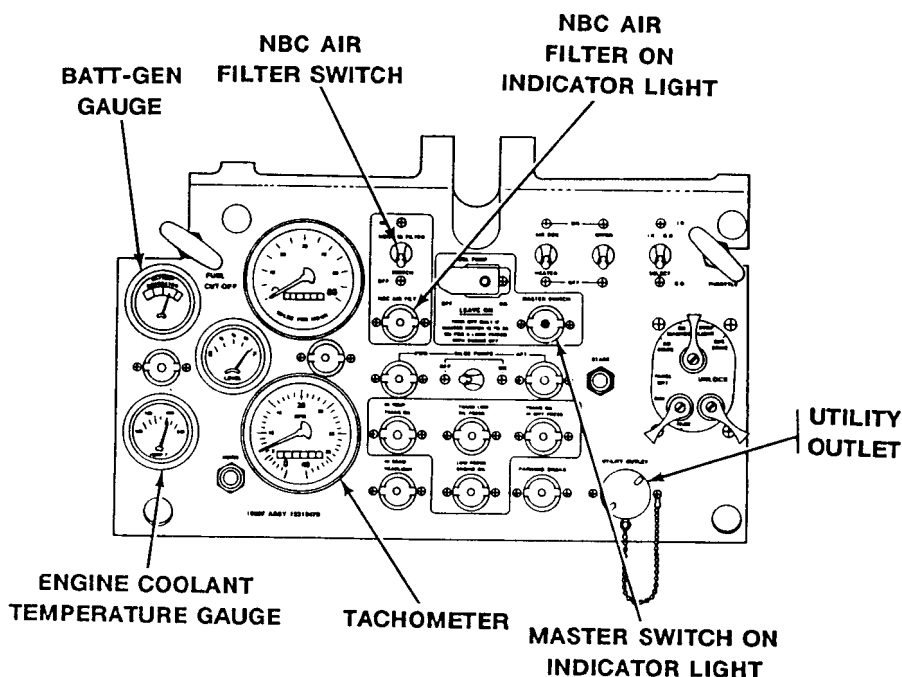

Table 12. DRIVER'S INSTRUMENT PANEL - M548A3 (Continued)

KEY	CONTROL OR INDICATOR	FUNCTION
	BATT GEN GAUGE	Indicates battery and generator condition.
	TACHOMETER	Indicates engine speed in revolutions per minute (RPM) and accumulated hours of engine operation.
	UTILITY OUTLET	Provides power for 24-volt accessories.
	MASTER SWITCH ON INDICATOR LIGHT	Light comes on when MASTER SWITCH is ON.
	ENGINE COOLANT TEMPERATURE GAUGE	Indicates engine operating temperature in degrees Fahrenheit.
	NBC AIR FILTER SWITCH	Applies power to operate NBC air filter system.
	NBC AIR FILTER ON INDICATOR LIGHT	Light comes on when NBC air filter switch is placed in ON position.

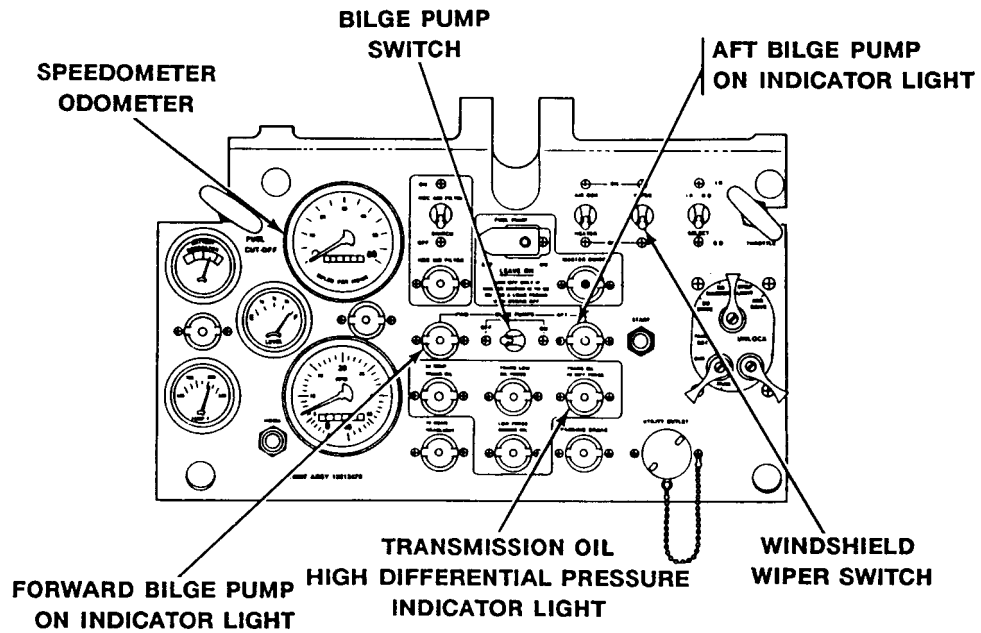

Table 13. DRIVER'S INSTRUMENT PANEL - M548A3 (Continued)

KEY	CONTROL OR INDICATOR	FUNCTION
	SPEEDOMETER/ODOMETER	Indicates carrier speed in miles per hour and total carrier distance traveled in miles.
	TRANSMISSION OIL HIGH DIFFERENTIAL PRESSURE INDICATOR LIGHT	Indicates transmission oil filter is clogged.
	AFT BILGE PUMP ON INDICATOR LIGHT	Carrier does not have an aft bilge pump.
	FORWARD BILGE PUMP ON INDICATOR LIGHT	Indicator light comes ON when forward bilge pump is operating.
	BILGE PUMP SWITCH	Turns front bilge pumps ON and OFF.
	WINDSHIELD WIPER SWITCH	Turns windshield wipers ON and OFF.

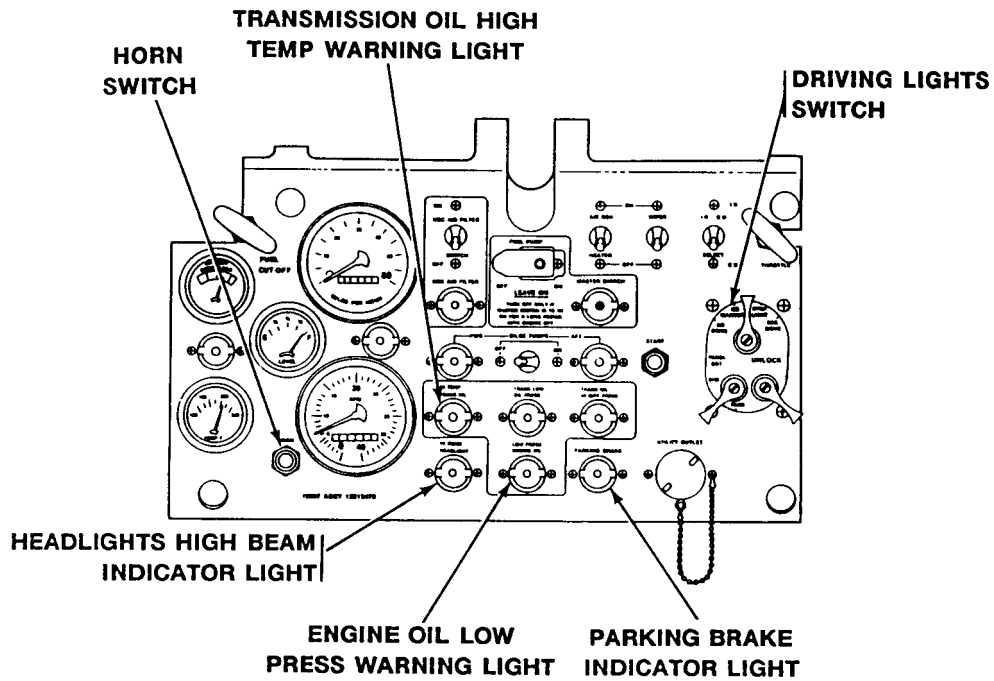

Table 14. DRIVER'S INSTRUMENT PANEL - M548A3 (Continued)

KEY	CONTROL OR INDICATOR	FUNCTION
	TRANS OIL HIGH TEMP WARNING LIGHT	Light comes on when transmission oil temperature is too high for safe operation.
	ENGINE OIL LOW PRESS WARNING LIGHT	Light comes on when oil pressure is too low for safe operation. Light should off 10 seconds after engine starts.
	HORN SWITCH	Press switch to sound carrier horn.
	HEADLIGHTS HIGH BEAM INDICATOR LIGHT	Light comes on when headlight high beams are on.
	DRIVING LIGHTS SWITCH	Turns ON and OFF all exterior driving and instrument panel lights.
	PARKING BRAKE INDICATOR LIGHT	Light comes on when parking brake is set.

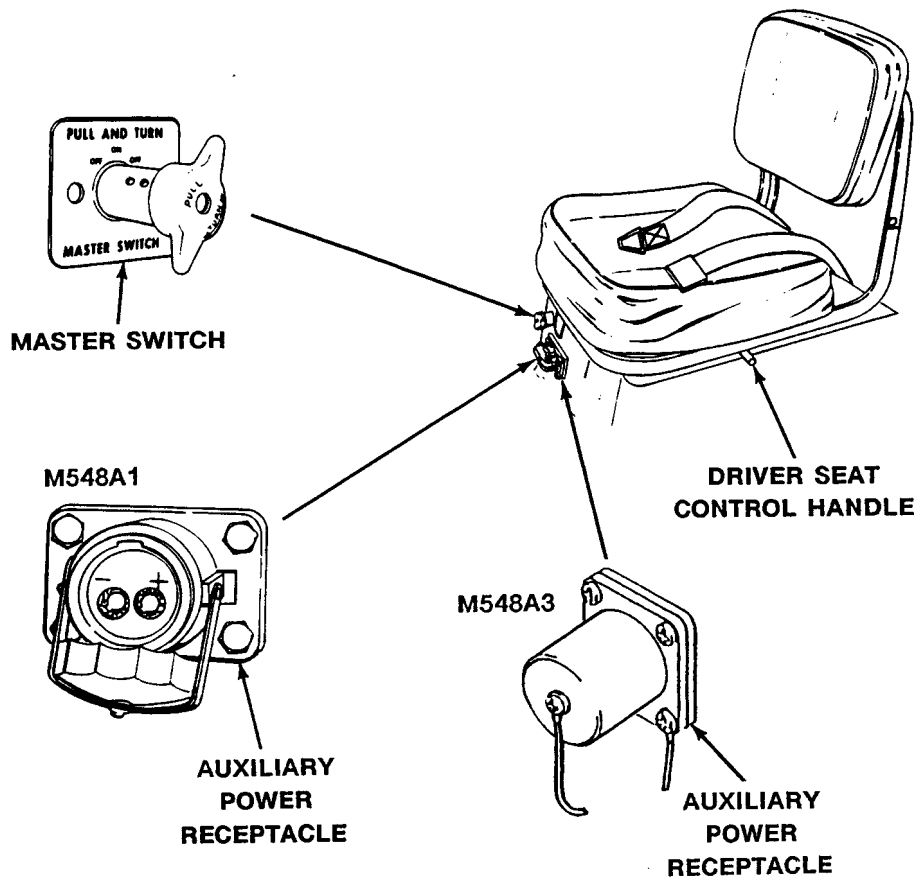

Table 15. DRIVER'S CONTROLS

KEY	CONTROL OR INDICATOR	FUNCTION
	MASTER SWITCH	Turns carrier electrical power ON or OFF.
	AUXILIARY POWER RECEPTACLE	Used with a slave cable to start carrier engine using an outside power source.
	DRIVER'S SEAT CONTROL HANDLE	Locks and releases driver's seat. Allows seat to be moved to the front or rear.

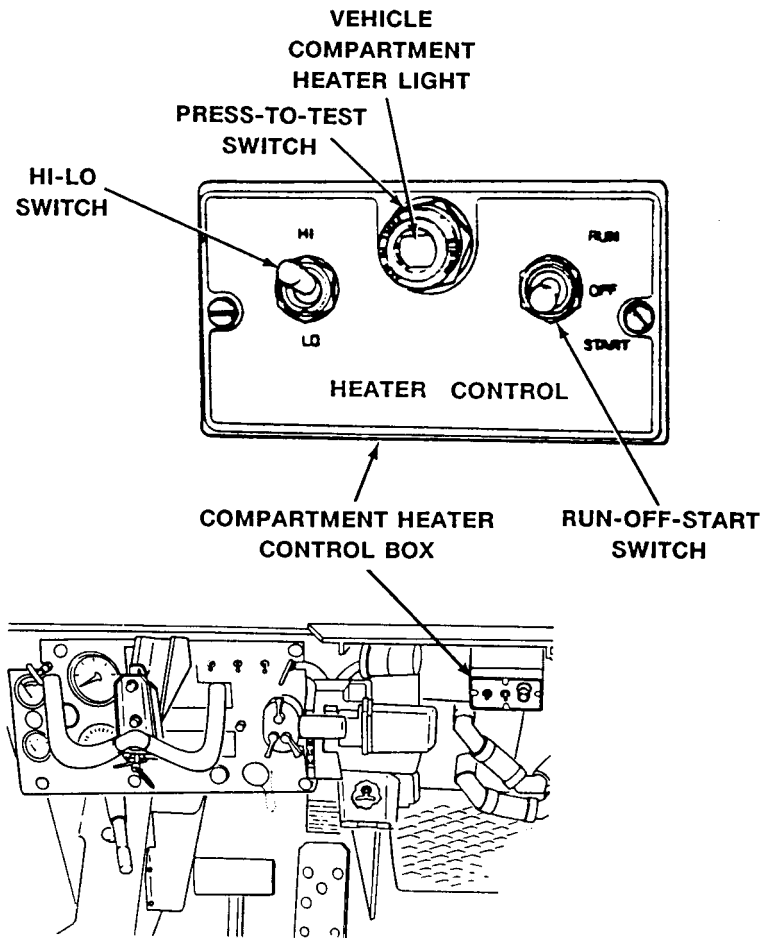

Table 16. COMPARTMENT HEATER CONTROL BOX

KEY	CONTROL OR INDICATOR	FUNCTION
	HI-LO SWITCH	Controls vehicle compartment heater output.
	RUN-OFF-START SWITCH	Controls operation of vehicle compartment heater.
	VEHICLE COMPARTMENT HEATER LIGHT	Indicates that vehicle compartment heater is ON.
	PRESS-TO-TEST SWITCH	Test VEHICLE COMPARTMENT HEATER light and control the incoming power.

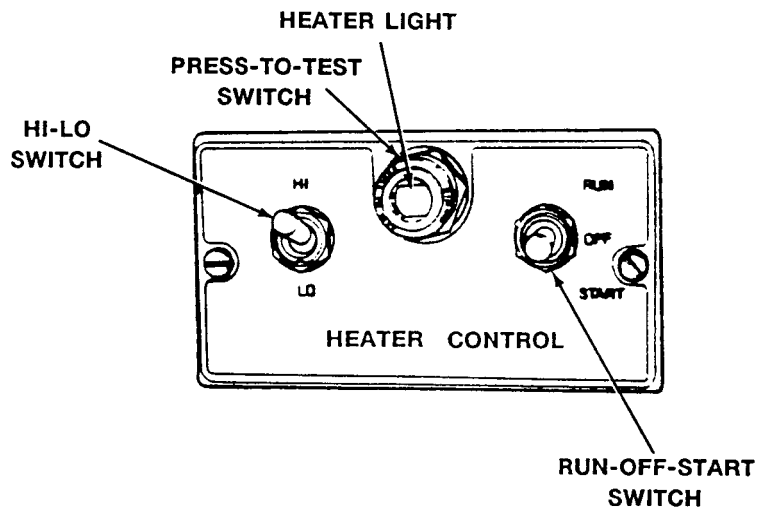

Table 17. ENGINE COOLANT HEATER CONTROL BOX

KEY	CONTROL OR INDICATOR	FUNCTION
	HI-LO SWITCH	Controls engine coolant heater output.
	COOLANT HEATER LIGHT	Controls operation of vehicle compartment heater.
	PRESS-TO-TEST SWITCH	When switch is pressed, light will come on if light bulb is good and if power is coming into the control box.
	RUN-OFF-START SWITCH	Controls operation of coolant heater.

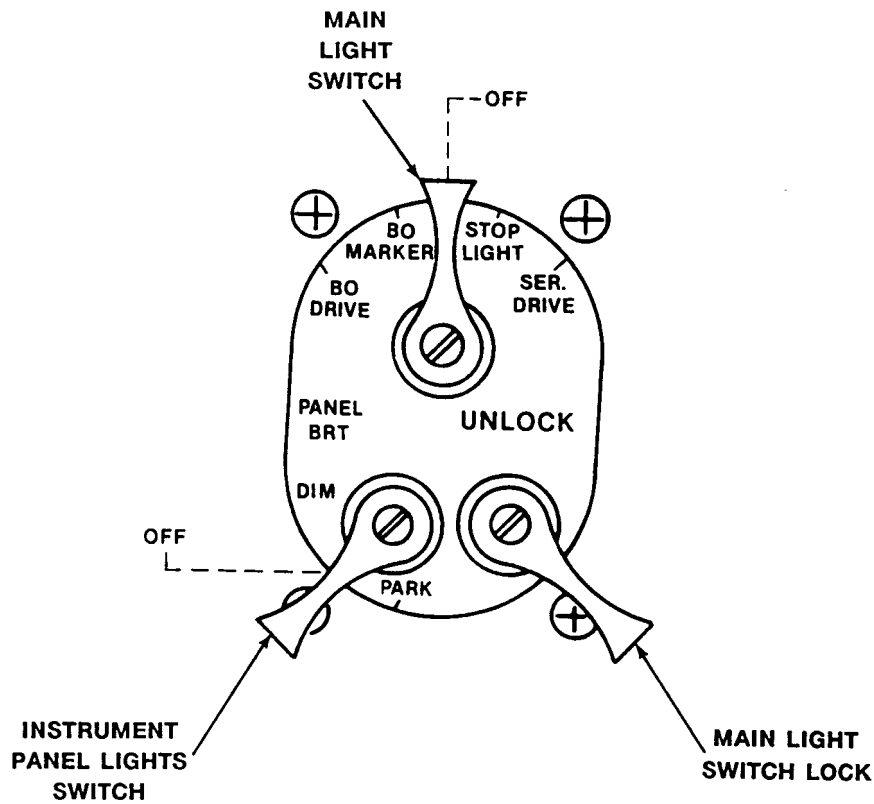
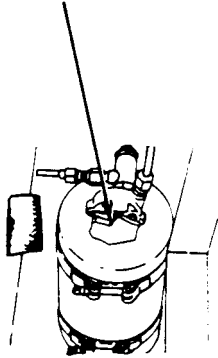

Table 18. DRIVER'S LIGHTS SWITCHES

KEY	CONTROL OR INDICATOR	FUNCTION
	MAIN LIGHT UNLOCK SWITCH	Unlocks driving light switch.
	MAIN LIGHT SWITCH	Controls outside carrier driving, stop-tail, and blackout lights.
	INSTRUMENT PANEL LIGHTS SWITCH	Controls carrier panel and parking lights.

**INSIDE
FIRE EXTINGUISHER
KNOB**



**INSIDE
FIRE EXTINGUISHER
PULL HANDLE**

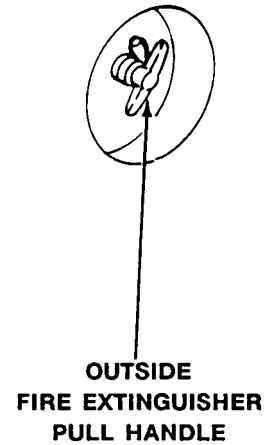
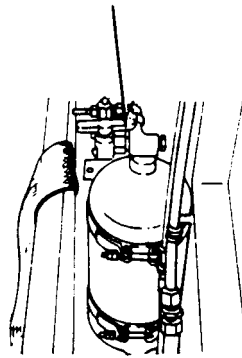

NOTE

Located at left rear of driver's seat. Used for fire in power plant compartment.

Table 19. FIXED FIRE EXTINGUISHER SYSTEM

KEY	CONTROL OR INDICATOR	FUNCTION
	OUTSIDE FIRE EXTINGUISHER PULL HANDLE	Discharges fixed fire extinguisher manually from outside carrier.
	INSIDE FIRE EXTINGUISHER KNOB	Discharges fixed fire extinguisher manually from inside carrier.
	INSIDE FIRE EXTINGUISHER PULL HANDLE	Discharges fixed fire extinguisher manually from inside carrier.

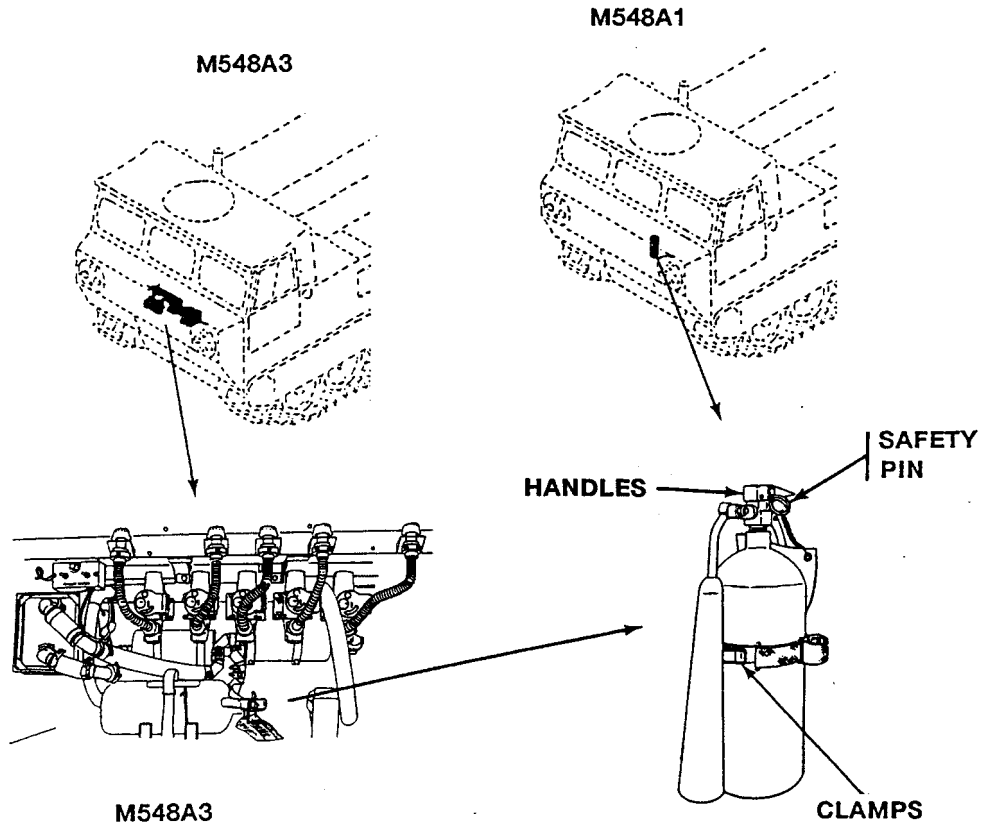

NOTE

On M548A1, the portable fire extinguisher is located below the dash to the right of the driver. On M548A3, the portable fire extinguisher is located below the NBC equipment in the crew compartment.

Table 20. PORTABLE FIRE EXTINGUISHER SYSTEM

KEY	CONTROL OR INDICATOR	FUNCTION
	CLAMPS	Hold portable fire extinguisher in place under dash.
	SAFETY PIN	Keep fire extinguisher from accidentally discharging while stowed.
	HANDLES	Discharges fire extinguisher when squeezed together.

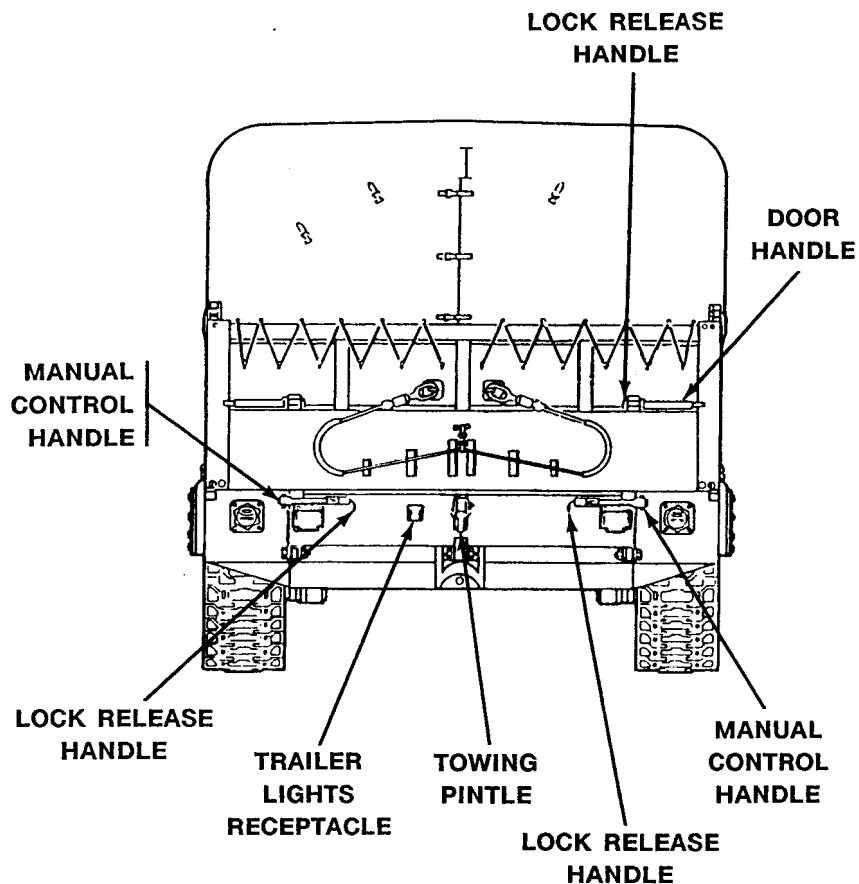

Table 21. CARGO COMPARTMENT DOOR AND TAILGATE CONTROLS

KEY	CONTROL OR INDICATOR	FUNCTION
	TOWING PINTLE LOCK-RELEASE LEVER MANUAL CONTROL HANDLE TRAILER LIGHTS RECEPTACLE DOOR HANDLE	Used to tow a disabled vehicle short distances, or a trailer. Locks tailgate and cargo compartment door in raised position. Locks tailgate in raised position and unlocks tailgate for opening. Provides a connection for trailer turn signal and warning lights. Locks cargo compartment door in closed position and unlocks cargo compartment door for opening.

OPEN/CLOSE CARGO COMPARTMENT DOOR AND TAILGATE

0005 00

THIS WORK PACKAGE COVERS:

- Open Cargo Compartment Door (page 0005 00-2).
- Close Cargo Compartment Door (page 0005 00-3).
- Open Tailgate (page 0005 00-4).
- Close Tailgate (page 0005 00-5).

INITIAL SETUP:

Maintenance Level

Operator

Personnel Required

Soldier

Equipment Condition

Carrier stopped
Carrier blocked (WP 0038 00)

OPEN CARGO COMPARTMENT DOOR

CAUTION

Driving carrier with open cargo compartment door can cause cracks in cargo compartment side walls. Ensure cargo compartment door is closed before driving carrier.

NOTE

Cargo compartment door is opened from the right side.

1. Pull lock-release handle and push door handle up until locking pins clear top and bottom brackets.
2. Pull door open and swing it around until it stops against left side of carrier.
3. Secure door using web strap.

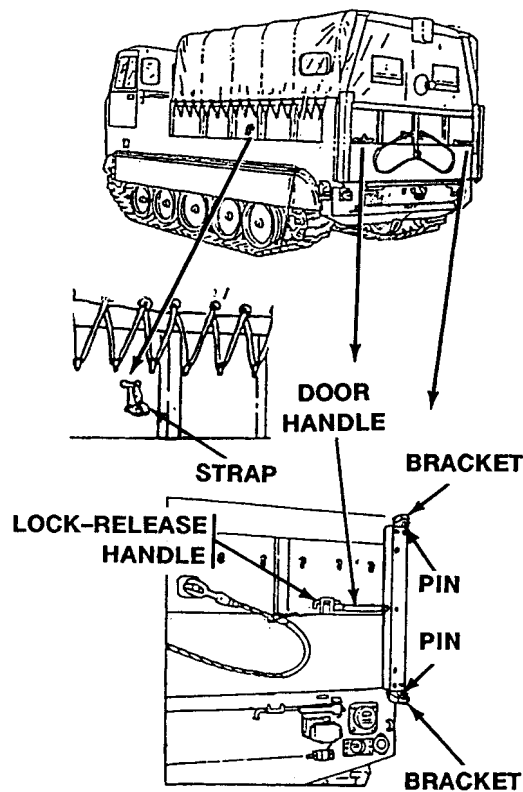

CLOSE CARGO COMPARTMENT DOOR

1. Remove web strap securing door and swing door around to rear of carrier.
2. Push door handle up until locking pins clear top and bottom brackets, pull lock-release handle, and close door. Release handles.

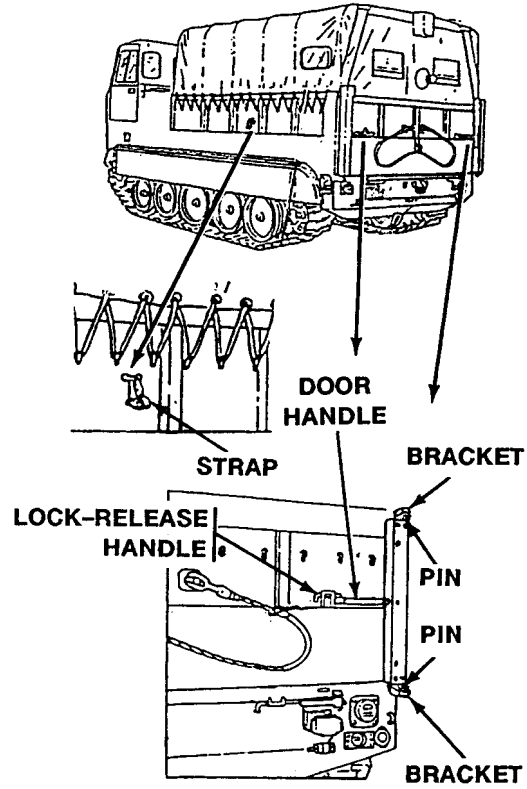

OPEN TAILGATE

WARNING



Tailgate is heavy. Personnel can be injured and equipment damaged. Open and lower tailgate slowly. Avoid being caught between tailgate and hull or ground.

1. Pull lock-release levers toward carrier center and pull manual control handles outboard. Lower tailgate slowly until open.

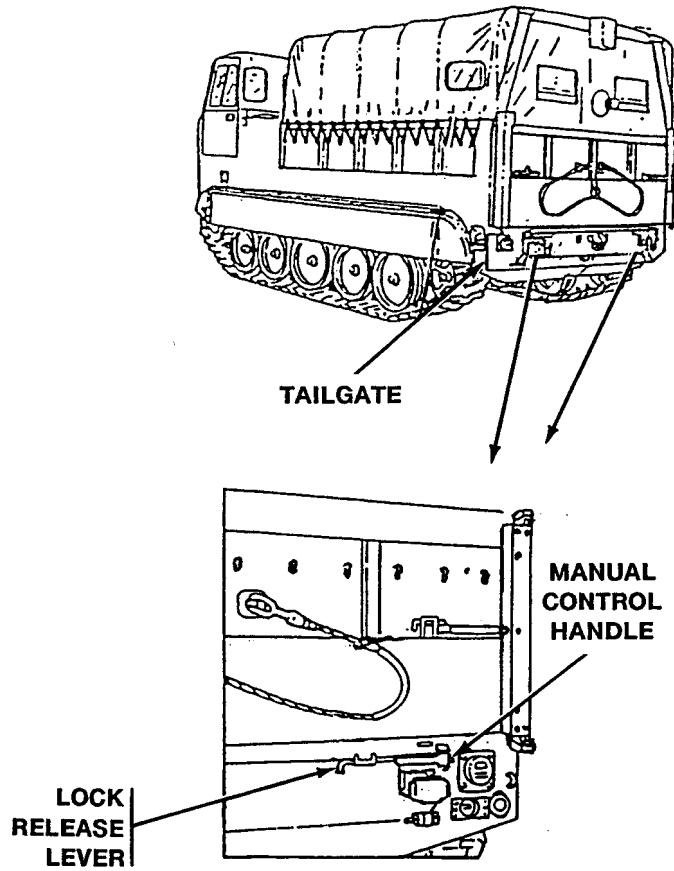

CLOSE TAILGATE

1. Raise tailgate until closed and push manual control handles inboard. Ensure lock-release levers engage manual control handles.

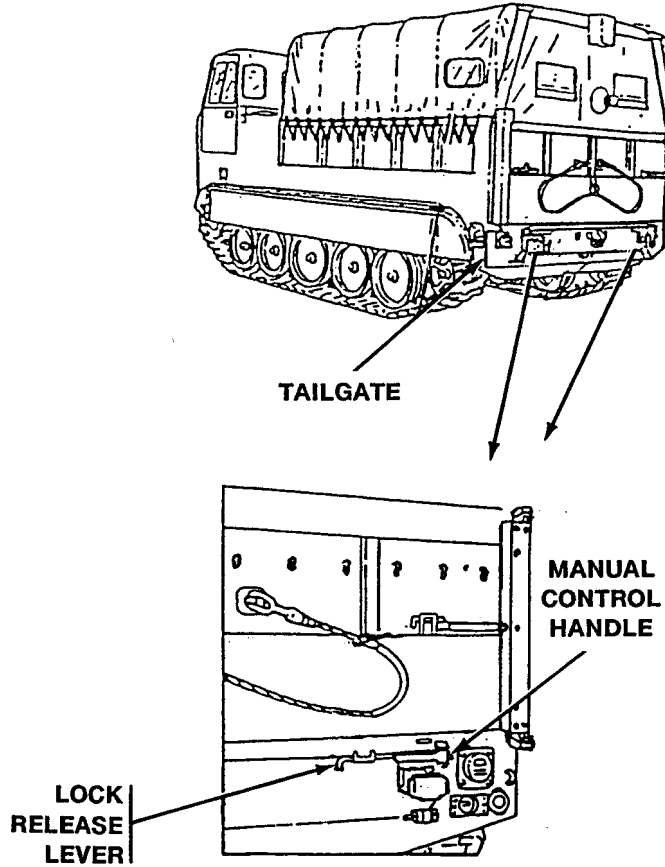

END OF TASK

REMOVE/INSTALL TOP ACCESS COVER AND GRILLES (M548A3)

0006 00

THIS WORK PACKAGE COVERS:

Removal (page 0006 00-1).
 Installation (page 0006 00-1).

INITIAL SETUP:

Maintenance Level

Operator

Equipment Condition

Engine stopped (WP 0024 00)
 Carrier blocked (WP 0038 00)

Personnel Required

Soldier

REMOVAL

1. Loosen four T-handles.
2. Turn four clamps and remove access cover and two grilles from carrier.

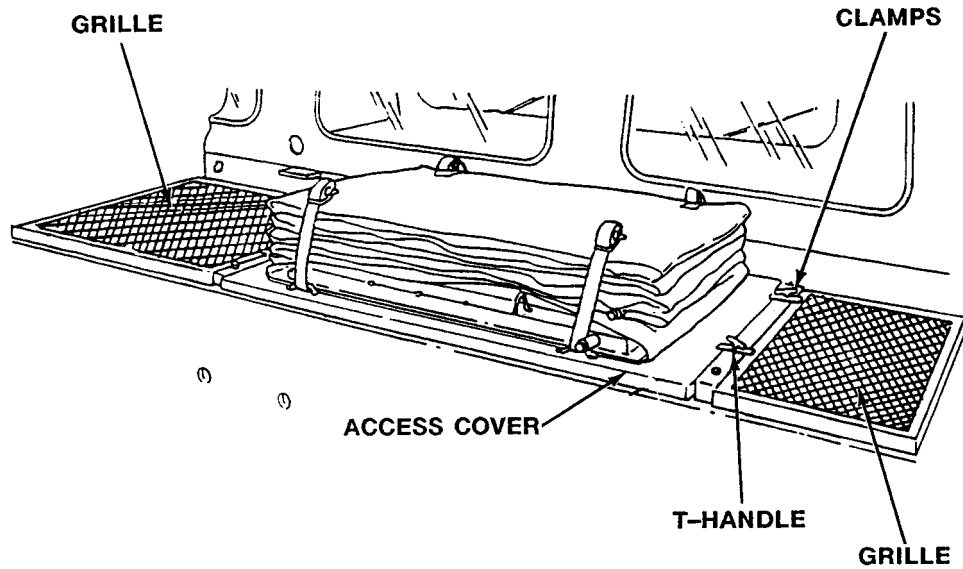

INSTALLATION

1. Install two grilles and access cover on hull with four clamps.
2. Tighten four T-handles.

END OF TASK

REMOVE/INSTALL CARGO COMPARTMENT FLOOR PLATES

0007 00

THIS WORK PACKAGE COVERS:

Removal (page 0007 00-1).
 Installation (page 0007 00-3).

INITIAL SETUP:

Maintenance Level

Operator

Personnel Required

Driver (2)

Tools and Special Tools

Socket Wrench Handle (WP 0081 00, Item 27)
 Socket Wrench, 9/16 inch (WP 0081 00, Item 38)

Equipment Condition

Engine stopped (WP 0023 00), (WP 0024 00)
 Carrier blocked (WP 0038 00)

REMOVAL

NOTE

Cargo compartment floor plates are used in two positions. In high position, floor plates are placed even with sponsons for a wide floor. In low position, floor plates are placed down between sponsons to allow room for high loads or provide leg room for crew members. Stow rear lifting eyes under floor plates on hull crossmember.

If installed, remove rear engine access panel (WP 0036 00) and plywood protector (WP 0078 00).

1. Start removing floor plates from front or back end of cargo area. Remove one end floor plate first. Remove 14 screws and spacers. Lift out floor plate. Use socket handle and socket.

CAUTION

Notify unit maintenance to replace lifting eyes on sponson. The lifting eyes screws must be torqued so they do not fail when carrier is lifted.

2. Remove eight screws and take lifting eyes from sponson. Move lifting eyes to hull crossmember, and secure with screws. Use socket handle and socket.

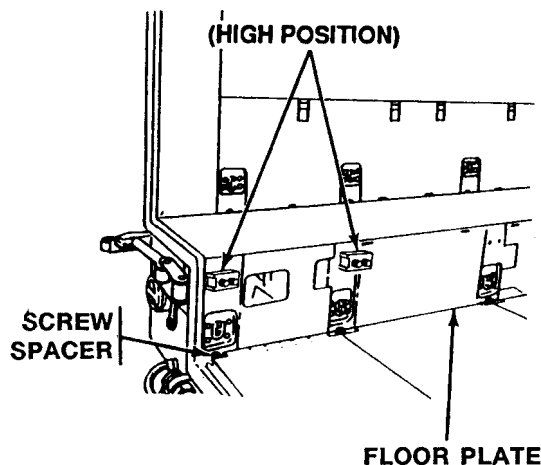

3. Remove 28 screws and washers that hold 14 floor plate support brackets. Use socket handle and socket.

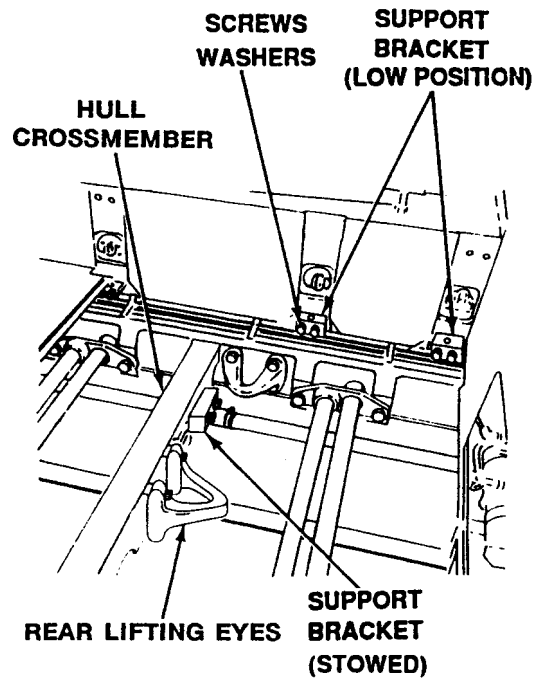

INSTALLATION**NOTE**

For the high floor position, install seven support brackets on each sponson. For the low floor position, install four support brackets along the front of each sponson. Stow the other six support brackets on the hull crossmember.

1. Move floor plate support brackets to new positions and secure brackets with washers and screws. Use socket handle and socket.
2. Position floor plates on floor plate support brackets secure floor plates with 14 spacers and screws. Use socket handle and socket.

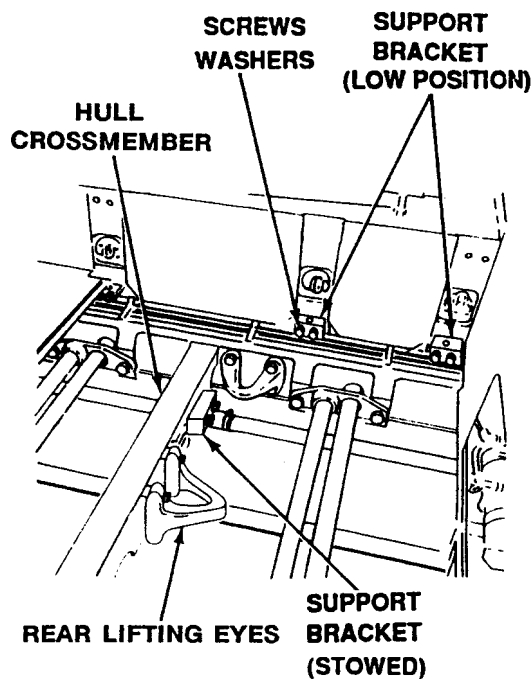

3. Install rear engine access panel. See task: REMOVE/INSTALL POWER PLANT REAR ACCESS COVERS/DOOR AND PANEL (WP 0036 00).
4. Install plywood protector, if removed. See task: REMOVE/INSTALL BULKHEAD PROTECTOR (WP 0078 00).

END OF TASK

**OPEN/CLOSE CARGO AREA (SECONDARY) VEHICLE COMPARTMENT
HEATER KIT**

0008 00

THIS WORK PACKAGE COVERS:

- Open Rear Curtain (page 0008 00-2).
- Close Rear Curtain (page 0008 00-3).
- Open Ventilation Curtain (page 0008 00-4).
- Close Ventilation Curtain (page 0008 00-5).
- Open Window Curtain (page 0008 00-6).
- Close Window Curtain (page 0008 00-7).

INITIAL SETUP:

Maintenance Level

Operator

Equipment Condition

Carrier stopped

Personnel Required

Soldier

OPEN REAR CURTAIN

1. Unbuckle four straps from buckles.
2. Pull hook and pile fastener tape on side and bottom of curtain.
3. Roll curtain to top of cargo opening.
4. Secure rolled curtain to insulated cargo cover with three buckles and long straps.

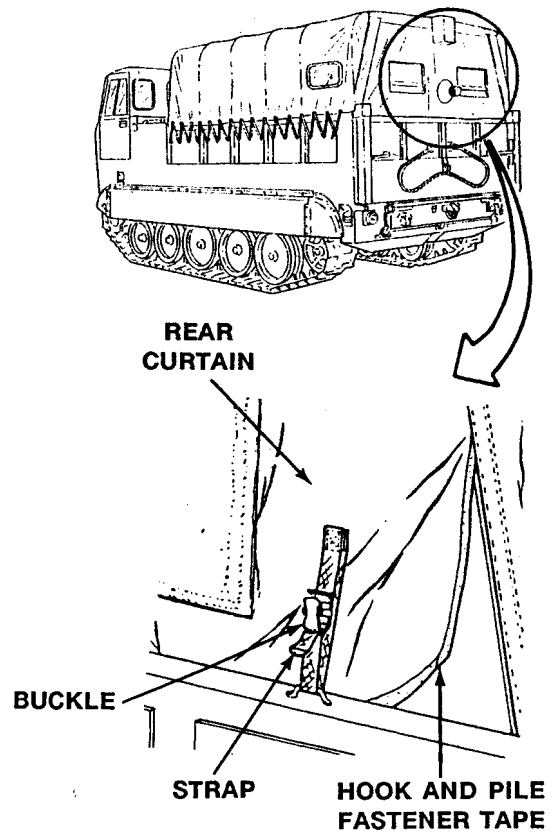

CLOSE REAR CURTAIN

1. Unbuckle three straps from buckles securing rolled curtain to insulated cargo cover.
2. Roll curtain down and secure to cargo compartment door with four buckles and straps.
3. Press hook and pile fastener tape together on side and bottom of curtain.

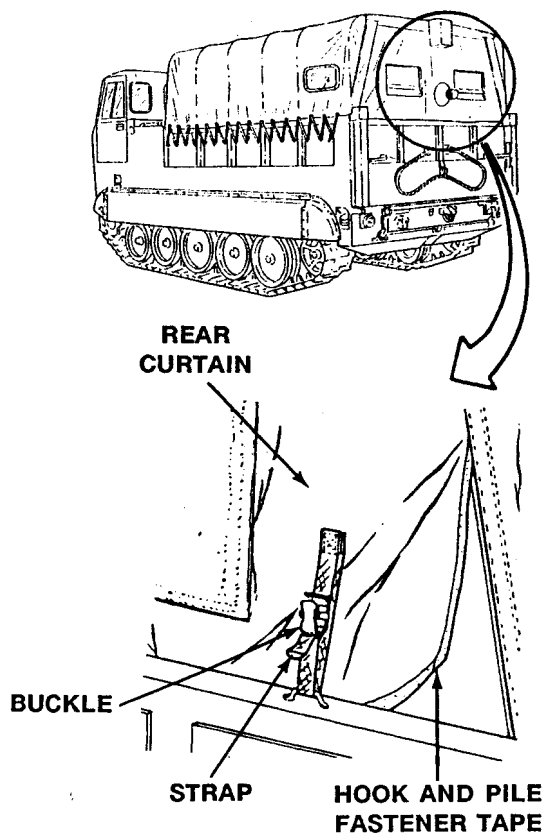

OPEN VENTILATION CURTAIN

NOTE

Two ventilation curtains cover openings in the rear curtain.

1. Pull hook and pile fastener tape on side and bottom of ventilation curtain.
2. Raise ventilation curtain and wedge between rear curtain and rear support bow.

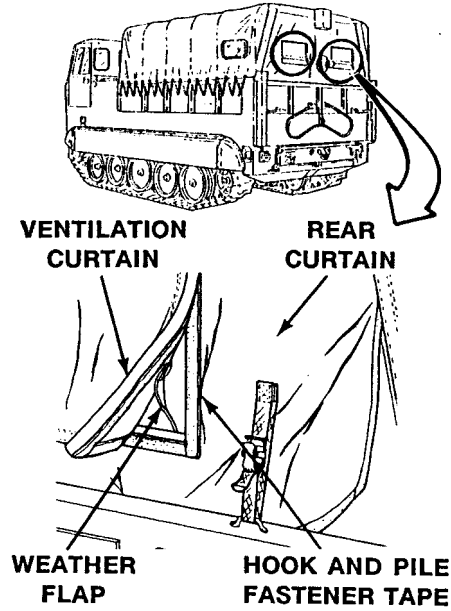

CLOSE VENTILATION CURTAIN

1. Lower curtain ensuring that weather flap goes through opening in rear curtain.
2. Press hook and pile fastener tape together on side and bottom of ventilation curtain.

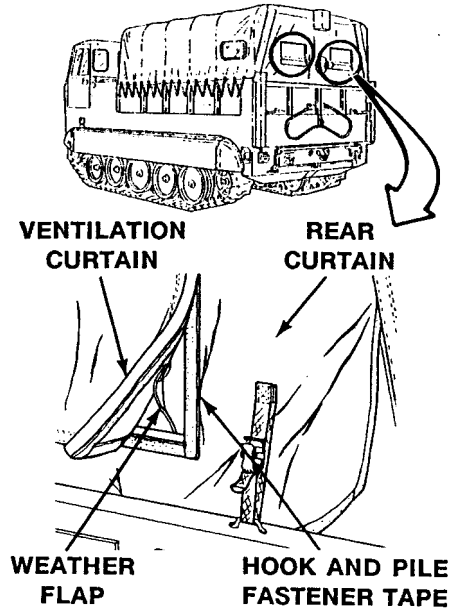

OPEN WINDOW CURTAIN**NOTE**

Cloth curtains inside insulated cargo cover can be used to cover three thermal windows.

1. Untie three lower ties and roll up window curtain.
2. Secure window curtain with three upper ties.

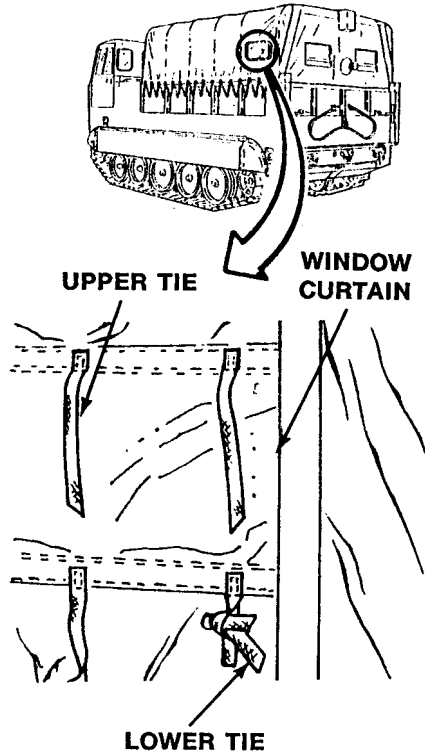

CLOSE WINDOW CURTAIN

1. Untie three upper ties and roll down window curtain.
2. Secure window curtain with three lower ties.

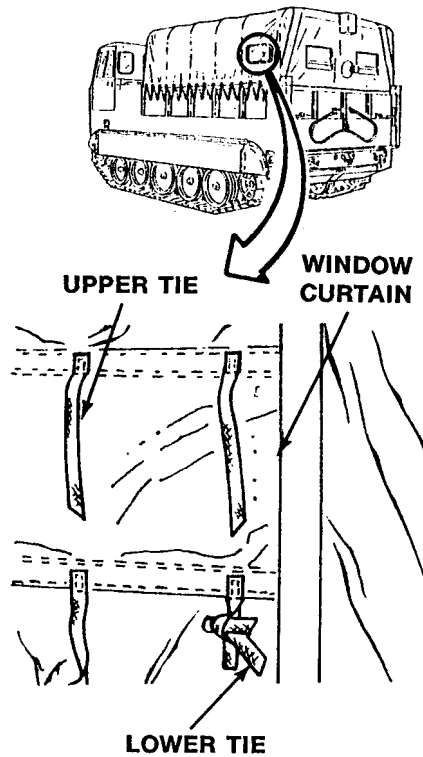
**END OF TASK**

OPEN/CLOSE CAB DOORS AND WINDOWS

0009 00

THIS WORK PACKAGE COVERS:

- Open cab doors (page 0009 00-1).
- Close cab doors (page 0009 00-2).
- Windows (page 0009 00-2).

INITIAL SETUP:

Maintenance Level

Operator

Equipment Condition

Carrier stopped

Personnel Required

Driver or soldier

OPEN CAB DOORS

1. To open the door from the outside, pull the handle outward. The latch will release and the door will open. The latch catches automatically when you close the door.
2. To open the door from the inside, pull on the latch chain and push the door open.

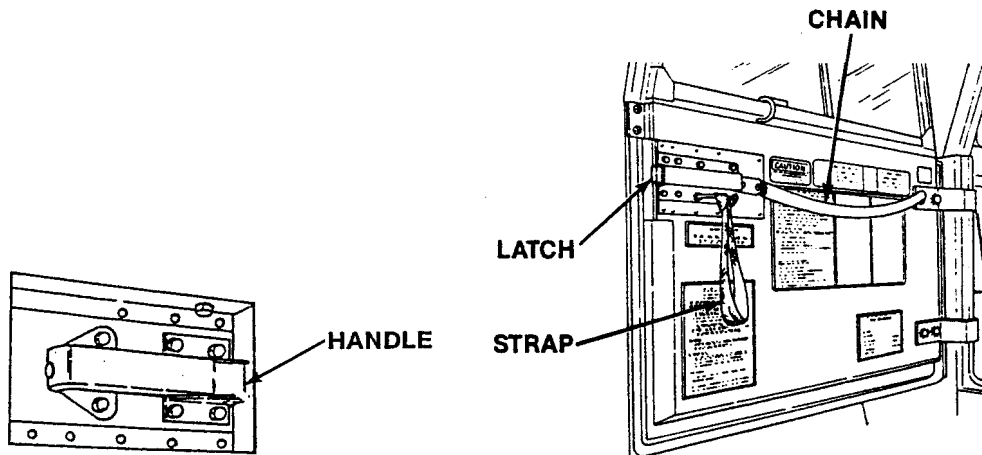

CLOSE CAB DOORS

1. To close the door from the inside, pull on the web strap. The latch will catch automatically when you close the door.

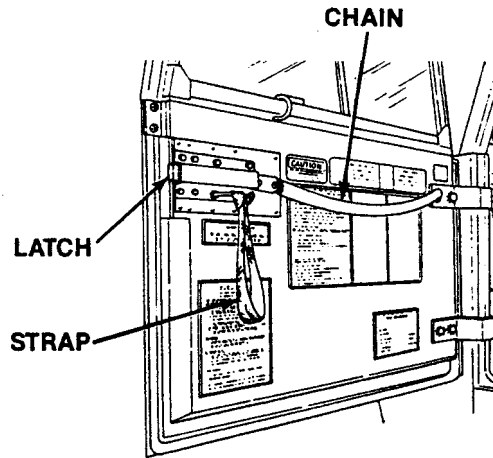
**WINDOWS**

1. The rear section of each side window slides forward. Pull up on the window control and move the window to where you want it. Four holes in the bottom window frame let you secure the window in full-open, full-closed, or two partly open positions.

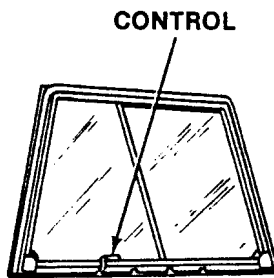
**END OF TASK**

ADJUST DRIVER'S SEAT

0010 00

THIS WORK PACKAGE COVERS:

Adjust Driver's Seat (page 0010 00-1).

INITIAL SETUP:

Maintenance Level

Operator

Equipment Condition

Engine stopped (WP 0023 00), (WP 0024 00)

Personnel Required

Driver

ADJUST DRIVER'S SEAT

WARNING

Seat fore/aft lock may not always latch. You could be injured. After adjusting seat, apply fore/aft action to be sure seat is locked in position and you have your seat belt on.

1. While sitting in driver's seat, pull forward on seat control. Slide the seat to where you want it and then let go of seat control.
2. The control will lock the seat in any one of five positions. If the control does not catch when you let it go, slide the seat back and forth slightly.

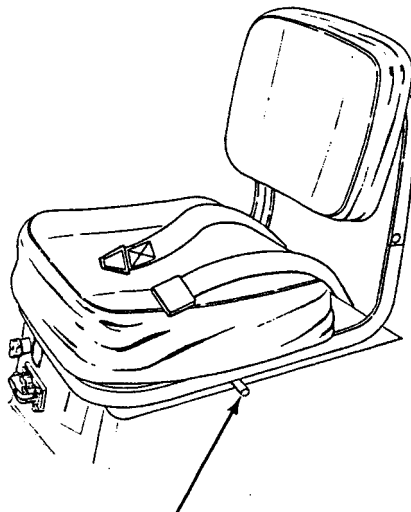

**CONTROL:
PULL FORWARD
TO RELEASE**

END OF TASK

RAISE/LOWER CAB PERSONNEL SEATS

0011 00

THIS WORK PACKAGE COVERS:

- Raise Center Seat (page 0011 00-1).
- Lower Center Seat (page 0011 00-2).
- Raise Driver's Seat (page 0011 00-2).
- Lower Driver's Seat (page 0011 00-3).

INITIAL SETUP:

Maintenance Level

Operator

Equipment Condition

Engine stopped (WP 0023 00), (WP 0024 00)
Carrier blocked (WP 0038 00)

Personnel Required

Driver
Soldier

RAISE CENTER SEAT

1. Tip center seat(s) back and secure with web strap.

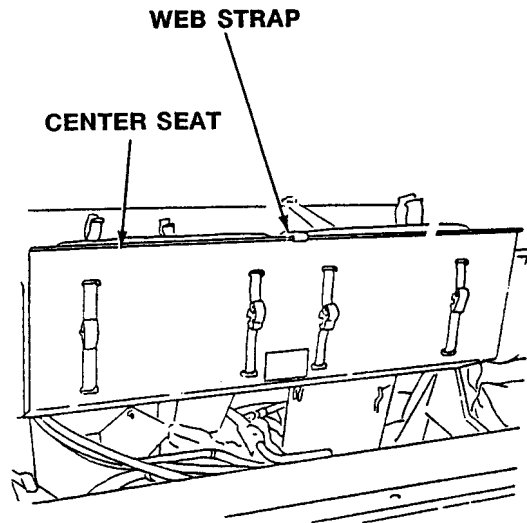

LOWER CENTER SEAT

1. Release web strap and lower center seat(s) to normal position.

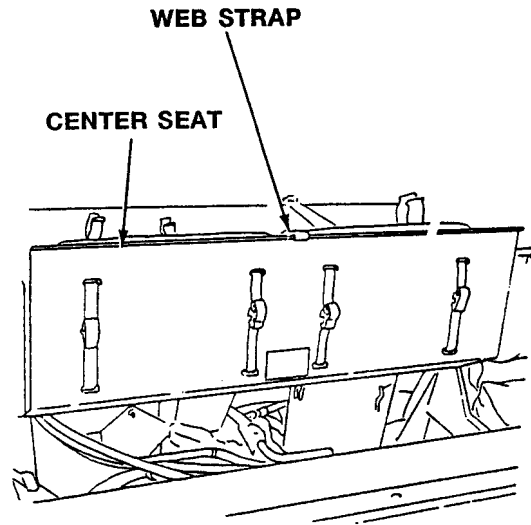
**RAISE DRIVER'S SEAT**

1. Remove T-bolt behind driver's seat and tip seat forward.

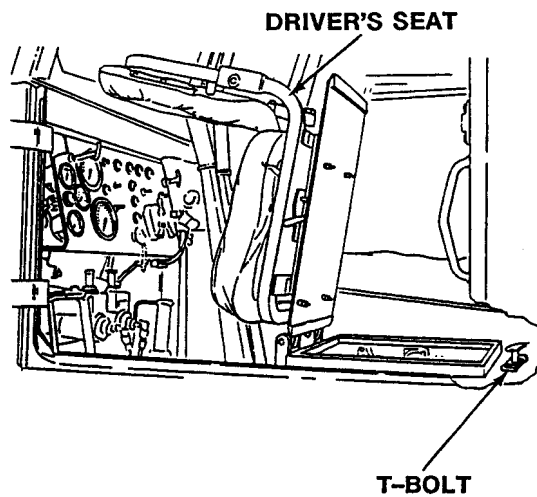

LOWER DRIVER'S SEAT

1. Lower driver's seat to normal position and install T-bolt behind driver's seat.

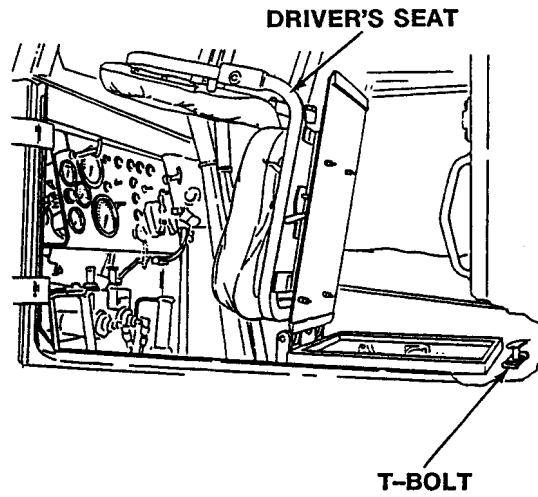
**END OF TASK**

SET/RELEASE PARKING BRAKE (M548A3)

0012 00

THIS WORK PACKAGE COVERS:

- Set (page 0012 00-1).
- Release (page 0012 00-1).
- Adjust (page 0012 00-2).

INITIAL SETUP:

Maintenance Level

Operator

Equipment Condition

Carrier stopped

Personnel Required

Driver

SET

1. Depress and hold brake pedal.
2. Pull up on parking brake handle to set parking brake.
3. Release brake pedal.

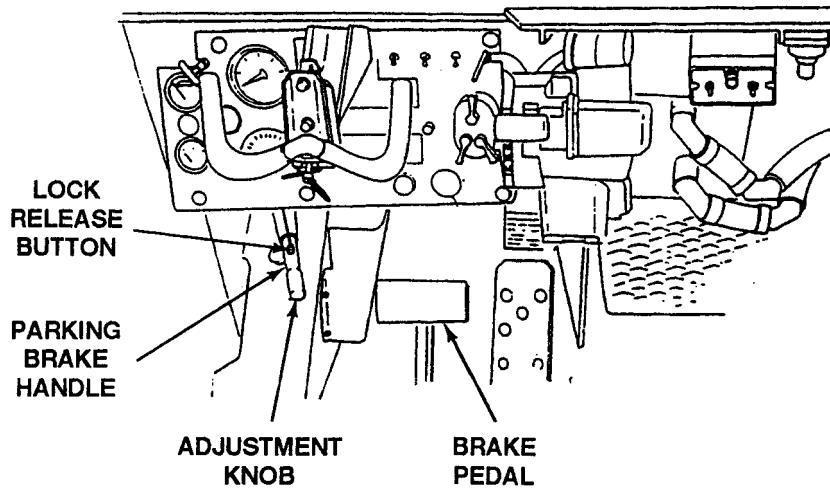

RELEASE

1. Depress and hold brake pedal.
2. Press down on parking brake handle lock.
3. Push down on parking brake handle to release parking brake.

SET/RELEASE PARKING BRAKE (M548A3) — Continued

0012 00

4. Let up on brake pedal.

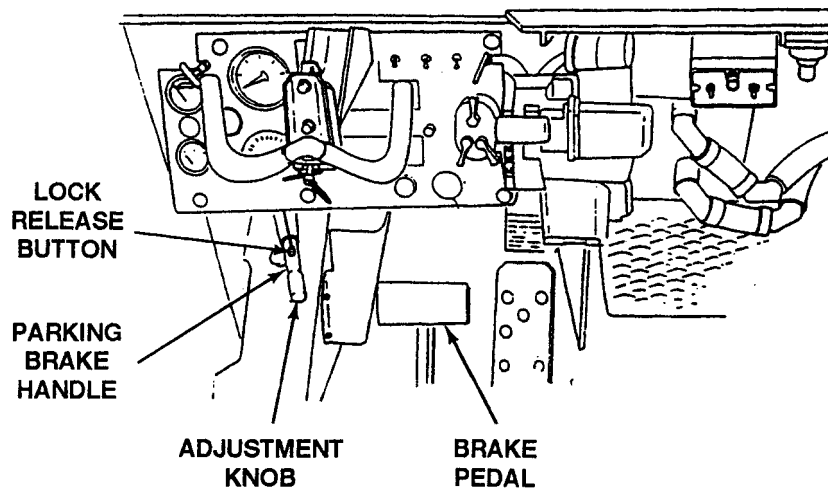
**ADJUST**

1. Depress and hold brake pedal.
2. Turn adjusting knob clockwise as tightly as possible by hand.
3. Apply parking brake handle.
4. If parking brake cannot be applied, turn adjusting knob counterclockwise until parking brake can be applied.

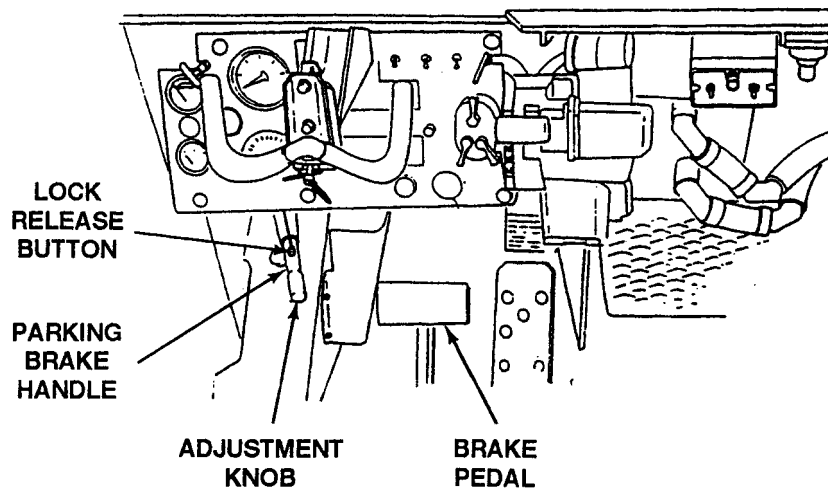

5. Test parking brake:
 - a. Set parking brake.
 - b. Depress brake pedal and start engine (WP 0014 00).
 - c. Place transmission controller in 1 range.
 - d. Slowly let up on brake pedal. Parking brake should hold vehicle. Do not raise RPM over idle.
 - e. If parking brake cannot be adjusted, notify unit maintenance.

END OF TASK

START ENGINE (M548A1)

0013 00

THIS WORK PACKAGE COVERS:

Start Engine (Above 40°F (4°C)) (page 0013 00-2).
Start Engine (Below 40°F (4°C)) (page 0013 00-6).

INITIAL SETUP:

Maintenance Level

Operator

Equipment Condition

Engine stopped (WP 0023 00)

Personnel Required

Driver

START ENGINE (ABOVE 40°F (4°C))

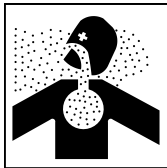
WARNING

Engine exhaust gas can kill or poison you. Make sure power plant access panels are closed tight before you start engine. Do not run engine indoors without very good fresh air flow. Keep power plant access cover closed when you run engine. Check for the smell of exhaust fumes. If you notice any fumes, open doors and turn on vent fans.

WARNING

Personnel could be killed if ammunition or other cargo gets into engine compartment. Do not operate carrier without rear engine access panels and plywood protector installed.

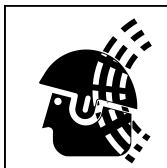
WARNING

Noise from carrier or weapons can damage hearing of personnel in carrier. All personnel in carrier **MUST WEAR DOUBLE HEARING PROTECTION** when carrier is operated. Hearing protection devices must be properly worn to provide effective protection.

If **DOUBLE HEARING PROTECTION** is not worn, the safe level of noise exposure will be exceeded in a short time. Hearing loss occurs gradually. Each noise exposure that exceeds the ear protection guidelines will cause a temporary hearing loss. Over time, loss of hearing will become permanent. Plan each days operation, and be sure all crew and riders have the required ear protectors. Spare foam earplugs must be available.

1. Do the Before (B) Preventive Maintenance Checks and Services (WP 0057 00) each day when you start the engine for the first time.

2. Lock right and left steering levers. Pull back on both levers and press the lock buttons down at the same time.

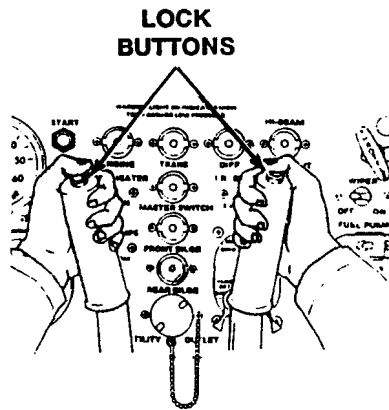

NOTE

The starter will not work unless the transmission range selector is in N range.

3. Put the transmission range selector in N range.

**TRANSMISSION
RANGE SELECTOR**

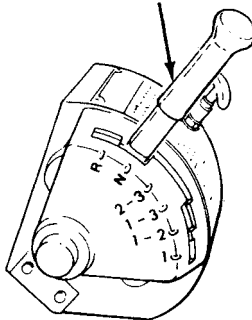

4. Turn the MASTER SWITCH ON.

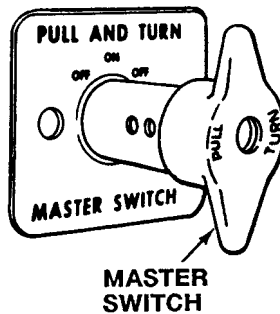

5. Check the instrument panel and make sure the MASTER SWITCH light comes ON.

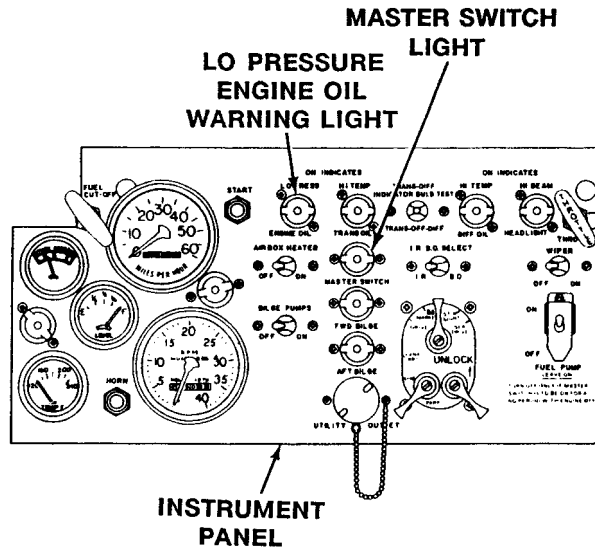

CAUTION

Check for smooth operation of the fuel cut-off cable prior to starting engine.

6. Push in the fuel cut-off.

CAUTION

If the engine doesn't start after 30 seconds of cranking, release the START switch. Wait 30 seconds before you try again. If the engine doesn't start in five tries, troubleshoot it. Make sure the LO PRESS ENGINE OIL warning light goes out within 10 seconds after starting. If any one of the three WARNING lights (top row left) comes on while you're driving the carrier, stop and troubleshoot right away.

7. Press the START switch.

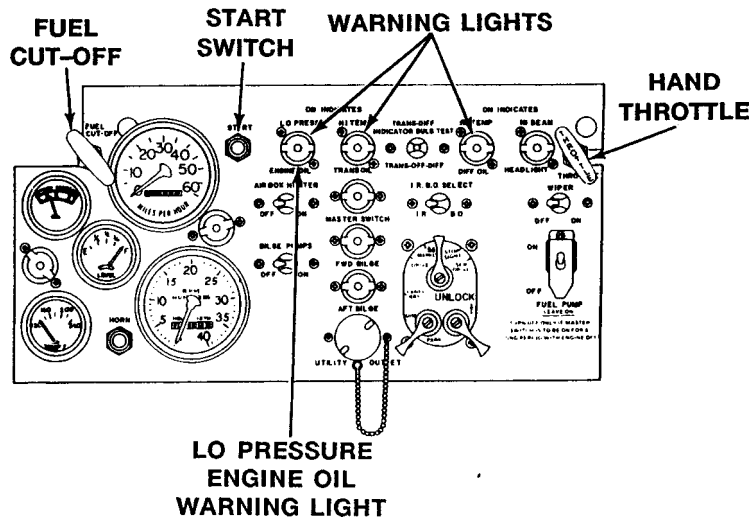

START ENGINE(BELOW 40°F (4°C))

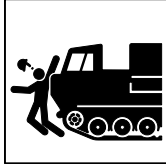
WARNING

Personnel could be killed if ammunition or other cargo gets into engine compartment. Do not operate carrier without rear engine access panels and plywood protector installed.

WARNING

Noise from carrier or weapons can damage hearing of personnel in carrier. All personnel in carrier **MUST WEAR DOUBLE HEARING PROTECTION** when carrier is operated. Hearing protection devices must be properly worn to provide effective protection.

If **DOUBLE HEARING PROTECTION** is not worn, the safe level of noise exposure will be exceeded in a short time. Hearing loss occurs gradually. Each noise exposure that exceeds the ear protection guidelines will cause a temporary hearing loss. Over time, loss of hearing will become permanent. Plan each days operation, and be sure all crew and riders have the required ear protectors. Spare foam earplugs must be available.

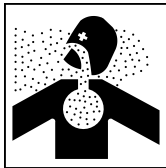
WARNING

Engine exhaust gas can kill or poison you. Make sure power plant access panels are closed tight before you start engine. Do not run engine indoors without very good fresh air flow. Keep power plant access cover closed when you run engine. Check for the smell of exhaust fumes. If you notice any fumes, open doors and turn on vent fans.

NOTE

If temperature is below -25°F (-32°C), you have to follow specific procedures to get the engine ready before you start it. See WP 0039 00 for those special procedures. Then use this procedure to start the engine.

1. Do the Before (B) Preventive Maintenance Checks and Services (WP 0057 00).

2. Lock right and left steering levers. Pull back on both levers and press the lock buttons down at the same time.

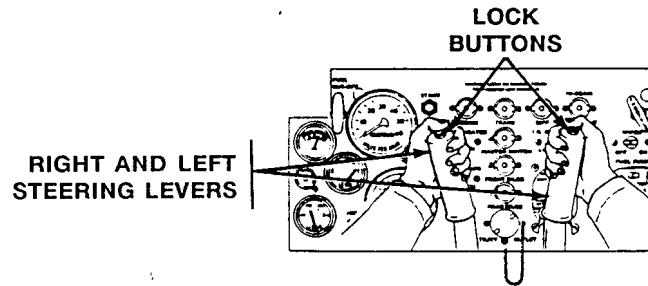

3. Set the transmission range selector in N range.

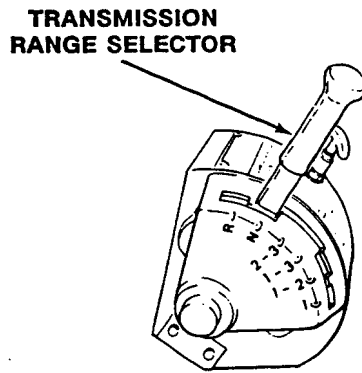

4. Make sure the DRIVING LIGHT switch is OFF and the FUEL PUMP switch is ON.
5. Turn the MASTER SWITCH ON and check the instrument panel. The MASTER SWITCH light should come ON.

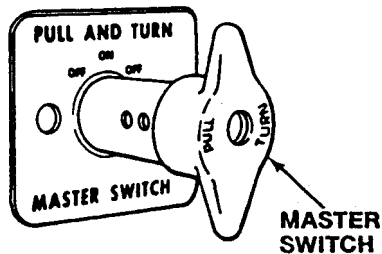
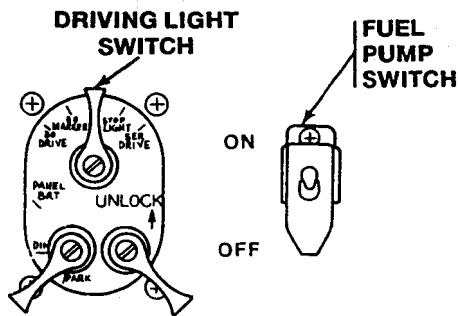

CAUTION

Never try to move the engine disconnect handle when the engine is running.

NOTE

If the temperature is below -25°F (-32°C) and your carrier has an engine coolant heater kit, turn off the coolant heater and close the coolant valves (WP 0040 00).

6. Raise the cab center seat (WP 0011 00) and disengage the engine disconnect.
 - a. Lift the control lock.
 - b. Push the engine disconnect to the rear as far as it will go. This disconnects the engine from the rest of the power plant, so the starter doesn't have to work so hard.

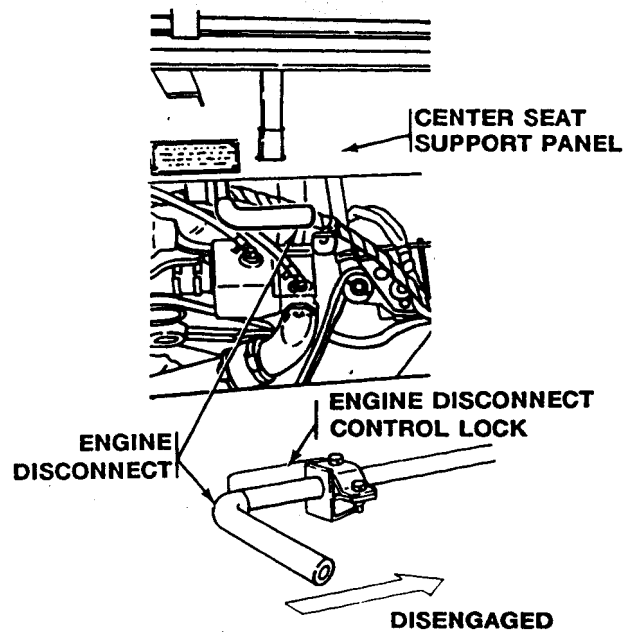
**NOTE**

Use the air box heater to preheat the air going into the engine while you start the engine

7. Lower the cab center seat (WP 0011 00).

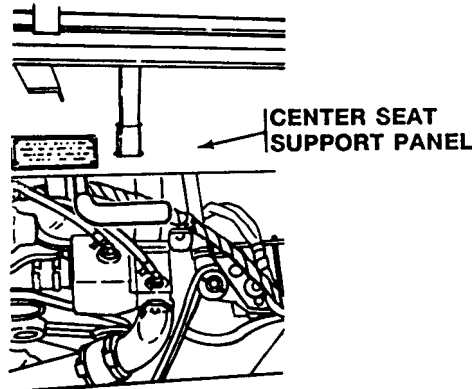

CAUTION

If the engine doesn't start after 15 seconds of cranking, release the START switch. Wait 30 seconds before you try again. If the engine doesn't start in five tries, notify unit maintenance.

8. Push in the fuel cut-off.

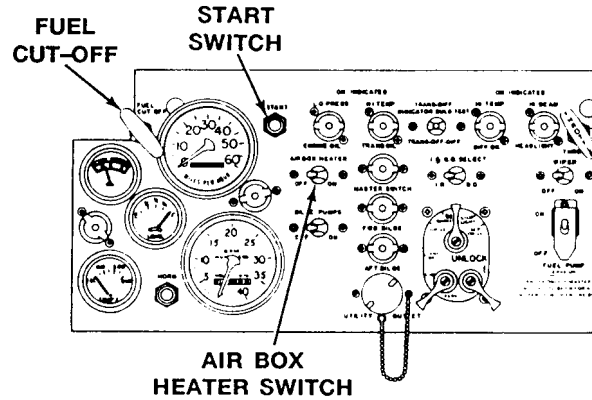

NOTE

Cranking time before pressing accelerator pedal changes with temperature. 45 seconds is for -25°F (-32°C). Crank 5 seconds less for each 5 degrees above -25°F (-32°C), down to a shortest time of 15 seconds. Crank 15 seconds at all temperatures from 10°F to 40°F (-12°C to 4°C).

Within the first 10 seconds engine should give signs of "firing up" or trying to start. When this happens, continue to hold the START and AIR BOX HEATER switches for another 25 seconds. This adds up to the total of 45 seconds for pre-start.

If within the first 20 seconds engine does not give signs of "firing up" or trying to start, stop starting procedures and go to Step 19.

9. Press and hold START switch.
10. Press and hold AIR BOX HEATER switch.
11. Hold both START and AIR BOX HEATER switches for approximately 45 seconds.

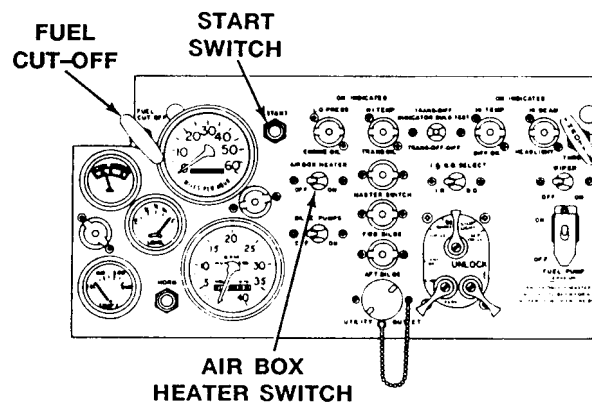

- If the engine doesn't start within 45 seconds of cranking, release the AIR BOX HEATER switch and press the accelerator pedal about halfway down. Keep on holding the START switch.

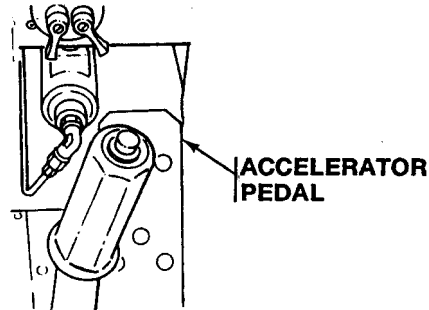

- If the engine doesn't start when you press the accelerator pedal, release the pedal and hold the AIR BOX HEATER switch ON for 10 seconds, then OFF for 3-4 seconds. The engine should start within two of these attempts. If engine starts, go to Step 15.

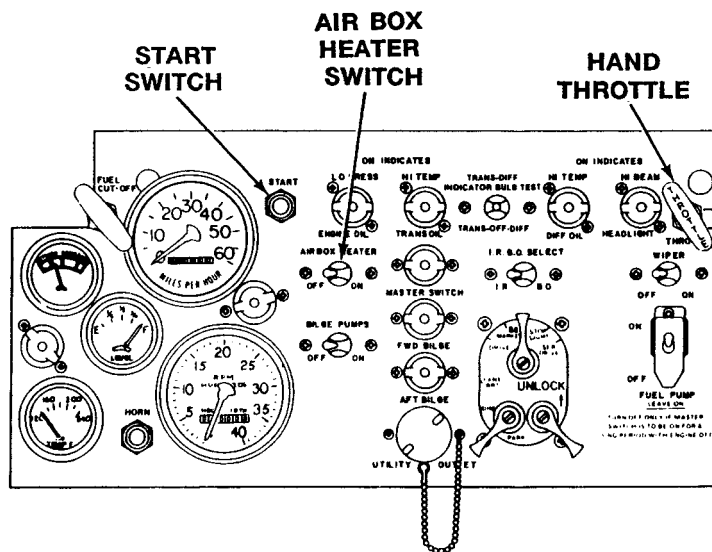

- If the engine doesn't start, release AIR BOX HEATER and START switches. Notify unit maintenance that the air box heater and/or engine should be checked.

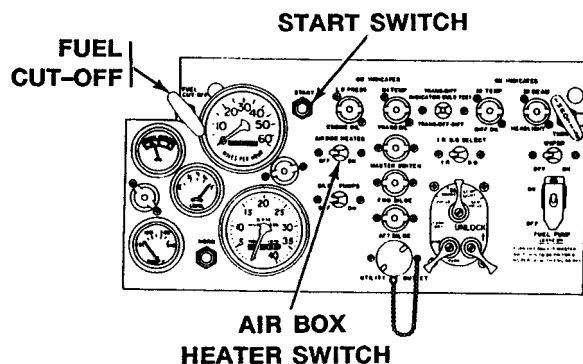

- Set the hand throttle to run the engine at 1,200–1,500 rpm for about 5 minutes. This is to warm up the engine to normal operating temperature (about 160°F (71°C)).

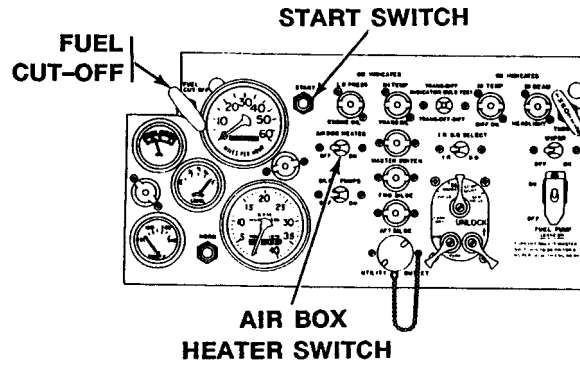

- Check that ENGINE OIL HI TEMP LO PRESS warning light goes OFF within 10 seconds after engine starts.
- Push in the hand throttle. Check that the engine idles at 650–700 rpm.

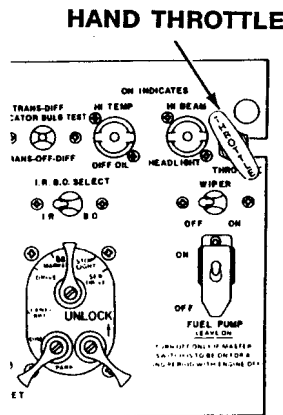

- Pull out the fuel cut-off to stop the engine.

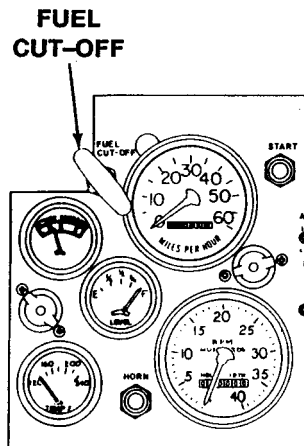

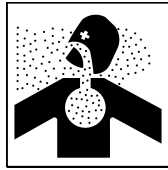
WARNING

Engine exhaust gas can kill or poison you. Make sure power plant access panels are closed tight before you start engine. Do not run engine indoors without very good fresh air flow. Keep power plant access cover closed when you run engine. Check for the smell of exhaust fumes. If you notice any fumes, open doors and turn on vent fans.

CAUTION

Never try to move the engine disconnect handle when the engine is running.

19. Raise the cab center seat (WP 0011 00) and engage the engine disconnect.
 - a. Lift the control lock.
 - b. Pull the engine disconnect to the front as far as it will go. If it's hard to move, press the START switch for a moment to turn the engine a little.
 - c. Lower and secure the cab center seat (WP 0011 00).

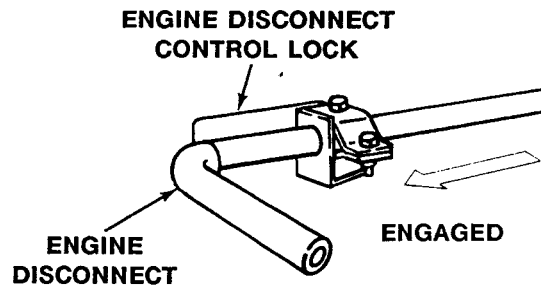

CAUTION

If the engine doesn't start after 30 seconds of cranking, release the START switch and let the starter cool for 30 seconds before you try again. If you can't restart the warm engine in five tries, notify unit maintenance.

20. Push in the fuel cut-off and press the START switch to restart the engine.

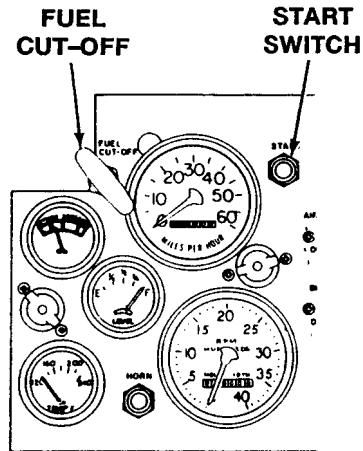
**CAUTION**

Normal idle is 650–700 rpm, and normal coolant temperature is 160°F–230°F (71°C–110°C). If you let the engine run at idle for too long, the engine could cool below 140°F (60°C). Running below 140°F (60°C) for very long can damage the engine. Run the engine at 1,200–1,500 rpm to keep coolant temperature in the normal range.

NOTE

If the instruction plate on the door of your carrier says to warm up the transmission in 1–3 range, you have the wrong plate. Notify unit maintenance.

21. Put the transmission range selector in 2-3 range and set the hand throttle to run the engine at 800–1,000 rpm for about 10 minutes. This is to warm up the transmission.

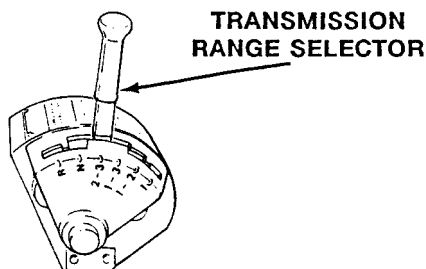

22. Push the hand throttle IN, set the transmission range selector in N range, and do the During (D) Preventive Maintenance Checks and Services (WP 0057 00).

HAND THROTTLE

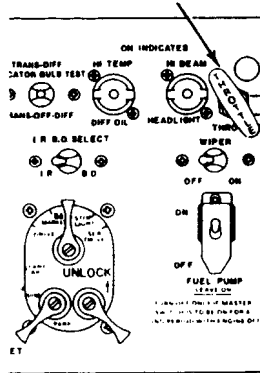

END OF TASK

START ENGINE (M548A3)

0014 00

THIS WORK PACKAGE COVERS:

Start Engine (Above 40°F (4°C)) (page 0014 00-2).
Start Engine (Below 40°F (4°C)) (page 0014 00-8).

INITIAL SETUP:

Maintenance Level

Operator

Equipment Condition

Engine stopped (WP 0024 00)

Personnel Required

Driver

START ENGINE (above 40°F (4°C))

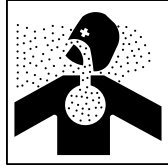
WARNING

Breathing excessive engine exhaust gases can cause death. Make sure cab floor plates and seats are closed tight before you start engine. Keep fresh air flow while running engine.

WARNING

Steering control is lost when steering wheel is locked. Death or injury may result. Unlock steering wheel before moving carrier.

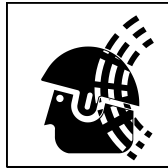
WARNING

Noise from carrier or weapons can damage hearing of personnel in carrier. All personnel in carrier **MUST WEAR DOUBLE HEARING PROTECTION** when carrier is operated. Hearing protection devices must be properly worn to provide effective protection.

If **DOUBLE HEARING PROTECTION** is not worn, the safe level of noise exposure will be exceeded in a short time. Hearing loss occurs gradually. Each noise exposure that exceeds the ear protection guidelines will cause a temporary hearing loss. Over time, loss of hearing will become permanent. Plan each day's operation, and be sure all crew and riders have the required ear protectors. Spare foam earplugs must be available.

WARNING



Do not hold or grab steering wheel when entering or exiting drivers seat. If engine is running and steering wheel locking pin is not installed, applying hand pressure to steering wheel will cause carrier to pivot steer and may result in injury or death.

1. Do Before (B) Preventive Maintenance Checks and Services (WP 0057 00) each day before you start engine for the first time.
2. Turn MASTER SWITCH ON. Check that MASTER SWITCH indicator light comes ON.

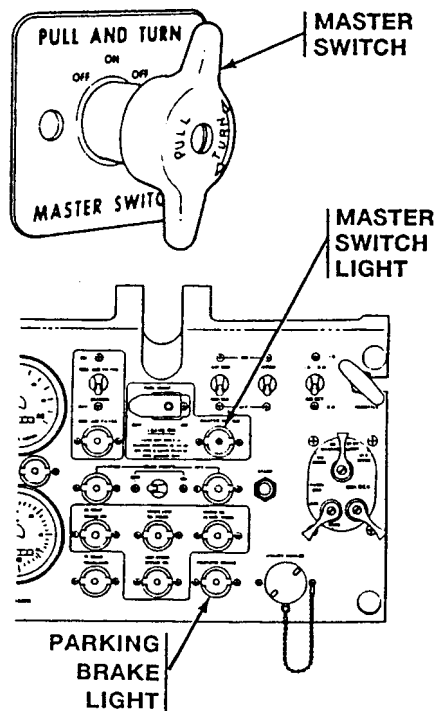

3. Set parking brake by pushing on brake pedal and pulling up on brake handle. Check that parking brake indicator light comes ON.

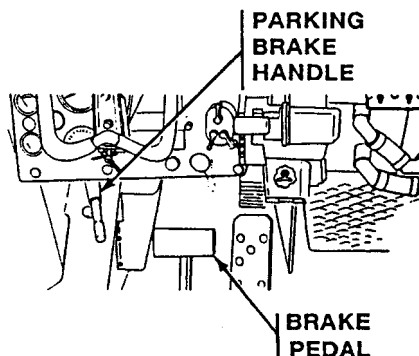

4. Place transmission shift controller in SL (steering wheel lock).
5. Lock steering wheel in center position using steering wheel lock pin.
6. Make sure tow start handle is pushed in all the way and that cover is closed.

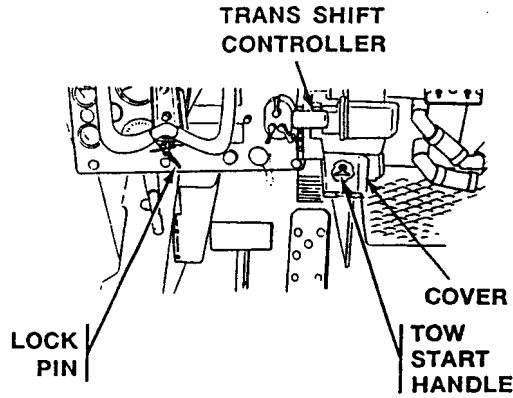

7. Make sure FUEL PUMP switch is ON.
8. Check that LOW PRESSURE ENGINE OIL warning light and TRANSMISSION LOW OIL PRESSURE warning light are ON.
9. Push fuel cut-off control IN all the way.

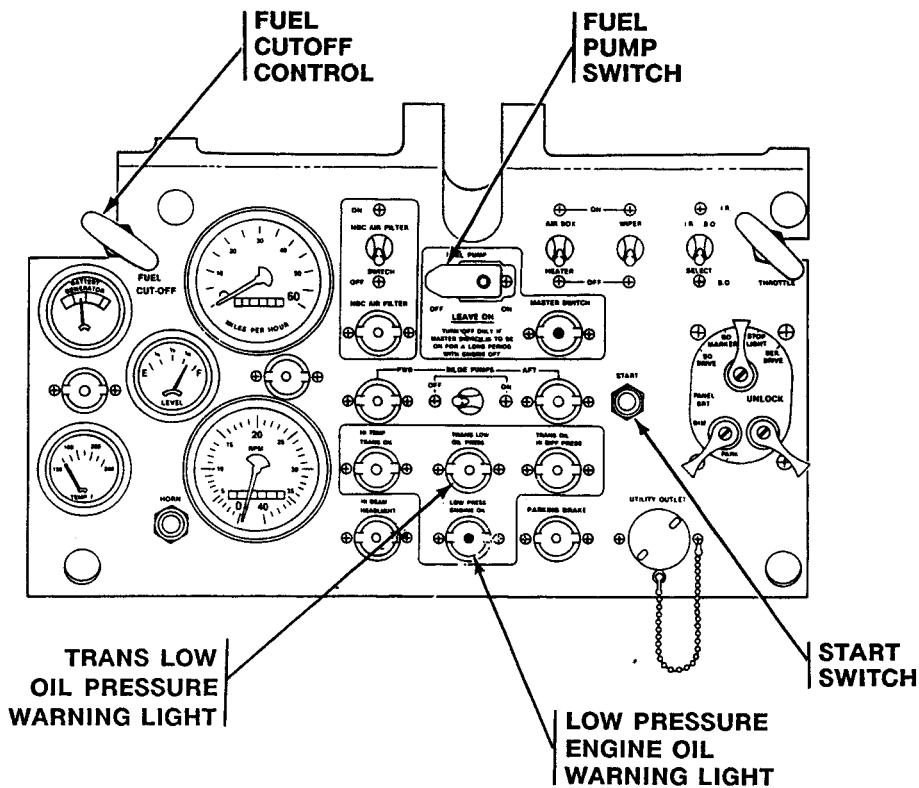

CAUTION

Pressing START switch for more than 15 seconds at temperatures above 40°F (4°C) can damage starter. Do not press START switch for more than 15 seconds at a time. If engine does not start on first try wait at least 30 seconds and try again. If engine fails to start after three attempts notify unit maintenance.

10. Press START switch and hold until engine starts, but no longer than 15 seconds.

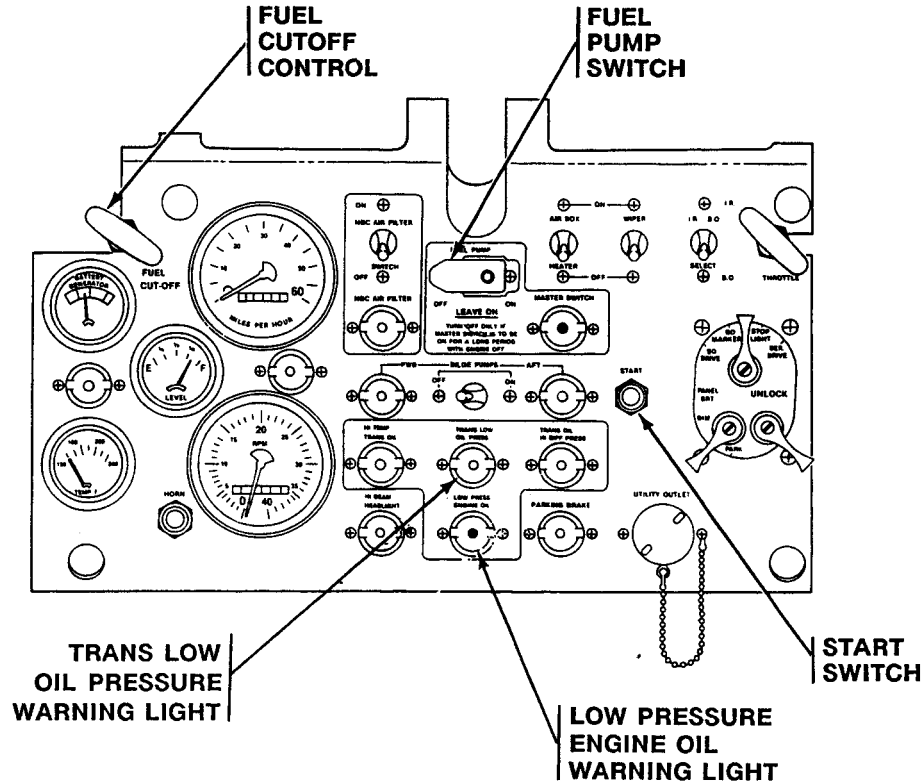

NOTE

It is possible that after engine starts or at engine idle, the TRANSMISSION LOW OIL PRESSURE warning light will be ON.

11. After engine starts, LOW PRESSURE ENGINE OIL warning light and TRANSMISSION LOW OIL PRESSURE warning light should go OFF.

12. Set hand throttle to run engine at 800–1,000 rpm for 3–5 minutes.

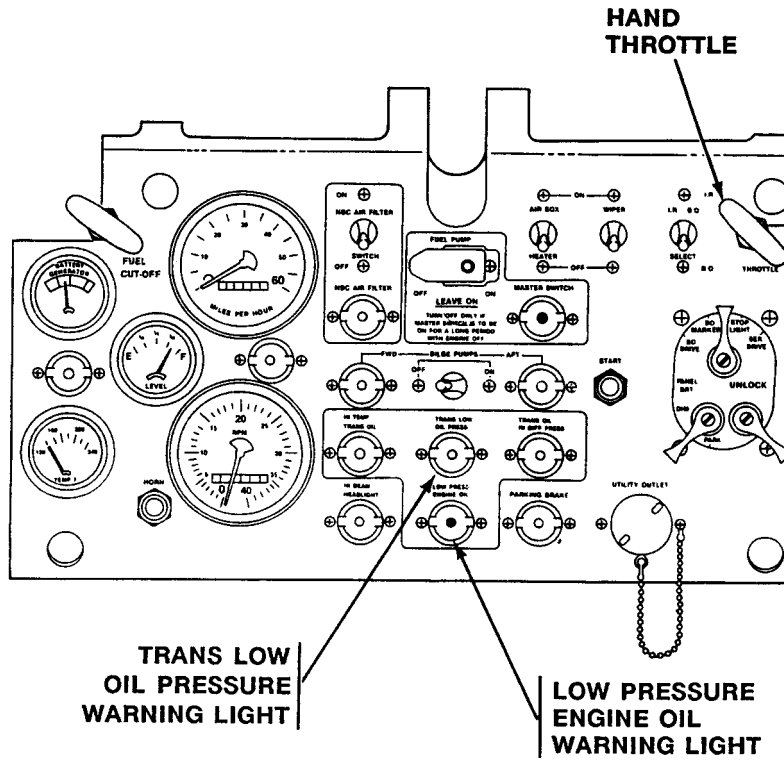

CAUTION

Avoid prolonged engine idling. This causes coolant temperature to drop below operating temperature and is detrimental to the life of the engine. Engine should be run at 1,000–1,200 rpm under no load conditions for prolonged idle.

13. Set hand throttle to run engine at idle speed (600–650 rpm). Check instrument panel for warning lights.

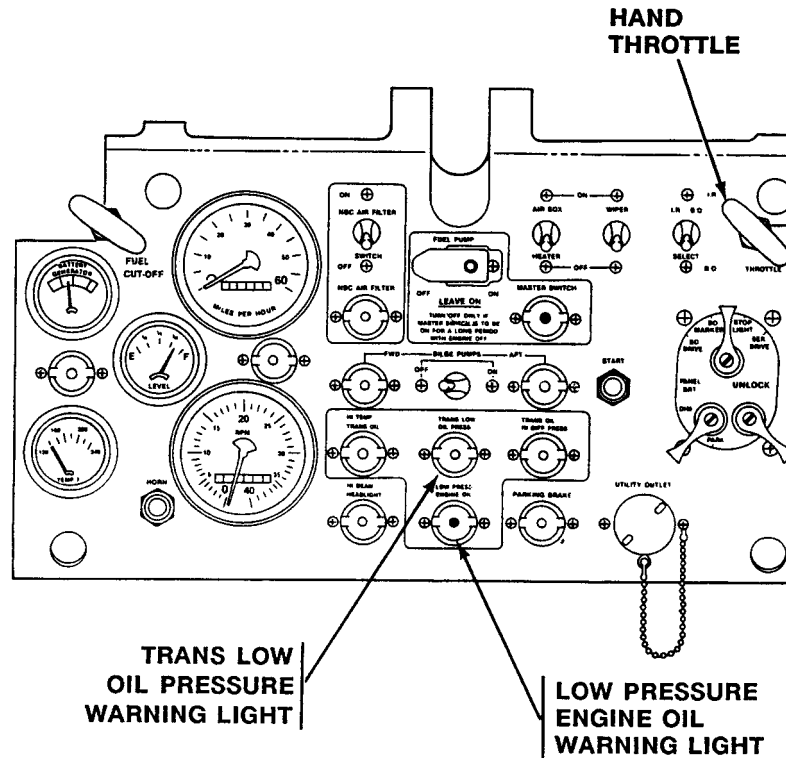

14. When engine is warmed up, do During (D) Preventive Maintenance Checks and Services (WP 0057 00).

START ENGINE (below 40°F (4°C))

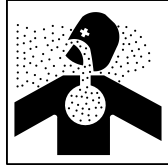
WARNING

Breathing excessive engine ex-haust gases can cause death. Make sure cab floor plates and seats are closed tight before you start engine. Keep fresh air flow while running engine. See front cover warning on fumes.

WARNING

Do not hold or grab steering wheel when entering or exiting drivers seat. If engine is running and steering wheel locking pin is not installed, applying hand pressure to steering wheel will cause carrier to pivot steer and may result in injury or death.

WARNING

Steering control is lost when steering wheel is locked. Death or injury may result. Unlock steering wheel before moving carrier.

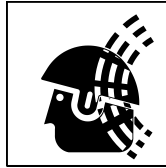
WARNING

Excessive carrier/weapon noise can damage hearing. Wear hearing protection when carrier/weapon is operated. Noise from carrier or weapons can damage hearing of personnel in carrier. All personnel in carrier **MUST WEAR DOUBLE HEARING PROTECTION** when gun or carrier is operated. Hearing protection devices must be properly worn to provide effective protection.

If **DOUBLE HEARING PROTECTION** is not worn, the safe level of noise exposure will be exceeded in a short time. Hearing loss occurs gradually. Each noise exposure that exceeds the ear protection guidelines will cause a temporary hearing loss. Over time, loss of hearing will become permanent. Plan each day's operation, and be sure all crew and riders have the required ear protectors. Spare foam earplugs must be available.

NOTE

If the temperature is below -25°F (-32°C), see WP 0039 00 for starting engine.

If the temperature is below -25°F (-32°C) and engine coolant heater was used to warm coolant, prior to engine start procedure, shut down engine coolant heater.

1. Do Before (B) Preventive Maintenance Checks and Services (WP 0057 00).
2. Turn MASTER SWITCH ON. Check that MASTER SWITCH indicator light comes ON.

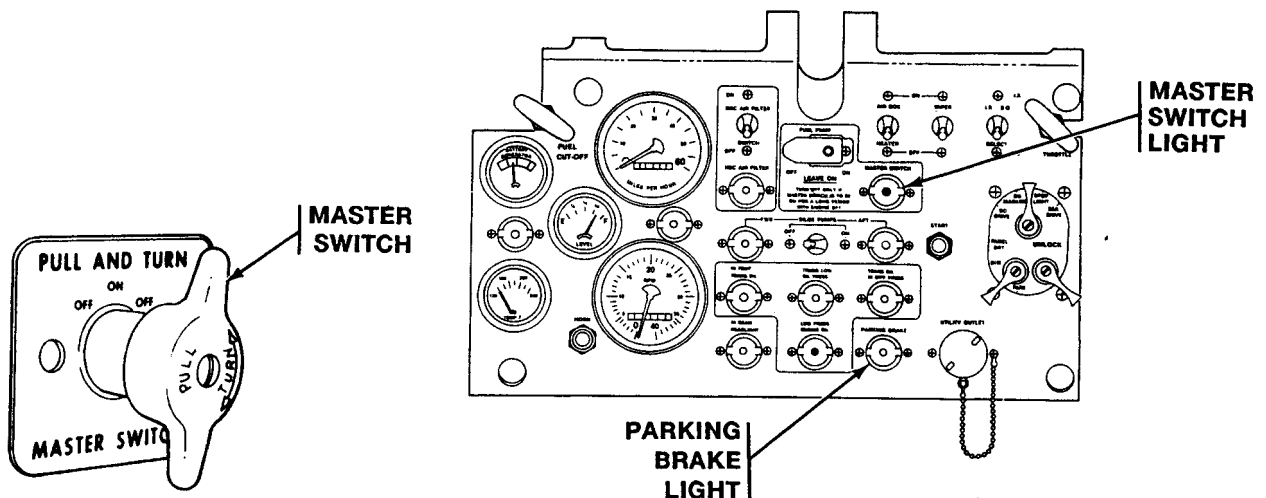

3. Set parking brake by pushing on brake pedal and then pull up on parking brake handle. Check that parking brake indicator light comes ON.
4. Place transmission shift controller in SL (steering wheel lock).
5. Lock steering wheel in center position using steering wheel lock pin.

6. Make sure tow start handle is pushed IN all the way and that cover is closed.

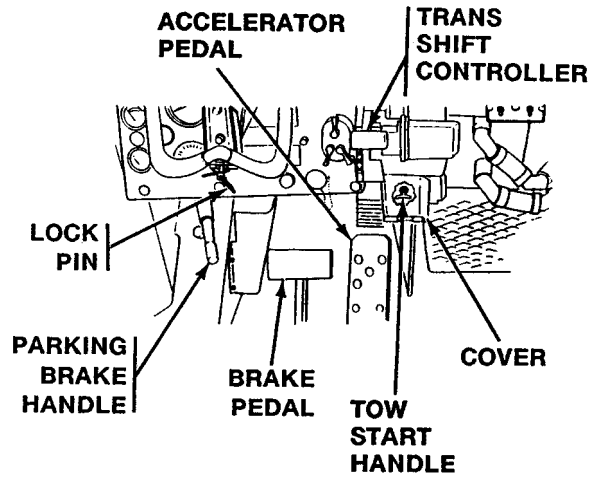

7. Make sure driving lights switch is OFF.
8. Make sure fuel pump switch is ON.
9. Check that LOW PRESSURE ENGINE OIL warning light, TRANSMISSION LOW OIL PRESSURE warning light, MASTER SWITCH ON indicator light, and parking brake indicator light are ON.
10. Push fuel cut-off control IN all the way.

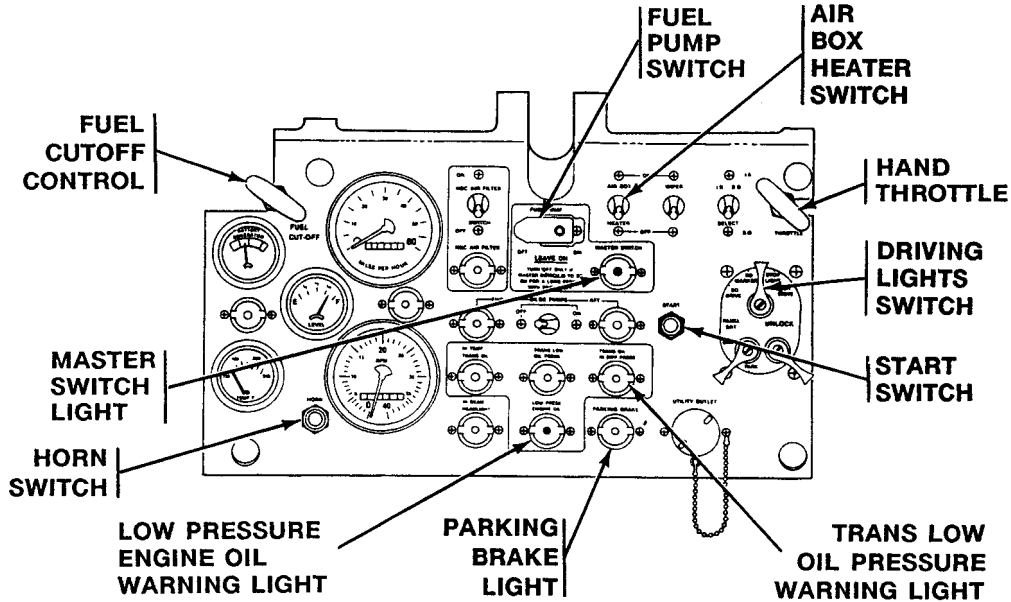

CAUTION

Air pump may over speed and be damaged when operated while starter is not operating. Operate air pump only after starter is in operation.

NOTE

If tactical situation permits, horn should be sounded to warn personnel that engine is about to be started.

11. Press horn switch.
12. Leave throttle lever at idle position.

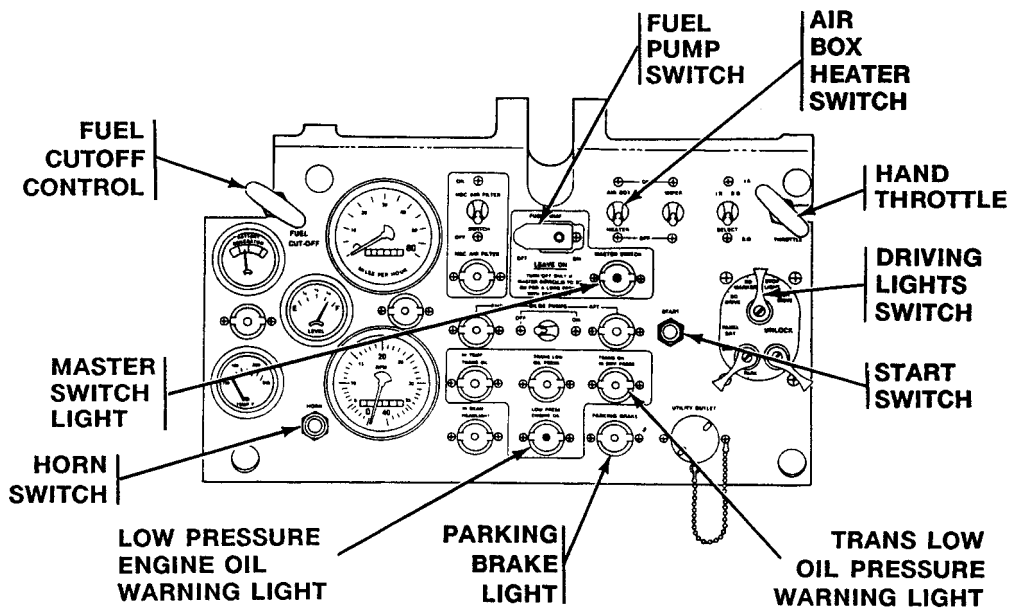
**NOTE**

Within the first 20 seconds engine should give signs of “firing up” or trying to start. When this happens, continue to hold the START and air box heater switches for 25 more seconds. This adds up to the total 45 seconds for prestart. If, within the first 20 seconds, the engine does not give signs of “firing up” or trying to start, go to Step 20.

13. Press and hold START switch.
14. Press and hold air box heater switch.

15. With foot off throttle pedal, press and hold both START and air box heater switches for approximately 45 seconds.

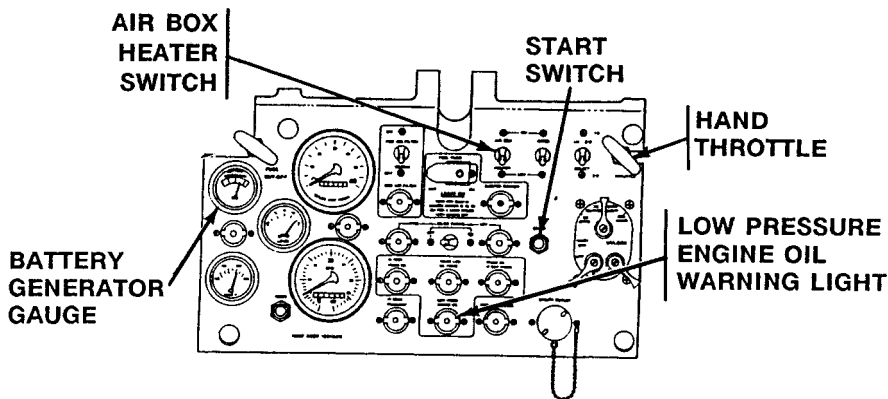

NOTE

Release air box heater switch or engine will not run.

16. After the forty-five seconds of prestart, release air box heater switch and depress foot throttle approximately halfway.
17. If engine starts, release START switch. Immediately adjust engine speed to 1,800–2,000 rpm and set hand throttle. Go to Step 21.
18. If engine does not start, return foot throttle to idle position. Press and hold both START and air box heater switches.
19. Hold air box heater switch for 10 seconds, then release for 3–4 seconds. Engine should start within two of these attempts.
20. If engine does not start, release air box heater and START switches. Notify unit maintenance that air box heater and/or engine should be checked.
21. Check that low pressure engine oil warning light goes OFF within 10 seconds after engine starts.
22. Check that BATT GEN indicator points to green zone.
23. Run engine at 1,800–2,000 rpm for about 5 minutes or until engine coolant gauge indicates 185°F (85°C).
24. Set hand throttle to run engine at idle speed (600–650 rpm).
25. Do During (D) Preventive Maintenance Checks and Services (WP 0057 00).

END OF TASK

START ENGINE WITH EXTERNAL POWER

0015 00

THIS WORK PACKAGE COVERS:

Start Engine with External Power (page 0015 00-1).

INITIAL SETUP:

Maintenance Level

Operator

Personnel Required

Driver (2)

Tools and Special Tools

Slave Cable
Source Carrier

Equipment Condition

Carrier unable to start under own power

START ENGINE WITH EXTERNAL POWER

CAUTION

Do not start carrier without batteries installed. Starting engine with outside power and no batteries will damage voltage regulator.

1. Position source carrier next to dead carrier so that slave cable can connect auxiliary power receptacles on both carriers. Stop engine on source carrier.
2. Make sure MASTER SWITCH is OFF on both carriers.

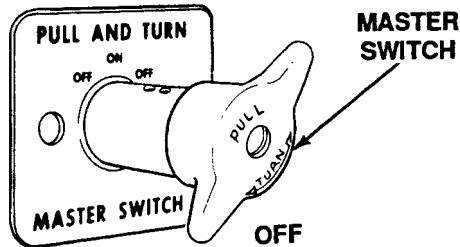

NOTE

Step 3 and Step 4 are for M548A1.

3. Unscrew the cap from your auxiliary power receptacle.

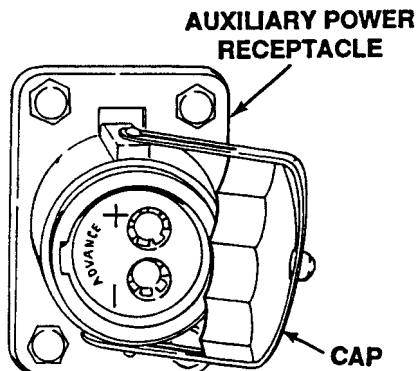

WARNING

Electrical slave cable can be improperly connected causing electrical shock or fire. Death or injury could result. Equipment can be damaged. Match the connector guide lug and cable prongs with receptacle hole.

CAUTION

Make sure cable prongs match the receptacle holes, + to + and - to -.

4. Connect the slave cable to the receptacle on dead carrier, then to the auxiliary power receptacle on the source carrier.

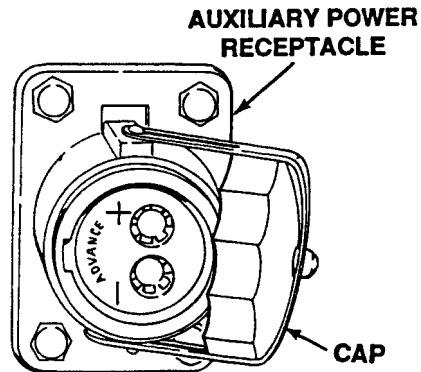

NOTE

Step 5 and Step 6 are for M548A3.

5. Remove cap from auxiliary power receptacle on both carriers.

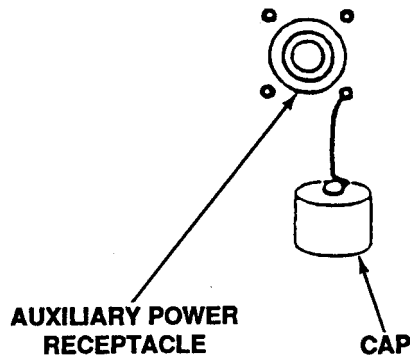

6. Connect slave cable to receptacle in dead carrier and to receptacle in source carrier.
7. Start engine of source carrier. Make sure engine is running fast enough to show charging on carrier's battery-generator gauge.

NOTE

**In cold weather, airbox heater of dead carrier can be turned on to heat dead carrier's engine.
See WP 0013 00 or WP 0014 00.**

8. Start engine of dead carrier (WP 0013 00) for M548A1 or (WP 0014 00) for M548A3. When engine is running smoothly, disconnect slave cable from receptacle on both carriers.
9. Install cap on auxiliary power receptacle on both carriers.

END OF TASK

START/DRIVE CARRIER WITH NO ELECTRICAL POWER OR WITH FAULTY TRANSMISSION SHIFT CONTROLLER (M548A3)

0016 00

THIS WORK PACKAGE COVERS:

Electrical or Transmission Shift Controller Failure while Driving (page 0016 00-1).
 Start/Drive Carrier with Electrical or Transmission Shift Controller Failure (page 0016 00-2).

INITIAL SETUP:

Maintenance Level

Operator

Personnel Required

Driver

ELECTRICAL OR TRANSMISSION SHIFT CONTROLLER FAILURE WHILE DRIVING

NOTE

If transmission is in any forward range it will automatically shift to 1-4 range. When engine is shut down the transmission will automatically shift to pivot range (PV).

If transmission is in reverse (R) at time of malfunction, it will stay in reverse until engine is shut down.

A shifting problem may be caused by a carrier electrical failure, damage to transmission shift controller wiring harness, or damage to transmission shift controller.

1. Continue driving carrier only if necessary.
2. Complete DA Form 2404. Notify unit maintenance.

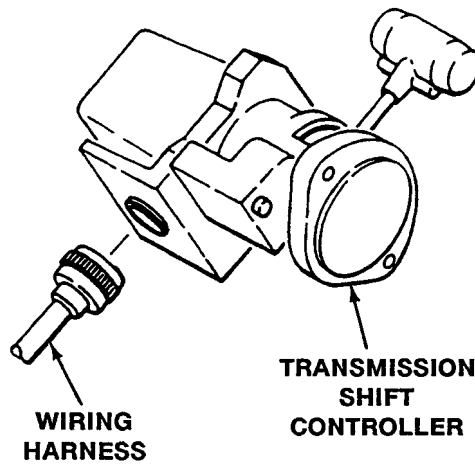

**START/DRIVE CARRIER WITH NO ELECTRICAL POWER OR WITH FAULTY
TRANSMISSION SHIFT CONTROLLER (M548A3) — Continued**

0016 00

START/DRIVE CARRIER WITH ELECTRICAL OR TRANSMISSION SHIFT CONTROLLER FAILURE**NOTE**

When engine is shut down the transmission will automatically shift to pivot range (PV). When the wiring harness is disconnected from transmission shift controller, carrier must be tow started.

1. Disconnect wiring harness from back of transmission shift controller.

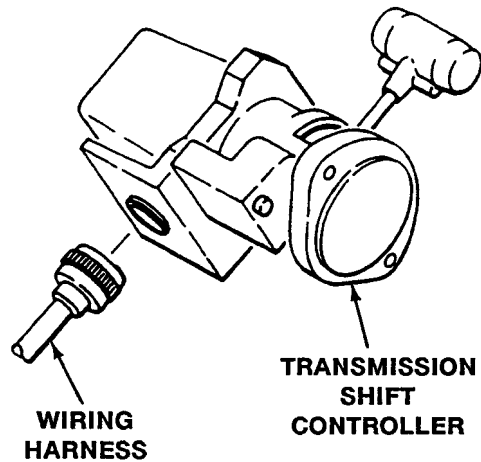

2. Tow start carrier (WP 0052 00).

NOTE

Upon engine start-up transmission will automatically shift to 1-4 range.

3. Complete DA Form 2404. Notify unit maintenance.

END OF TASK

LOAD CARGO

0017 00

THIS WORK PACKAGE COVERS:

- General Precautions (page 0017 00-1).
 - Getting Carrier Ready (page 0017 00-1).
 - Loading Ammunition Supply (page 0017 00-2).
-

INITIAL SETUP:

Maintenance Level

Operator

Equipment Condition

Engine stopped (WP 0023 00), (WP 0024 00)
Carrier blocked (WP 0038 00)

Personnel Required

Driver (2)

GENERAL PRECAUTIONS

CAUTION

Never load more than 6 tons (4,800 kg) in the carrier.

1. Load the heaviest items first, so they'll be on the bottom. The carrier will handle better and safer when the weight of the load is low.
2. Keep the load balanced side-to-side.
3. Keep the load weight centered about 56 inches (142 cm) behind the power plant compartment bulkhead. This is so the balance point of the loaded carrier will stay close to the middle roadwheels. You can line up the load with the third cover bow from the front. It's about 54 inches (136 cm) back of the bulkhead and that's close enough.
4. If your carrier has the material handling kit, always center the hoist beam and secure it in the full-forward position before you drive off. Secure the chains and hook to the beam with a strap, to keep them from banging into the carrier.
5. If you're loading 155 mm, 175 mm, or 8 inch ammunition, follow the loading charts under Loading Ammunition Supply Procedure Step 1 on next page.
6. If you're carrying men in the cargo compartment, remember that they're part of the load too. Plan your loading to allow for them.

GETTING CARRIER READY

NOTE

Cargo compartment floor plates are used in two positions. In high position, floor plates are placed even with sponsons for a wide floor. In low position, floor plates are placed down between sponsons to allow room for high loads or provide leg room for crew members. If the rear lifting eyes are in the way you can take them off and stow them under the floor plates.

1. Getting carrier ready.

LOADING AMMUNITION SUPPLY

WARNING



If ammunition or other cargo gets into the engine compartment personnel may be killed. Do not operate carrier without rear engine access covers and plywood protector installed.

- To load 155 mm, 175 mm or 8 inch ammunition, use the following loading charts. For loading other cargo see General Precautions Procedure Steps 1 - 6.

48 PROPELLANT CANNISTERS
(4 GROUPS OF 12)

6 FUZE BOXES

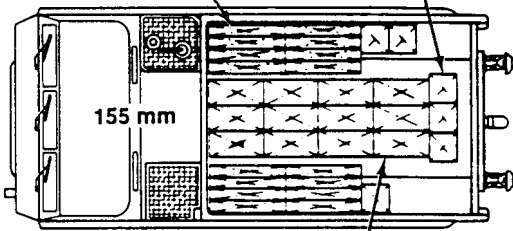

155 mm

96 PROJECTILES
(8 PER PALLET)

36 PROPELLANT CANNISTERS
(9 COLUMNS OF 4)

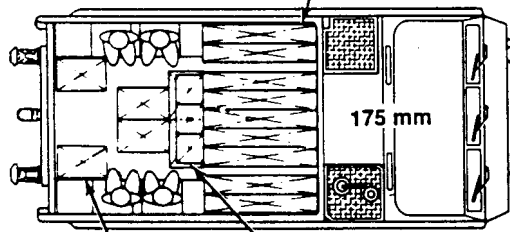

175 mm

3 FUZE BOXES

36 PROJECTILES
(6 PER PALLET)

36 PROPELLANT CANNISTERS
3 FUZE BOXES

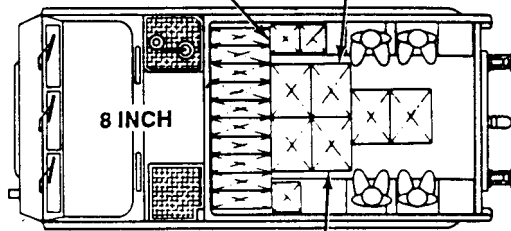

8 INCH

36 PROJECTILES
(6 PER PALLET)

END OF TASK

CHECK INSTRUMENT PANEL (M548A1)

0018 00

THIS WORK PACKAGE COVERS:

Check Instrument Panel (page 0018 00-1).

INITIAL SETUP:

Maintenance Level

Operator

Equipment Condition

Engine stopped (WP 0023 00)

Personnel Required

Driver

CHECK INSTRUMENT PANEL

1. Check the instrument panel before you move the carrier, and keep an eye on panel while you're driving. If you get a reading or indication that isn't normal, stop and fix the problem before you move on. A normal instrument panel should look something like this.
2. The LOW PRESS ENGINE OIL light will come ON if engine oil pressure drops too low. If this happens, troubleshoot the engine (WP 0055 00).

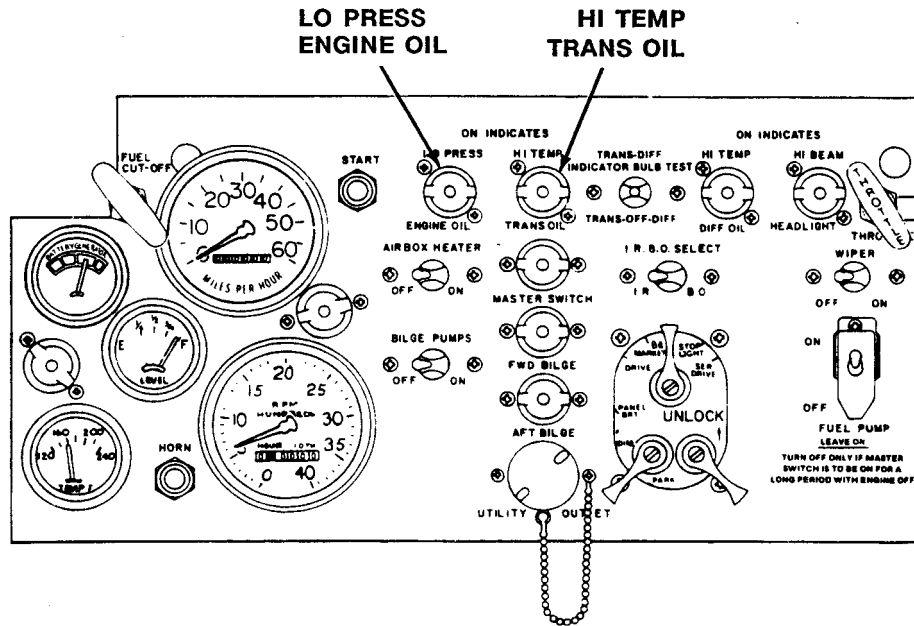

3. The HI TEMP TRANS OIL light will come ON if the temperature of the transmission oil goes above 300°F to 310°F (149°C to 154°C). If the light comes on, troubleshoot the transmission (WP 0055 00).

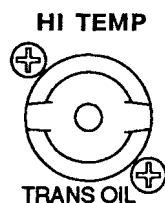

- The HI TEMP DIFF OIL light will come ON if the temperature of the differential oil goes above 300°F to 310°F (149°C to 154°C). Then you have to troubleshoot the differential (WP 0055 00).

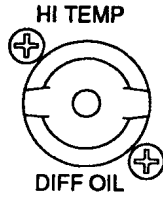

- The coolant temperature gauge may show a normal operating temperature between 160°F and 230°F (71°C and 110°C). Any temperature in this range is OK. If the temperature goes higher than 230°F (110°C), troubleshoot the engine (WP 0055 00). Normally the temperature won't go below 160°F (71°C) once the engine warms up unless you have to idle in arctic temperatures (below -25°F (-32°C)). If the coolant temperature drops to 140°F (60°C), run the engine at 1200–1500 rpm until it warms up. If the temperature gauge doesn't work, notify unit maintenance.

NORMAL RANGE

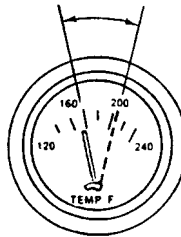

- The battery-generator gauge actual conditions are: LOW (left red zone) = Dead battery or short circuit; DISCHARGE (yellow zone) = Upper (right) half OK with engine off, lower (left) half indicates low battery; CHARGE (green zone) = OK with engine on; HIGH (right red zone) = Overcharge. If the needle stays in either red (low or high) zone, shut down engine and notify unit maintenance. The pointer can vary to the right or left depending on battery condition or electrical equipment in use.

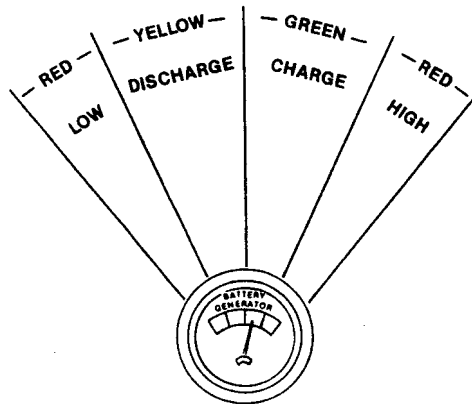

END OF TASK

CHECK INSTRUMENT PANEL (M548A3)

0019 00

THIS WORK PACKAGE COVERS:

Check Instrument Panel (page 0019 00-1).

INITIAL SETUP:

Maintenance Level

Operator

Equipment Condition

Engine stopped (WP 0024 00)

Personnel Required

Driver

CHECK INSTRUMENT PANEL (M548A3)

1. Check the instrument panel. It should look like the picture when the engine is warm and at idle speed with the parking brake set. MASTER SWITCH indicator light and PARKING BRAKE indicator light should be ON. Tachometer should read 600–650 rpm. Engine coolant temperature gauge should begin to rise. Fuel gauge reflects amount of fuel in fuel tank. All warning lights should be OFF. See below for more information on warning lights, engine coolant temperature gauge, and battery-generator gauge.

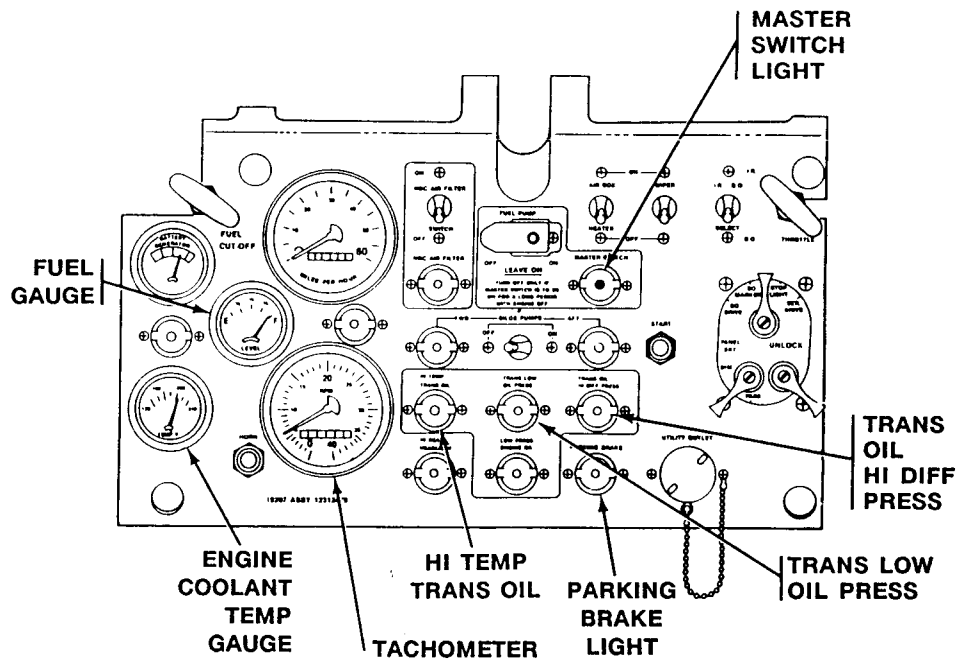

2. HI TEMP TRANS OIL warning light comes ON when transmission oil temperature is above safe operating range. If warning light comes ON, troubleshoot transmission (WP 0055 00).

- TRANS LOW OIL PRESS warning light comes ON when transmission oil pressure may be below safe operating range. To check, place transmission shift controller in SL (Steering Wheel Lock). Increase engine speed to at least 1600 rpm and then reduce it to 1400 rpm. If warning light remains ON, troubleshoot transmission (WP 0055 00).

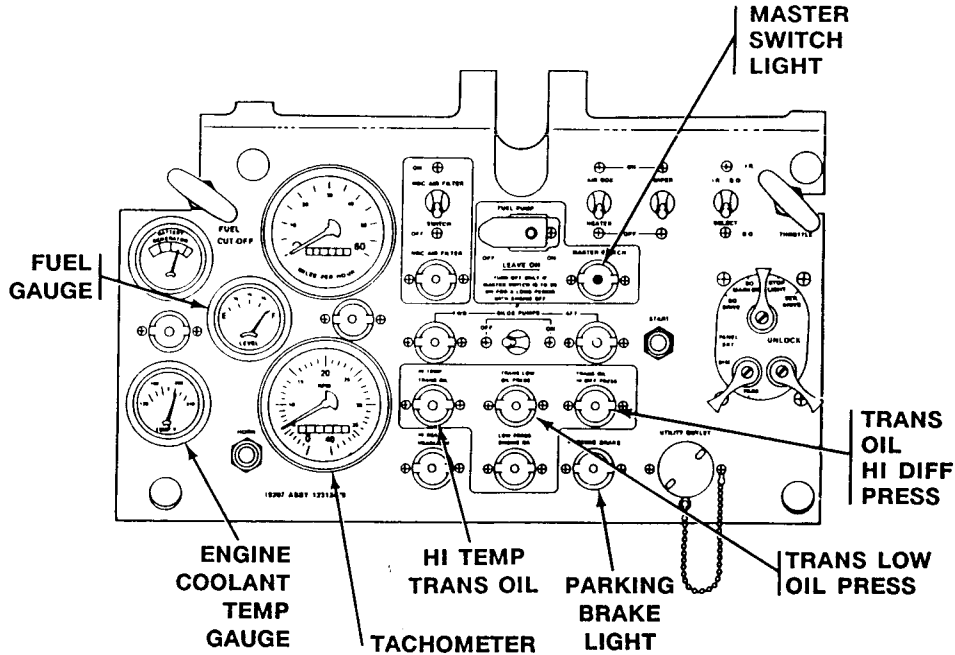

NOTE

TRANS LOW OIL PRESS warning light may come ON when brakes are released. The light should go OFF when engine speed reaches about 1400 rpm.

- TRANS OIL HI DIFF PRESS warning light comes ON when transmission oil filter requires maintenance action. If warning light comes ON, notify unit maintenance.

5. **LOW PRESS ENGINE OIL** warning light comes ON when engine oil pressure is below safe operating range. If warning light comes ON, troubleshoot engine (WP 0057 00).

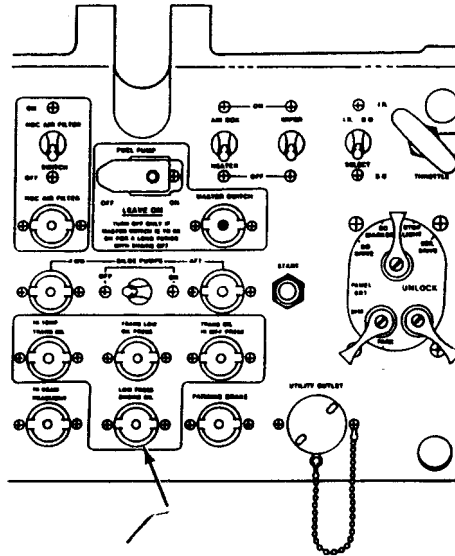

**LOW PRESS
ENGINE OIL**

6. Engine coolant temperature gauge may show a normal operating temperature between 160F and 230F (71°C and 110°C). Any temperature in this range is OK. If temperature goes higher than 230F (110°C), troubleshoot engine (WP 0055 00). Normally the temperature will not go below 185F (85°C) once the engine warms up unless operating in arctic temperatures (below -25F (-32°C)). If engine coolant temperature drops below 160F (71°C), run engine at 1200–1500 rpm until it warms up. If temperature gauge does not work, notify unit maintenance.

NORMAL RANGE

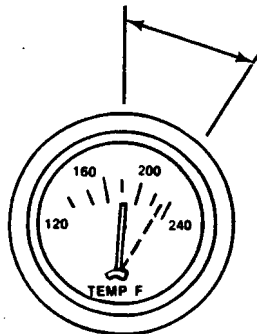

7. The battery-generator gauge actual conditions are: **LOW** (left red zone) = Dead battery or short circuit; **DISCHARGE** (yellow zone) = Upper (right) half OK with engine off, lower (left) half indicates low battery; **CHARGE** (green zone) = OK with engine on; **HIGH** (right red zone) = Overcharge. If the needle stays in either red (low or high) zone, shut down engine and notify unit maintenance. The pointer can vary to the right or left depending on battery condition or electrical equipment in use.

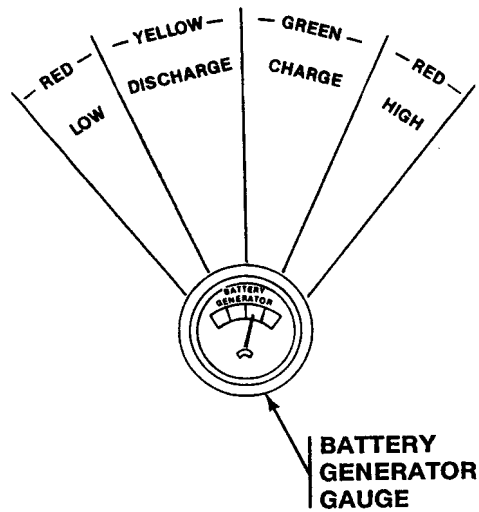

END OF TASK

DRIVE CARRIER (M548A1)

0020 00

THIS WORK PACKAGE COVERS:

- Driving Precautions (page 0020 00-1).
 - Drive Carrier (page 0020 00-3).
 - Select Driving Range (page 0020 00-11).
-

INITIAL SETUP:

Maintenance Level

Operator

References

TB Med 507

Personnel Required

Driver

Equipment Condition

Engine started (WP 0013 00)

DRIVING PRECAUTIONS

WARNING



When a track carrier gets out of control and overturns, it is safer to stay in the carrier than to try to get out while the carrier is still moving. You may receive slight injuries from being thrown against metal parts; but if you try to leave the carrier, it may roll over and crush you. Once the carrier stops moving, get out as fast as possible because spilled fuel and oil may catch on fire. The first thing the driver should do in such an emergency is shut off the engine and turn off the MASTER SWITCH to minimize the fire hazard.

1. Use 1-2 range until you get used to driving carrier.

**TRANSMISSION
RANGE SELECTOR**

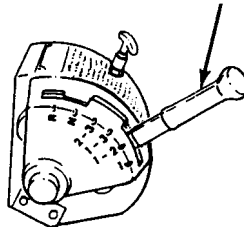

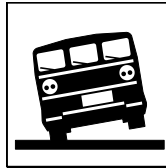
WARNING

Avoid oversteering at high speeds to prevent skidding or carrier upset. Personnel may be killed or injured if carrier overturns. Use caution when turning on hills or side slopes, or at high speeds.

2. Take care not to oversteer or go too fast, especially on hard pavement. You could lose control of carrier.

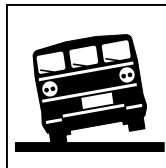
WARNING

Decelerate when carrier approaches brink of a trench or ditch and at a crest or on downgrade of a hill to avoid losing control of carrier and injury. Accelerate when carrier bottoms in a trench or ditch or when climbing a hill.

3. Slow down when you get to the top of a hill or the edge of a trench or ditch.
4. Use a low range (1 or 1-2) when driving down steep hills, and keep your speed down. Going down a trench or ditch, take care not to let the front of the carrier dig in at the bottom.
5. On loose sand, dirt, or rock, especially on side slopes, steer in several short turns to let track clear itself of rocks, dirt, branches, and other junk. In really heavy sand, mud, snow, or heavy growth, have unit maintenance take off track shrouds.
6. Don't use engine and transmission to hold carrier on a slope. Use brakes or block tracks with large rocks or logs.
7. Except in an emergency, don't use hand throttle for driving.

DRIVE CARRIER

WARNING

Carrier movement can throw you from your seat and injure you. Use of seat belts is mandatory. See warning in front of manual.

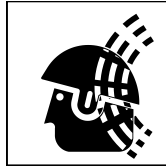
WARNING

Carrier noise can cause permanent hearing damage. Double hearing protection must be worn. See warning in front of manual.

WARNING

Vehicle operation during hot weather may result in heat stress to crew members. Crew members should limit their exposure to high temperature and humidity based on TB Med 507, using PHEL chart (WP 0082 00) curve as a guide.

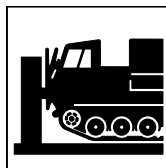
WARNING

Sticking or failed linkage can cause carrier crash. Personnel can be killed or injured. If accelerator pedal does not operate smoothly, or engine does not return to idle when accelerator pedal is released, do not drive carrier.

WARNING

Brake pedal is very sensitive. Applying brake hard can cause carrier to stop suddenly. personnel could be injured. Apply brake pressure lightly and with caution.

1. Make sure cab and cargo doors are closed and latched. Have all personnel fasten their seat belts.
2. START ENGINE (WP 0013 00).
3. Set the transmission range selector to the driving range you want. See WP 0020 00 for selecting driving range.

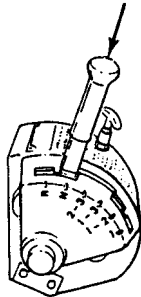
**TRANSMISSION
RANGE SELECTOR**

4. If tactical situation permits, press horn switch to sound horn and warn personnel that carrier is about to move.

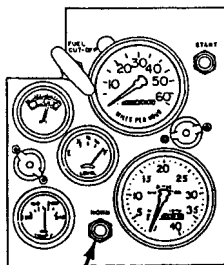
**HORN SWITCH**

5. Pull back on the right and left steering levers so the lock buttons pop up, then let levers go forward gently.

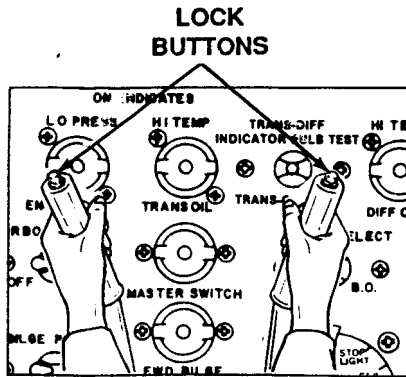

6. Step on the accelerator pedal. Go easy. Take off nice and smooth. Push on the pedal to control the speed. The transmission will shift automatically within the range you set for it. To hold in a range past the normal shift point for a few seconds, or to shift down for extra power, push the pedal all the way to the floor.

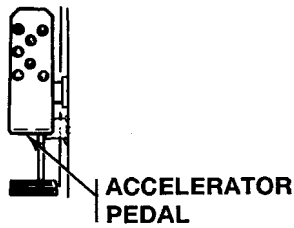

WARNING

Pressing lock buttons while carrier is moving can cause carrier brakes to lock up. You could hit another carrier or soldier. The buttons are strictly hands-off, except for parking.

CAUTION

The full-throttle transmission detent (pedal to the floor) is not a tradeoff for selecting the proper range. Use the detent for short bursts of power, not as a way to gear down for heavy hauling.

NOTE

Going in forward or reverse, the carrier will always turn toward the track that is moving slower.

7. Pull back on the left-hand steering lever to turn left.

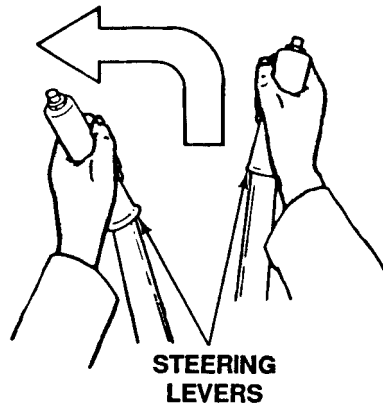

8. Pull back on the right-hand steering lever to turn right.

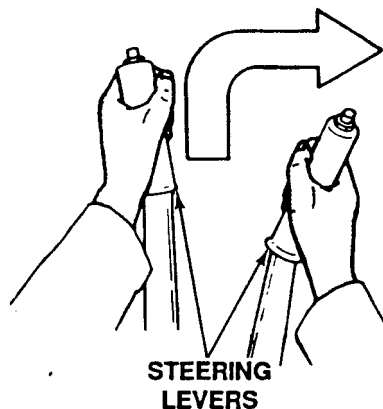

9. To slow the carrier, slowly pull both levers back.

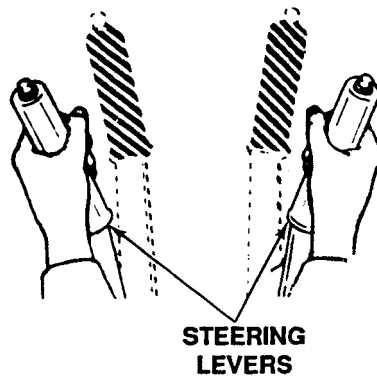

10. To stop the carrier, pull both levers at once using a pumping movement and remove your foot from the accelerator pedal.

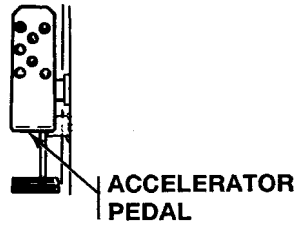

11. To lock the brakes for parking, pull back hard on both levers and press the lock buttons down.

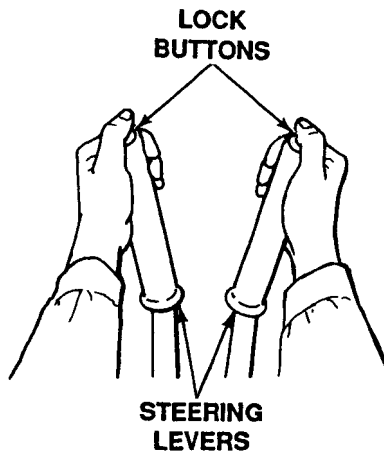

12. To unlock the brakes, pull back on the levers without touching the lock buttons. The buttons will pop up and release the levers.

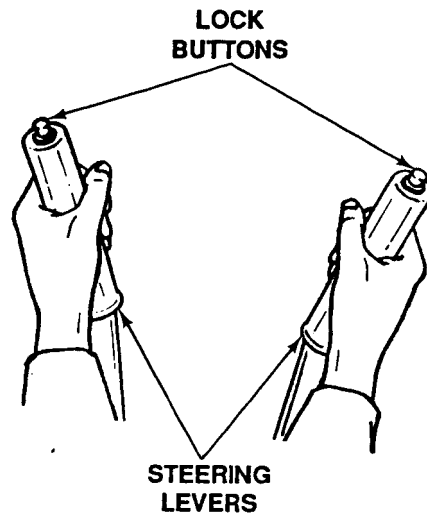

WARNING



Operating carrier in reverse is dangerous due to limited vision. Always post ground guides before you back up.

13. Shift transmission range selector to R range.

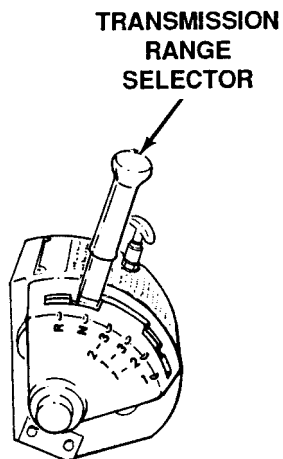

14. Pull back on the left-hand steering lever to turn left.

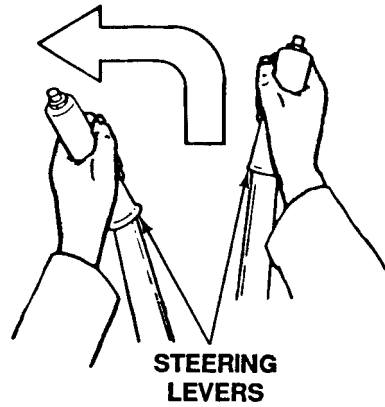

15. Pull back on the right-hand steering lever to turn right.

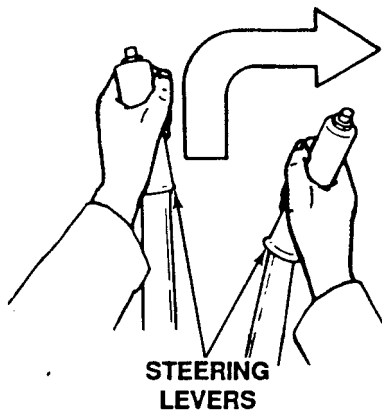

WARNING

You could get hurt by misuse of pivot steer. **NEVER** use the pivot steer brakes when you're moving except in an emergency. Never use the pivot steer brakes and differential brakes at the same time, you could injure yourself and damage the differential.

CAUTION

Avoid pivot steering on soft soil or gravel. Tracks may come off. After pivoting, drive ahead at least one carrier length to clear track.

Power plant can be damaged. Do not pivot steer when carrier is moving.

NOTE

Use pivot steer only when normal turns cannot be made in close areas. Stop carrier before making pivot steer.

The pivot steer brakes work like the differential brakes, only quicker because they are disk brakes. When you pull the handle, they lock up immediately.

16. Pull the left pivot steer lever handle to pivot left.
17. Pull the right pivot steer lever handle to pivot right.
18. Pull both handles to make a sudden stop from a slow speed.

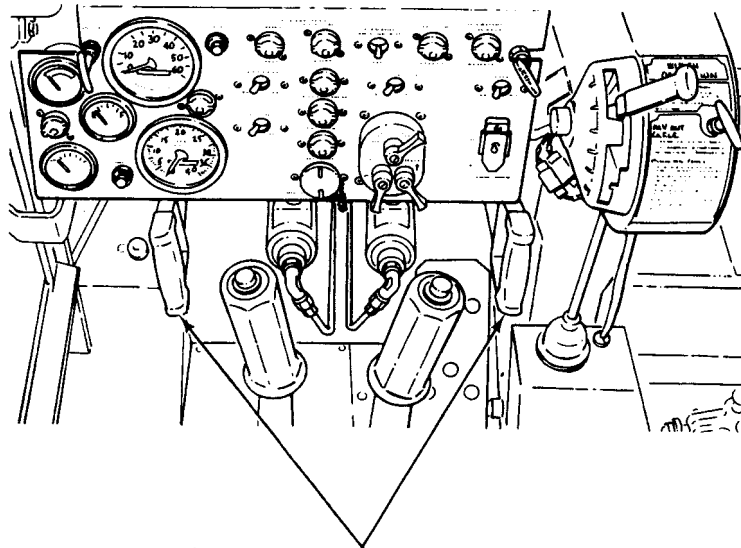

**PIVOT
STEER LEVER HANDLES**

SELECT DRIVING RANGE

1. Select driving range.

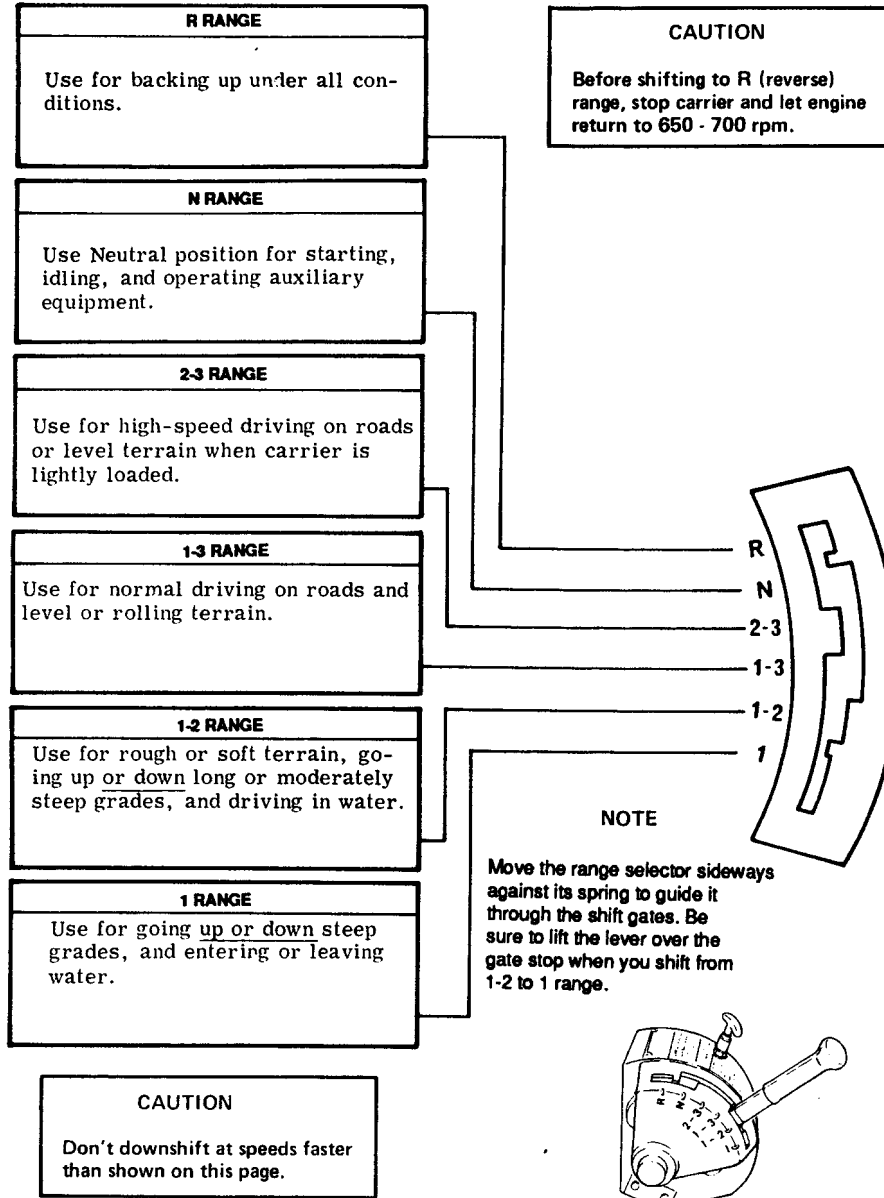

END OF TASK

DRIVE CARRIER (M548A3)

0021 00

THIS WORK PACKAGE COVERS:

Driving Precautions (page 0021 00-2).
Drive Carrier (page 0021 00-4).
Select Driving Range (page 0021 00-10).

INITIAL SETUP:

Maintenance Level

Operator

Equipment Condition

Engine started (WP 0014 00)

Personnel Required

Driver

DRIVING PRECAUTIONS

WARNING

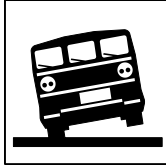

If a track carrier gets out of control and overturns, it is safer to stay in the carrier than to try to get out while the carrier is still moving. You may receive slight injuries from being thrown against metal parts; but if you try to leave the carrier, it may roll over and crush you. Once the carrier stops moving, get out as fast as possible because spilled fuel and oil may catch on fire. The first thing the driver should do in such an emergency is shut off the engine and turn off the master switch to minimize the fire hazard.

WARNING



If you break a track shoe or carrier throws a track, use extreme CAUTION to maintain carrier control. Immediately release accelerator and let carrier coast to a stop. Do not use brakes or steering controls unless you are about to enter a more hazardous situation.

1. Use 1-2 range until you get used to driving carrier.

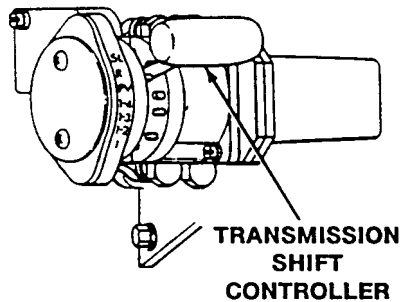

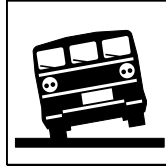
WARNING

Avoid oversteering at high carrier speeds to prevent skidding or carrier upset. Use caution when turning on hills or side slopes.

2. Take care not to oversteer or go too fast, especially on hard pavement. You could lose control of carrier.

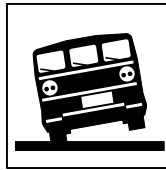
WARNING

Decelerate when carrier approaches brink of a trench or ditch and at a crest or on downgrade of a hill to avoid losing control of carrier and injury. Accelerate when carrier bottoms in a trench or ditch or when climbing a hill.

3. Slow down when you get to the top of a hill or the edge of a trench or ditch.
4. Use a low range (1 or 1-2) when driving down steep hills, and keep your speed down. Going down a trench or ditch, take care not to let the front of the carrier dig in at the bottom.

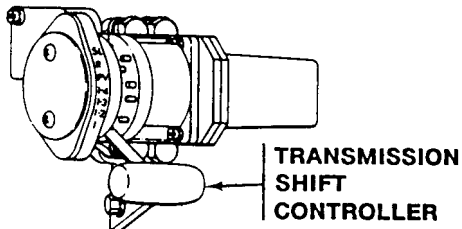

5. On loose sand, dirt, or rock, especially on side slopes, steer in several short turns to let track clear itself of rocks, dirt, branches, and other junk. In really heavy sand, mud, snow, or heavy growth, have unit maintenance take off track shrouds.
6. Don't use engine and transmission to hold carrier on a slope. Use brakes or block tracks with large rocks or logs.
7. Except in an emergency, don't use hand throttle for driving.

DRIVE CARRIER

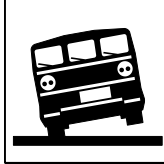
WARNING

If you break a track shoe or carrier throws a track, use extreme **CAUTION** to maintain carrier control. Immediately release accelerator and let carrier coast to a stop. Do not use brakes or steering controls unless you are about to enter a more hazardous situation.

WARNING

Brake pedal is very sensitive. Applying brake hard can cause carrier to stop suddenly. Personnel could be injured. Apply brake pressure lightly and with caution.

WARNING

Carrier movement can throw you from your seat and injure you. Use of seat belts is mandatory. See warning in front of manual.

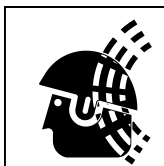
WARNING

Carrier noise can cause permanent hearing damage. Double hearing protection must be worn. See warning in front of manual.

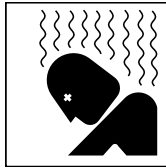
WARNING

Carrier operation during hot weather may result in heat stress to crew members. Crew members should limit their exposure to high temperature and humidity based on TB Med 507, using PHEL chart (Appendix C) curve as a guide.

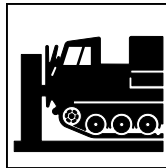
WARNING

Sticking or failed linkage can cause carrier crash. Personnel can be killed or injured. If accelerator pedal does not operate smoothly, or engine does not return to idle when accelerator pedal is released, do not drive carrier.

WARNING

Do not attempt to change carrier forward or reverse movement by shifting until carrier comes to a complete stop. Above 4 mph (6 km/hr), if you attempt to shift into reverse (or forward), the carrier will continue in the direction you are moving when you attempted to make the change. Failure to follow the above instructions could result in injury or death to personnel and destruction of equipment or property.

CAUTION

The crossdrive transmission in the M548A3 is designed not to change direction of movement at speeds above 4 mph (6 km/hr). If you attempt to shift into reverse while moving forward, above 4 mph (6 km/hr), the transmission will not go into reverse even with the transmission shift controller set to "R" (reverse), and the carrier will continue to move forward when you accelerate. Likewise, if you attempt to shift into a forward gear while moving above 4 mph (6 km/hr) in reverse, the carrier will continue to move in reverse when you accelerate.

1. Make sure cab and cargo compartment doors are closed and latched. Have all personnel fasten their seat belts.
2. START ENGINE (WP 0014 00).

3. Remove steering wheel lock pin securing steering wheel in center position.

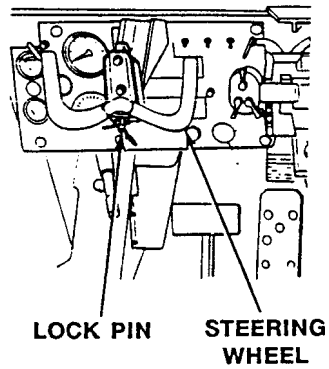

4. Place transmission shift controller in driving range needed (page 0021 00-10).

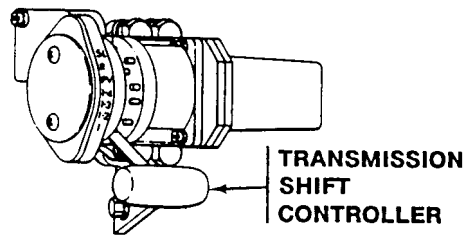

5. If tactical situation permits, press horn switch to sound horn and warn personnel that carrier is about to move.

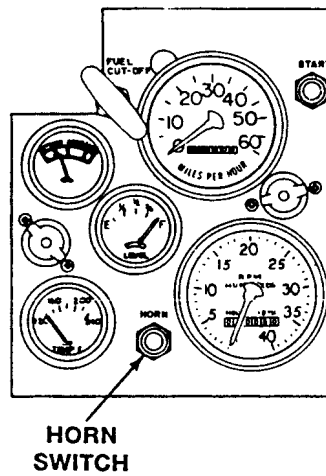

6. Step on brake pedal and push parking brake handle down to release parking brake.

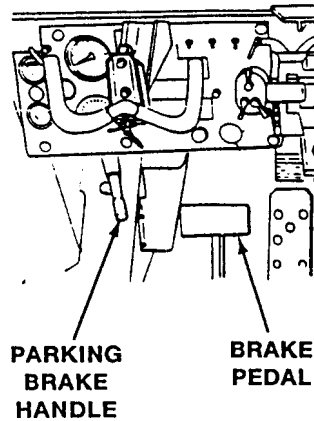

7. Press accelerator pedal slowly and evenly to obtain smooth carrier movement. Control speed and direction of carrier with accelerator pedal and steering wheel. The transmission will shift automatically within the driving range you selected.
8. Turn steering wheel to the left to turn carrier left when driving forward.

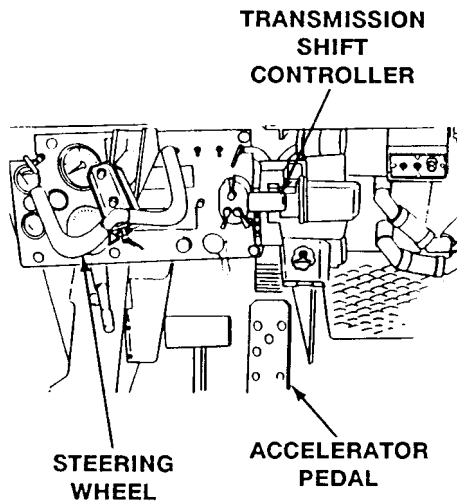

9. Turn steering wheel to the right to turn carrier right when driving forward.

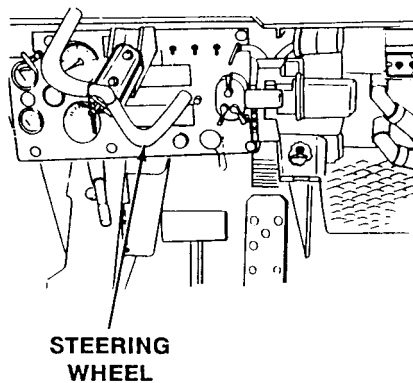

WARNING



Operating carrier in reverse is dangerous due to limited vision and reversed steering. Always post ground guides before you back up.

- 10. Place transmission shift controller in R position.
- 11. Turn steering wheel to the left to turn rear of carrier right when backing up.

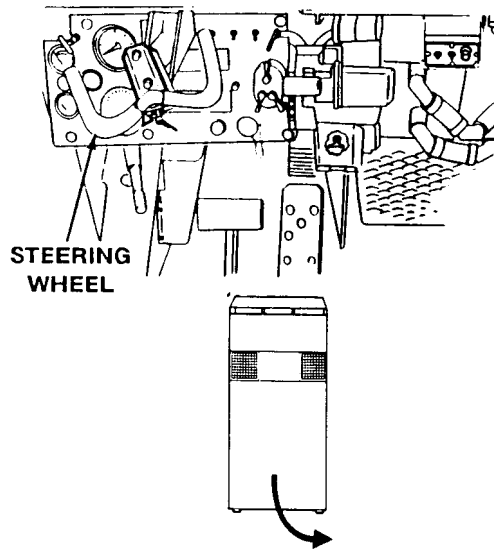

- 12. Turn steering wheel to the right to turn rear of carrier left when backing up.

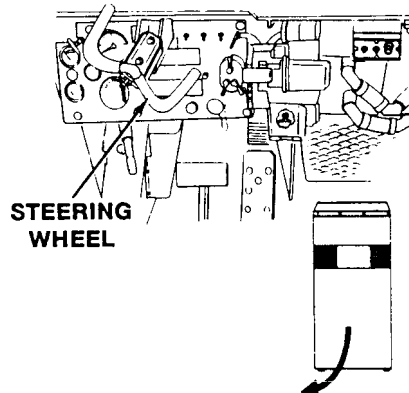

CAUTION

Use pivot steer only when normal turns cannot be made in close areas. Stop carrier before making pivot steer.

Power unit can be damaged. Do not pivot steer when carrier is moving.

Avoid pivot steering on soft soil or gravel. Track may come off. After pivoting, drive ahead at least one carrier length to clear track.

13. Place transmission shift controller in PV position.

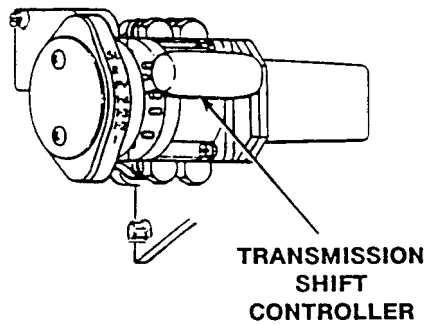

14. Turn steering wheel to the left and press accelerator pedal to pivot carrier left.

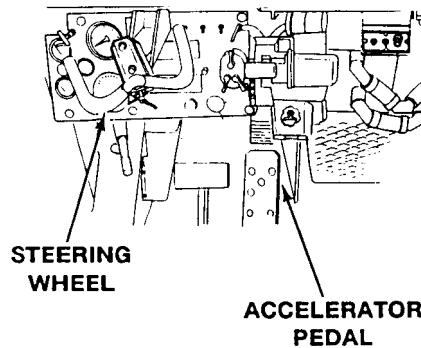

15. Turn steering wheel to the right and press accelerator pedal to pivot carrier right.

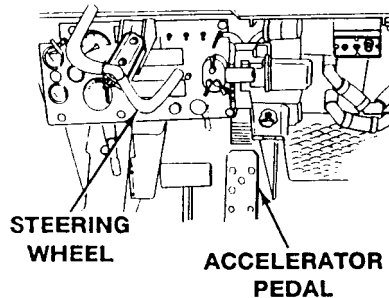

- To stop carrier, press down on brake pedal with smooth, gradual pressure.

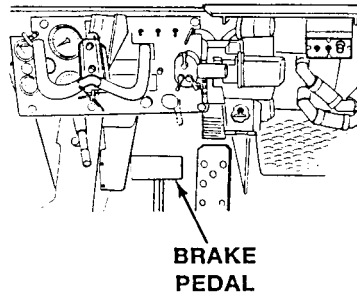

SELECT DRIVING RANGE

NOTE

Move the transmission shift controller sideways against its spring to guide it through the shift gates.

- SL (steering lock) position range is for locking steering wheel in center position. Used during starting, idling and engine shut down.

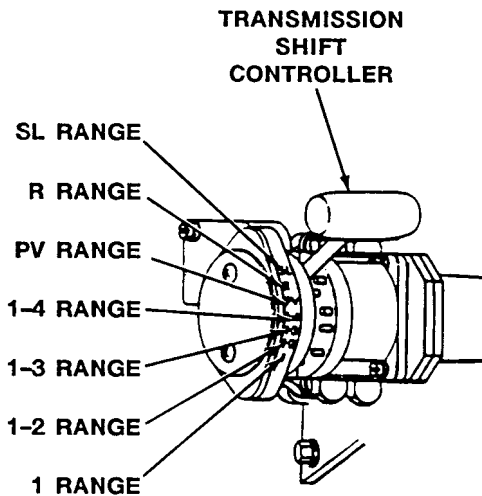

CAUTION

Before shifting to R (reverse) position, stop carrier and let engine return to 600–650 rpm.

CAUTION

Avoid prolonged engine idling. This causes coolant temperature to drop below operating temperature and is detrimental to the life of the engine. Engine should be run at 1,000 to 1,200 rpm under no-load conditions for prolonged idle.

- R RANGE (reverse) range is used for reversing the carrier in both water and on land. R range can also be used to slow the carrier when drifting forward.

3. PV RANGE (pivot vehicle) is used for pivot steering.
4. 1-4 RANGE is used for high-speed driving on roads or level terrain.
5. 1-3 RANGE is used for driving on slight grades, high-speed cross country, and moderate speed road travel. Shifting down will occur at speeds below 25 mph (40 km/hr).
6. 1-2 RANGE is used for rough or soft terrain, going up or down long or moderately steep grades, and water travel. Shifting down will occur at speeds below 15 mph (24 km/hr).
7. 1 RANGE is used for going up or down steep grades, and entering or leaving water. Shifting down will occur at speeds below 6 mph (10 km/hr).

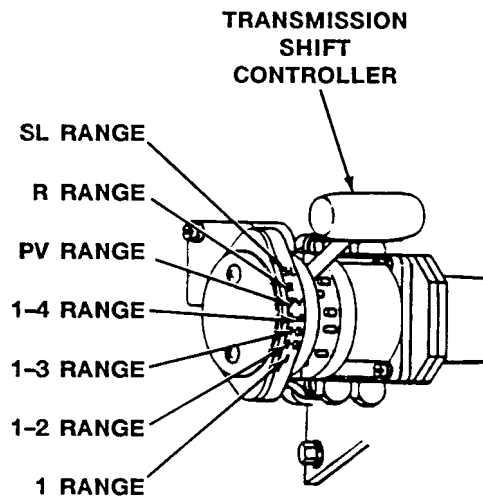

END OF TASK

OPERATE TURN SIGNAL KIT

0022 00

THIS WORK PACKAGE COVERS:

Operation (page 0022 00-1).

INITIAL SETUP:

Maintenance Level

Operator

Equipment Condition

Engine started (WP 0013 00), (WP 0014 00)

Personnel Required

Driver

OPERATE TURN SIGNAL KIT

NOTE

Turn signal and hazard warning lights flash. Lights work only when main light switch is set to service drive or service stop light.

1. Move control lever down to signal a left turn or up to signal a right turn.
2. To use hazard warning, push hazard tab back and move control lever past right turn signal position as far as it will go. A light in the center of the control will flash with signal lights and stop lights to let you know that you're signaling.
3. When you have completed your turn or the hazard warning is no longer required, move control lever back to neutral position by hand.

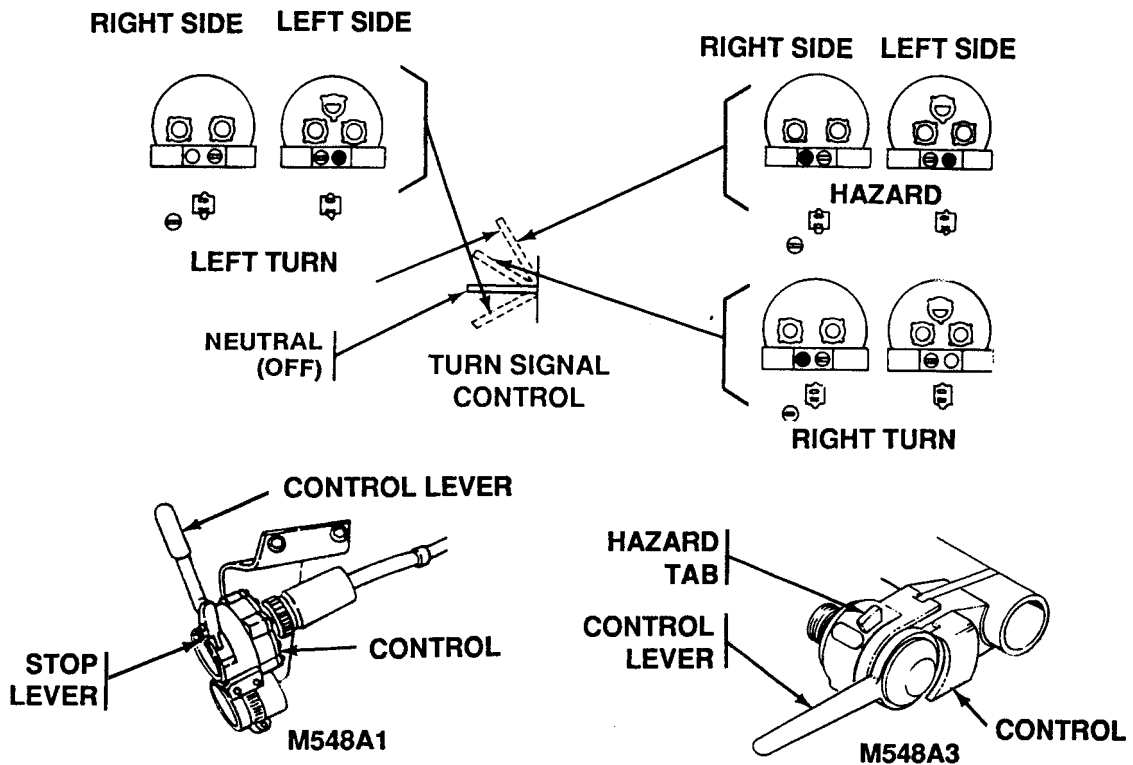

END OF TASK

STOP ENGINE (M548A1)

0023 00

THIS WORK PACKAGE COVERS:

Stop Engine (page 0023 00-1).

INITIAL SETUP:

Maintenance Level

Operator

Equipment Condition

Engine started (WP 0013 00)

Personnel Required

Driver

STOP ENGINE

1. Pull back the differential steering and braking levers and press down the brake lock buttons to lock the differential brakes.

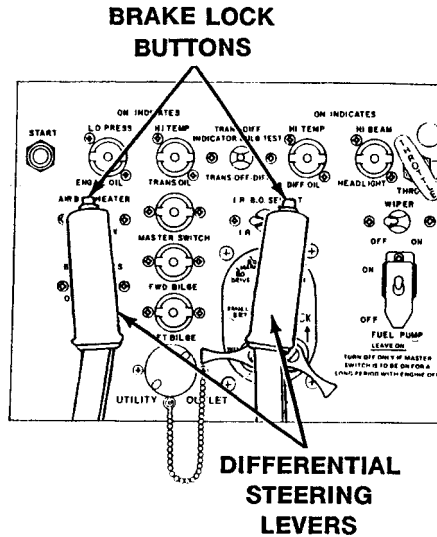

2. Place the transmission range selector in N position.
3. Set the engine to run at about 1,000 rpm for 2 minutes or so.
4. Set the engine back to idle (650–700 rpm) and check the instrument panel for normal readings.
5. Pull the fuel cut-off all the way out. The engine will stop when it has burned all the fuel in its injectors and feed lines. (This should only take a few seconds.)

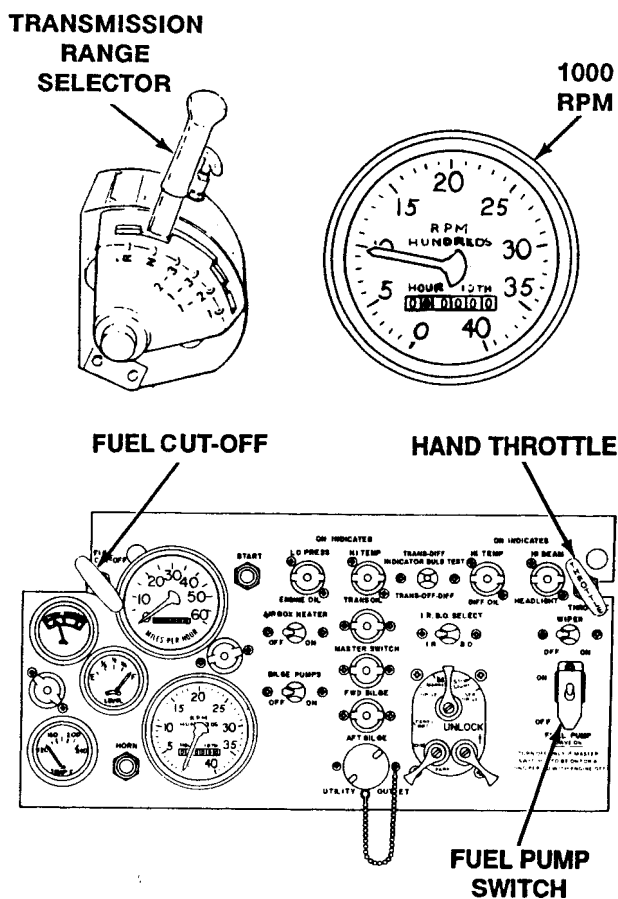

CAUTION

Always shut the engine off before you turn the MASTER SWITCH OFF. If you turn the MASTER SWITCH OFF with the engine running, you may damage the generator or regulator.

6. Turn off the lights, radio, and any other electrical equipment that's on. If you have a vehicle compartment heater kit that's been running, wait for the heater to complete its cool-down and stop itself after you turn it off. The light will go off when the heater blower stops.

7. Turn the MASTER SWITCH OFF. If you have to leave the MASTER SWITCH ON for a long time while the engine isn't running, lift the guard and turn the FUEL PUMP switch OFF.

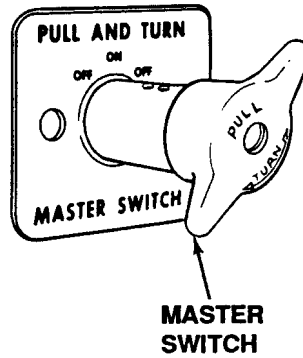

END OF TASK

STOP ENGINE (M548A3)

0024 00

THIS WORK PACKAGE COVERS:

Stop Engine (page 0024 00-1).

INITIAL SETUP:

Maintenance Level

Operator

Equipment Condition

Engine started (WP 0014 00)

Personnel Required

Driver

STOP ENGINE

1. Bring carrier to a complete stop.
2. Place transmission shift controller in SL (steering wheel lock).
3. Set parking brake by pushing on brake pedal and then pull up on parking brake handle.

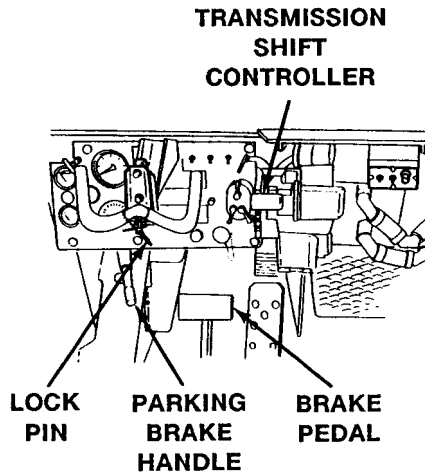

WARNING

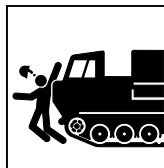

Carrier can pivot steer when engine is running, transmission is in SL (steering wheel lock), and steering wheel is unlocked. This could cause injury or death to personnel. Lock steering wheel before leaving carrier. Do not grab steering wheel when entering or leaving cab.

4. Lock steering wheel in center position using steering wheel lock pin.

CAUTION

Turbo may be damaged by heat if engine is immediately stopped after long periods of operation. Allow engine to run at idle speed (600–650 rpm) for 3–5 minutes before stopping.

In hot weather, do not stop engine until engine coolant temperature is at 185°F (85°C) or lower.

- Change rpm from 600–650 to 1,000–1,200 rpm for 3 to 5 minutes. Return engine to idle speed (600–650 rpm).

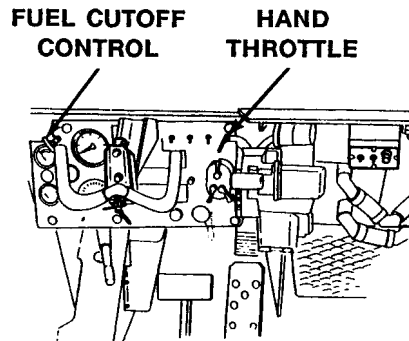
**CAUTION**

Regulator may be damaged if you turn MASTER SWITCH OFF with engine running. Make sure engine has stopped before turning MASTER SWITCH OFF.

- Pull fuel cutoff control all the way out to stop engine.

NOTE

If temperature is below -25°F (-32°C), start engine coolant heater. See task; OPERATE ENGINE COOLANT HEATER KIT (M548A3) (WP 0041 00).

- Turn the MASTER SWITCH OFF.

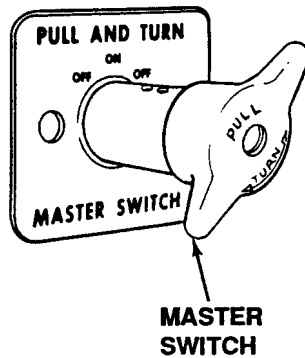

END OF TASK

FUEL CARRIER

0025 00

THIS WORK PACKAGE COVERS:

Fuel Carrier (page 0025 00-1).

INITIAL SETUP:

Maintenance Level

Operator

Personnel Required

Driver

Materials/Parts

Wiping Rag (WP 0083 00, Item 16)

Equipment Condition

Engine stopped (WP 0023 00), (WP 0024 00)

FUEL CARRIER

WARNING



Fuel can catch fire and burn you. Do not smoke or allow open flame near carrier when fueling.

1. Attach carrier fueling ground wire to bare metal on carrier to be fueled.

CAUTION

Contamination can damage fuel system. Remove dirt and water from fuel filler area before opening fuel filler cap.

2. Clean off dirt and water that could get into filler neck. Use rag.
3. Unscrew the filler cap.
4. Check screen in filler neck for damage. Remove any dirt and debris. Put screen back before you fuel. Notify unit maintenance if screen is damaged.

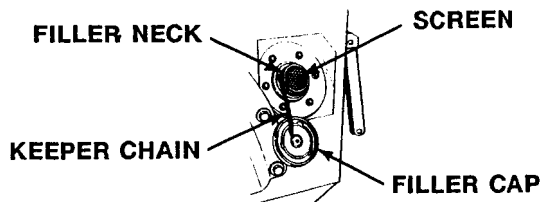

WARNING

Sparks from static electricity can cause a fire or explosion. Metal nozzle must touch metal in fuel filler neck when fuel is running.

5. Fill up. Make sure you have metal to metal contact between fuel nozzle and filler neck.
6. Leave a few inches air space in filler neck in case the fuel expands if carrier is to be parked after fueling.
7. Take fuel nozzle out after fueling and screw on filler cap. Be sure keeper chain is all inside so filler cap goes on tight.
8. Disconnect ground wire.

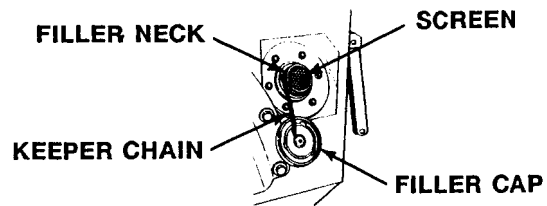

END OF TASK

INSTALL/REMOVE AIR INTAKE AND EXHAUST GRILLE COVERS (M548A1)

0026 00

THIS WORK PACKAGE COVERS:

Install Covers (page 0026 00-1).
 Remove Covers (page 0026 00-3).

INITIAL SETUP:

Maintenance Level

Operator

Equipment Condition

Carrier stopped

Personnel Required

Soldier

INSTALL COVERS

CAUTION

Engine can overheat. Open center flap before starting engine. Do not operate engine with covers installed except in cold environment (below -25°F).

NOTE

Use covers whenever engine coolant heater kit is operated or when parked to keep dust, sand, or rain from engine compartment.

1. Lift air intake grille, slide air intake grille cover over grille, and snap cover flaps. Lower grille.

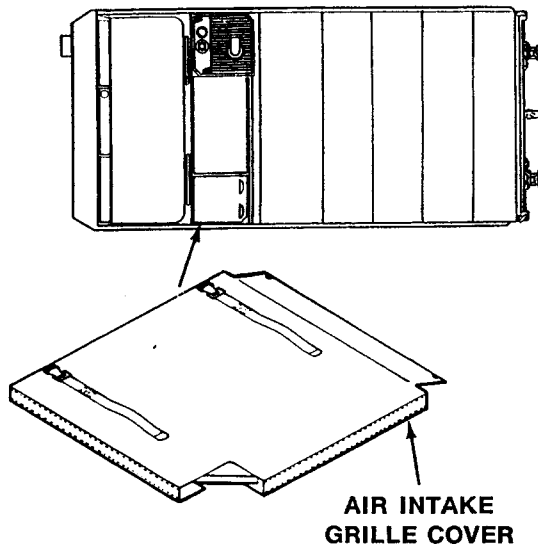

NOTE

Exhaust grille cover has a slit so that it can be installed on exhaust grille without lifting grille clear of exhaust pipe.

2. Unsnap slit on exhaust grille cover.
3. Lift exhaust grille, slide exhaust grille cover over grille, and snap cover flaps and exhaust pipe slit. Lower grille.

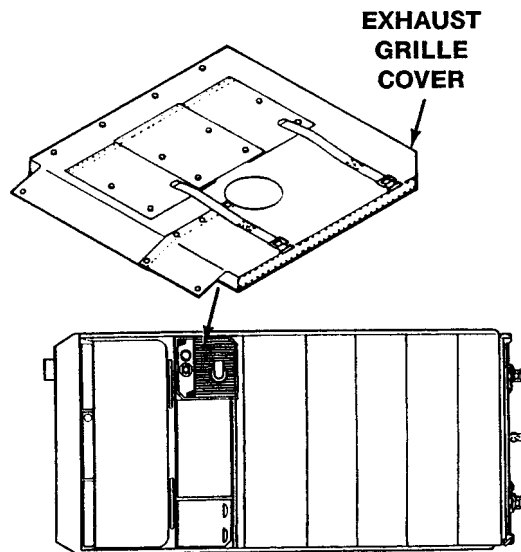

REMOVE COVERS

1. Lift exhaust grille, unsnap cover flaps and exhaust pipe slit, and slide exhaust grille cover from grille. Lower grille.
2. Lift air intake grille, unsnap cover flaps and slide air intake grille cover from grille. Lower grille.
3. Stow air intake and exhaust grille covers in cab.

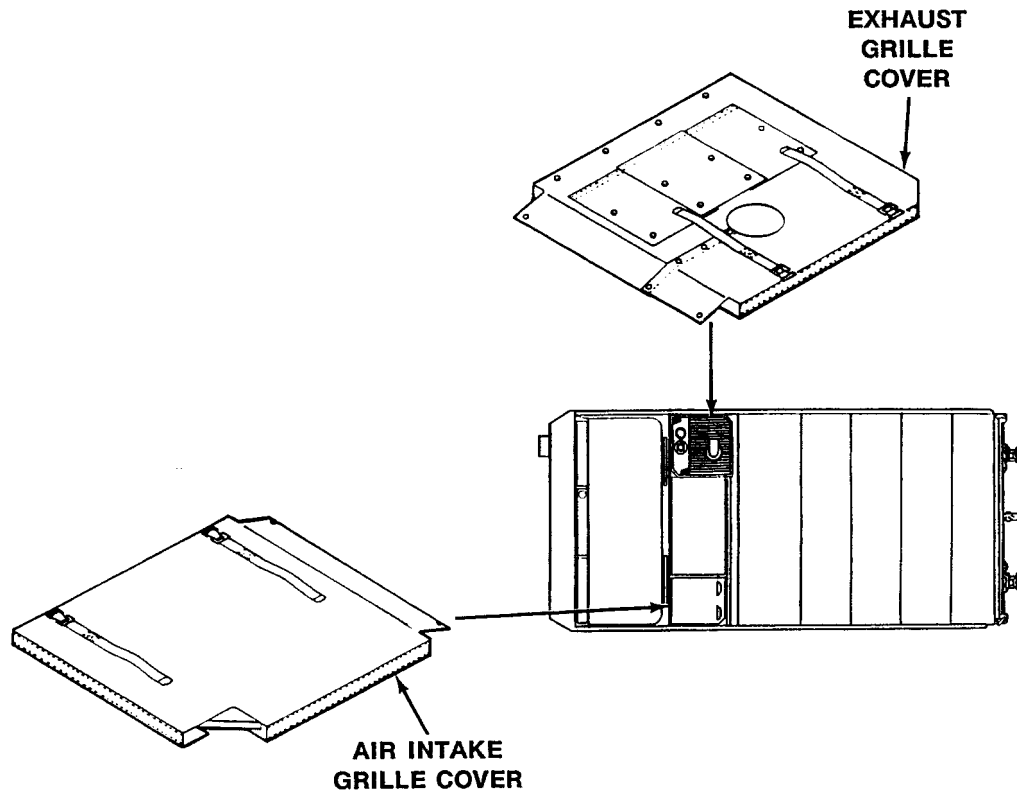
**END OF TASK**

INSTALL/REMOVE AIR INTAKE AND EXHAUST GRILLE COVERS (M548A3)

0027 00

THIS WORK PACKAGE COVERS:

Installation (page 0027 00-1).
Removal (page 0027 00-2).

INITIAL SETUP:

Maintenance Level

Operator

Equipment Condition

Engine stopped (WP 0024 00)

Carrier blocked (WP 0038 00)

Personnel Required

Driver

Soldier

INSTALLATION

NOTE

The grille covers are the same and will fit over either grille.

1. Remove air intake and exhaust grilles.
2. Secure the covers over the grilles with two snaps and a strap.
3. Install air intake and exhaust grilles.

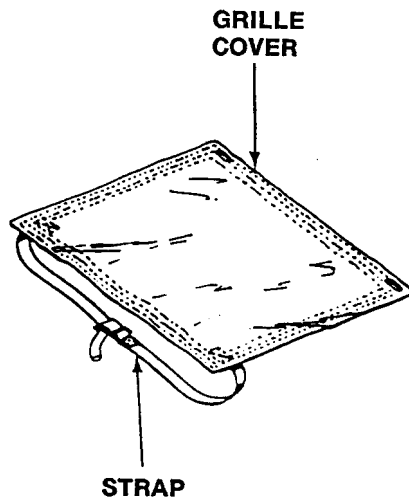

REMOVAL**NOTE**

If it's really cold, you can use the air intake grille cover to restrict cooling air flow and speed engine warm up. Leave cover over grille, but not so it covers grille completely. When engine warms up to about 160°F (71°C), remove and stow grille cover.

1. Remove air intake and exhaust grilles.
2. Loosen strap and two snaps and remove covers from grilles. Secure straps and stow grille covers near tool bag.
3. Install air intake and exhaust grilles.

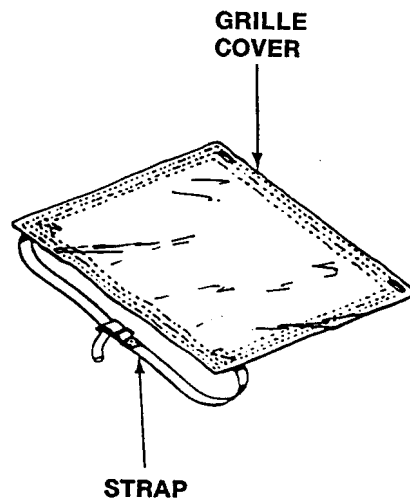
**END OF TASK**

OPERATE AIR BRAKE KIT (M548A1)

0028 00

THIS WORK PACKAGE COVERS:

Operation (page 0028 00-1).

INITIAL SETUP:

Maintenance Level

Operator

Personnel Required

Driver (2)

Equipment Condition

Engine stopped (WP 0023 00)

Carrier blocked (WP 0038 00)

OPERATE AIR BRAKE KIT

1. Connect towed load to carrier pintle (WP 0048 00).
2. Connect towed load safety chains to towing eyes on carrier tailgate.
3. Unstrap service and emergency air couplings from their stowed position on cargo compartment door (M548A1 carriers with air brake kit).

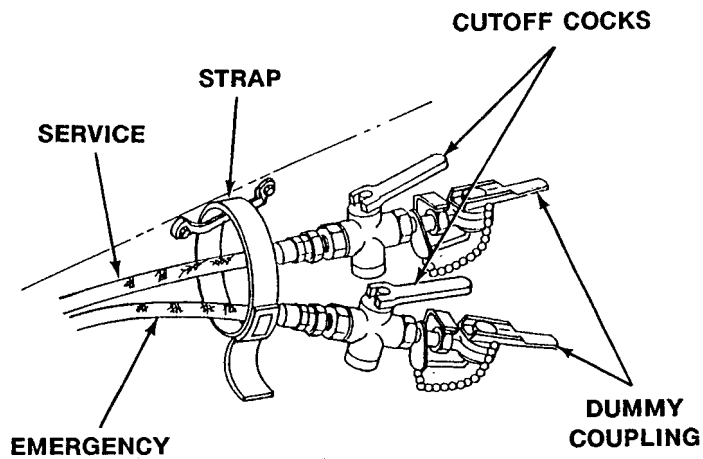

CAUTION

Make sure you connect the air couplings; SERVICE to SERVICE and EMERGENCY to EMERGENCY.

4. Remove two dummy couplings. Connect carrier service and emergency air couplings to towed load service and emergency air couplings.
5. Turn two air cutoff cocks at right angles to their air hoses. In this position, the cocks are open.

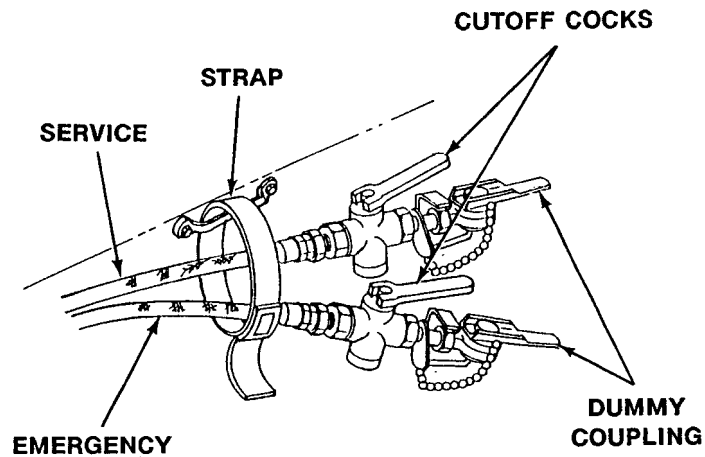
**CAUTION**

If pressure drops below 60 psi (8.7 kPa) or LOW PRESSURE warning light comes ON while you're driving stop and fix problem.

6. After starting carrier engine, make sure air pressure gauge reaches 85 psi (12.3 kPa) before you drive carrier with a towed load. LOW PRESSURE warning light must go OFF.
7. To slow or stop carrier, step on treadle valve pedal just before you apply differential brakes.

8. To disconnect towed load use following steps.
 - a. Turn two air cutoff cocks in line with their air hoses (closed).
 - b. Disconnect two carrier air couplings from two towed load air couplings. Install two dummy couplings.
 - c. M548A1 carrier, secure two air couplings to cargo compartment door with strap.

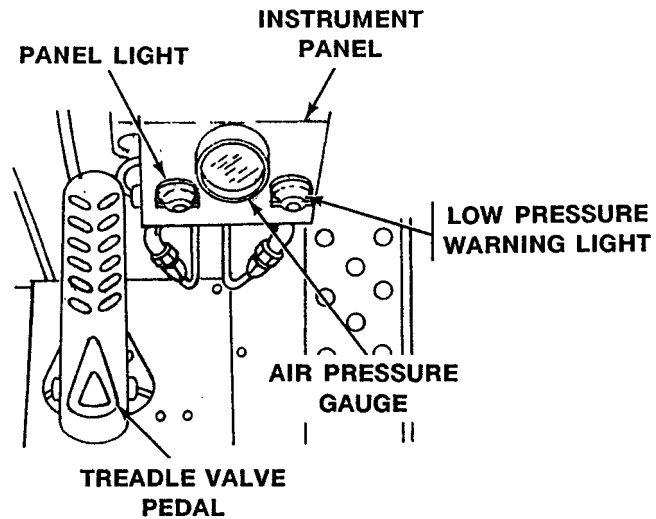

9. Disconnect safety chains from towing eyes on tailgate.
10. Disconnect towed load from carrier pintle (WP 0048 00).

END OF TASK

OPERATE MATERIAL HANDLING KIT

0029 00

THIS WORK PACKAGE COVERS:

- Adjust Hoist (page 0029 00-1).
 - Use Hoist (page 0029 00-3).
 - Prepare Hoist for Travel (page 0029 00-4).
-

INITIAL SETUP:

Maintenance Level

Operator

Equipment Condition

Engine stopped (WP 0023 00), (WP 0024 00)
Carrier blocked (WP 0038 00)

Personnel Required

Driver (2)

ADJUST HOIST

1. Loosen two hoist beam locks and slide beam to a full-forward position for travel or full-rear position for loading.
2. Tighten two hoist beam locks to hold beam in place.

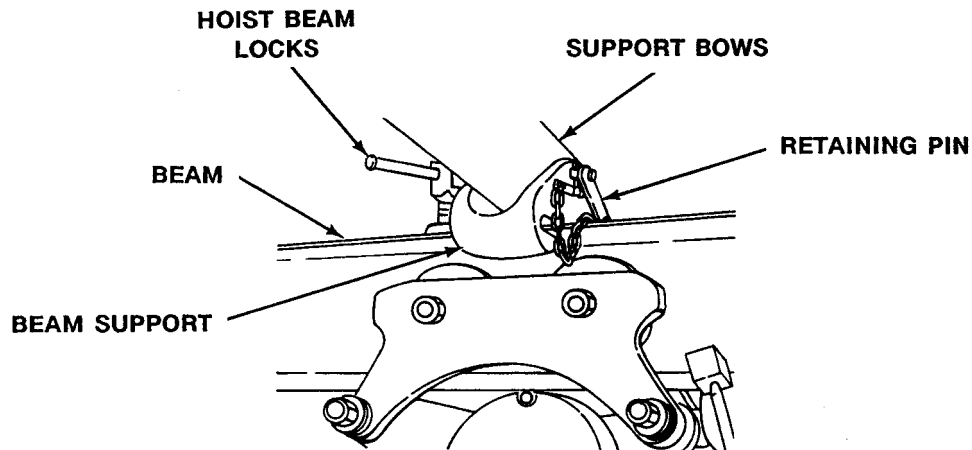

3. Move beam to side position you choose.
 - a. Beam supports may be positioned in any of three holes in each support bow.
 - b. Each beam may be set up in one of seven positions shown.

- c. One hoist beam lock must be loosened to go from a straight position to a slant position or to return to a straight position. Seven beam positions are shown.

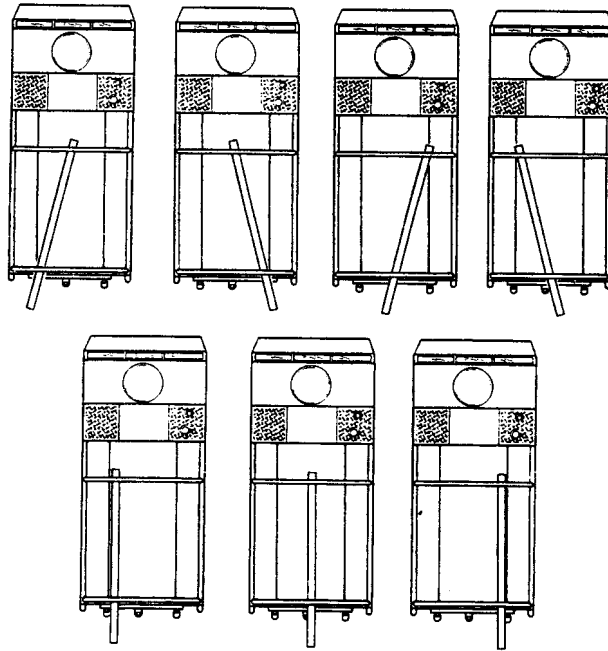

CAUTION

When you install the beam, make sure the beam stops are in front of the rear beam support and beam locks are toward the front.

4. To move a beam support.
- Hold beam up by hand. Turn handle of support retaining pin up. Pull pin out.
 - Line up support with the hole you want in support bow.
 - Install support retaining pin through support and bow. Turn pin handle down to secure pin.

USE HOIST

1. Remove stowage strap and unstow chains.
2. Release trolley lock and position hoist over load.

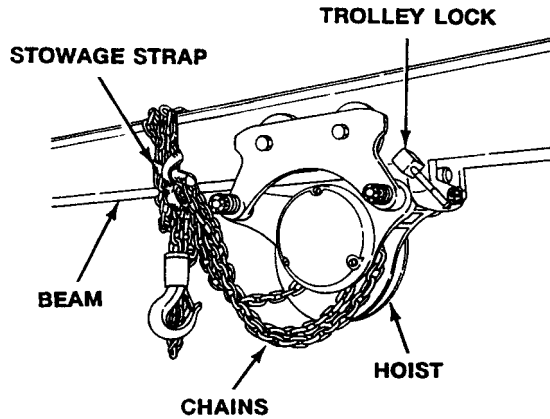

3. Wrap two web slings around load for secure hoisting.
4. Use hand chain to lower load chains to connect load chain hook to slings.
5. Use hand chain to raise load clear of loading surfaces. Then move the hoist with the load to where you want it.
6. Use hand chain to lower load. Disconnect hook on load chain from slings. Remove slings from load.

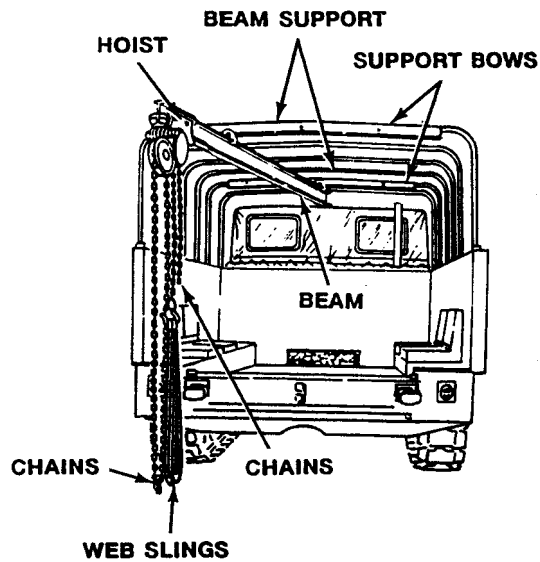

PREPARE HOIST FOR TRAVEL

1. Secure trolley lock.
2. Move beam supports to center position, if they are not there.

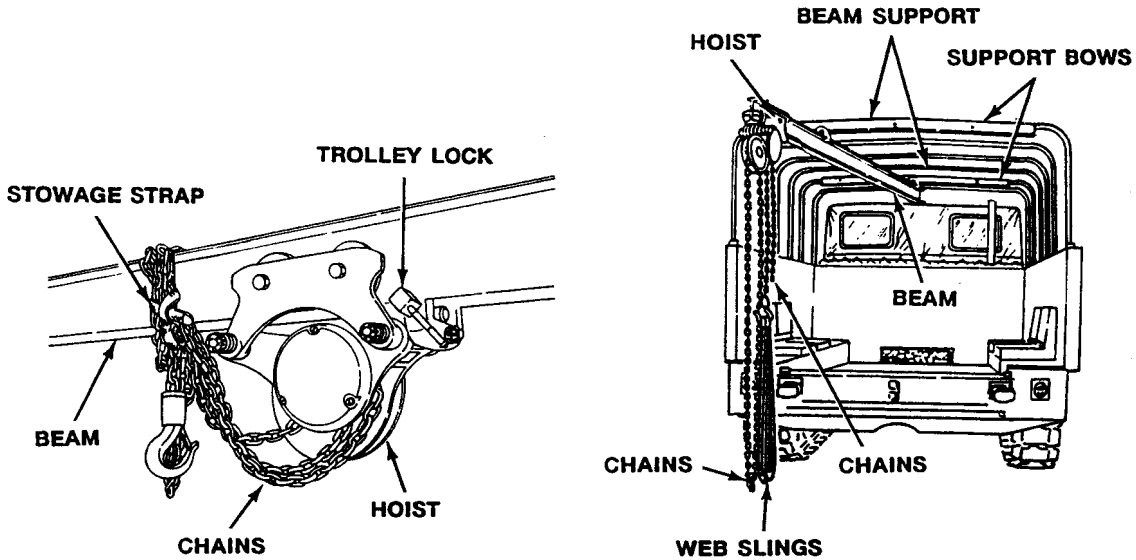

3. Loosen both beam locks. Move beam to full-forward position. Secure beam locks.
4. Release the trolley lock. Move the hoist to rear end of beam. Secure trolley lock.
5. Secure chains to beam or support bow with strap.

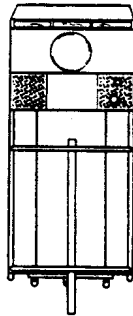

END OF TASK

OPERATE WINCH (M548A1)

0030 00

THIS WORK PACKAGE COVERS:

- Reel Out Wire Rope (page 0030 00-1).
- Reel In Wire Rope (page 0030 00-3).
- Wind Wire Rope (page 0030 00-5).

INITIAL SETUP:

Maintenance Level

Operator

Equipment Condition

Engine stopped (WP 0023 00)

Personnel Required

- Driver
- Soldier

REEL OUT WIRE ROPE

WARNING

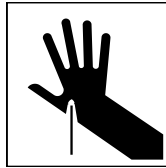

Rusty or broken wires can hurt you badly. Wear gloves whenever you handle the winch wire rope. Never let wire rope run through your hands.

1. Move the drum lock to the unlocked position.
2. Slack off on the wire rope so you can disengage the winch drum clutch.
 - a. Raise cab center floor plates (WP 0077 00).
 - b. Turn winch transfer gearcase hex nut clockwise.

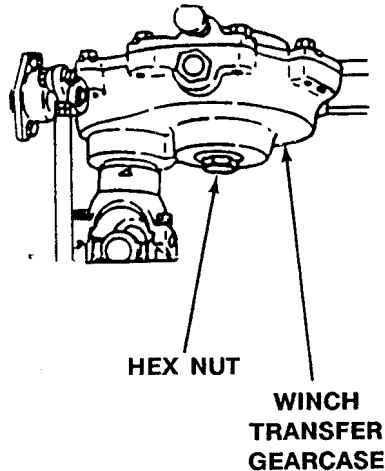

3. Pull out the clutch handle lock and move the drum clutch handle to disengaged position.

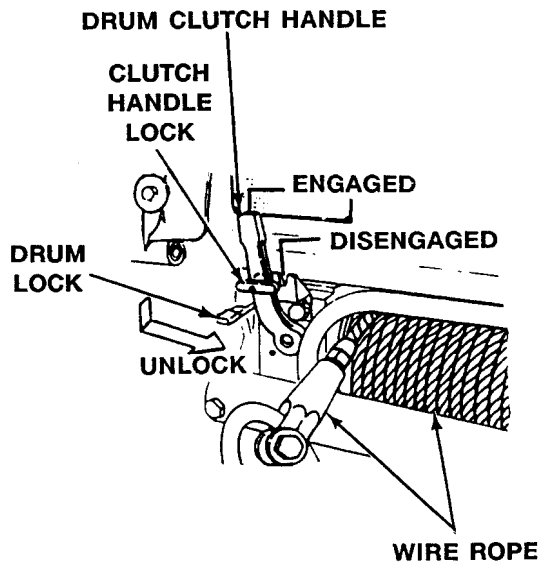

NOTE

As you operate the winch, check for grabbing or excessive play in the drum lock and clutch handle. If you notice anything wrong, report the problem to unit maintenance.

Always leave at least four turns of wire rope on the winch drum.

4. Pull out the wire rope by hand.
5. Secure the wire rope to a suitable anchor point. A snatch block and utility chain are stowed under the water can in the cab. You can use them to help secure the rope to the anchor point. Pick an anchor point as nearly straight in front of the carrier as you can so the rope will wind on the drum smoothly.

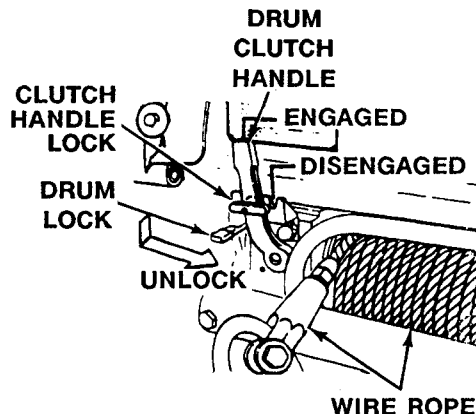

REEL IN WIRE ROPE

WARNING



If the winch wire rope snaps, it could injure or kill you. Keep clear of the winch wire rope while the winch is running.

1. Pull out the clutch handle lock and move the drum clutch handle to engaged position. Check that the drum lock is in unlocked position. If the clutch handle doesn't move easily, turn the drum a little by hand.

NOTE

The winch won't run with the carrier stopped and in gear.

2. Lock the differential brakes. Place the transmission range selector in N range. Run engine at 650–700 rpm.

NOTE

If the power takeoff gears don't engage, push the control in and repeat Step 2 and Step 3.

3. Place the transmission range selector in 2-3 range. Pull out the winch power takeoff control.

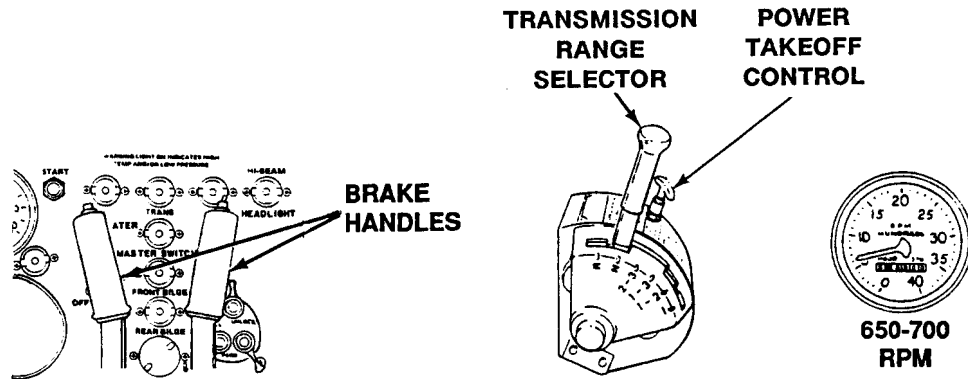

4. Release the differential brakes. Push down the accelerator pedal nice and easy so the winch runs smoothly at a moderate speed.
5. If you need extra power, place the transmission range selector in 1 range.

6. To stop the winch; place transmission range selector in 2-3 range, run engine at idle rpm, lock the differential brakes, and push in power takeoff control.

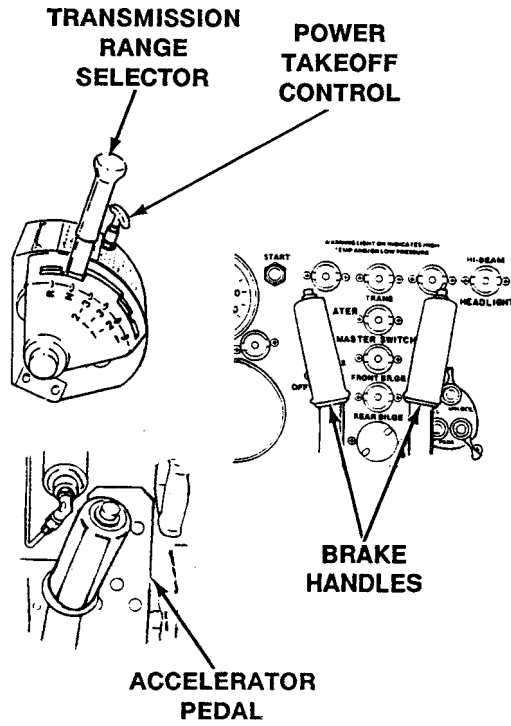

WIND WIRE ROPE

NOTE

If the wire rope isn't wound on the drum smoothly after you have used the winch, go to next step.

1. Reel out and anchor the wire rope.

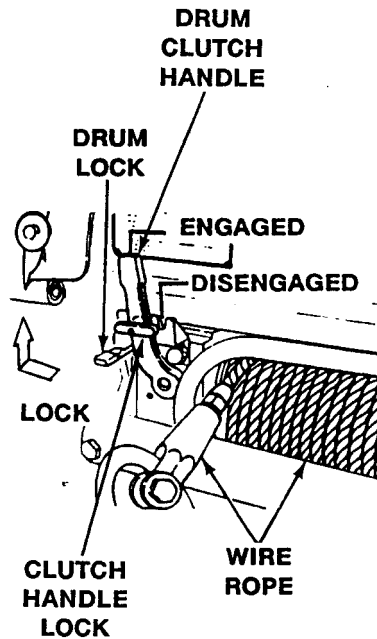

NOTE

Use a block of wood to encourage the first layer of wire rope to wind smoothly on the drum. If necessary, pound the wire rope into place.

2. Reel in the wire rope, towing the carrier over level ground.
3. Stow the hook and chain.
4. Lock the drum lock.
5. Inspect the wire rope to make sure it is in good condition. If it is frayed or broken, notify unit maintenance of damage.

END OF TASK

OPERATE VEHICLE COMPARTMENT AND CARGO HEATER

0031 00

THIS WORK PACKAGE COVERS:

- Operate Heater (page 0031 00-1).
- Operate Heat Manifold Control (M548A1) (page 0031 00-2).
- Operate Heat Regulator Control (page 0031 00-3).
- Operate Defroster Fans (page 0031 00-3).

INITIAL SETUP:

Maintenance Level

Operator

Equipment Condition

MASTER SWITCH ON

Personnel Required

Driver

OPERATE HEATER

1. Make sure the MASTER SWITCH is ON, and look to make sure nothing is blocking the heater exhaust.

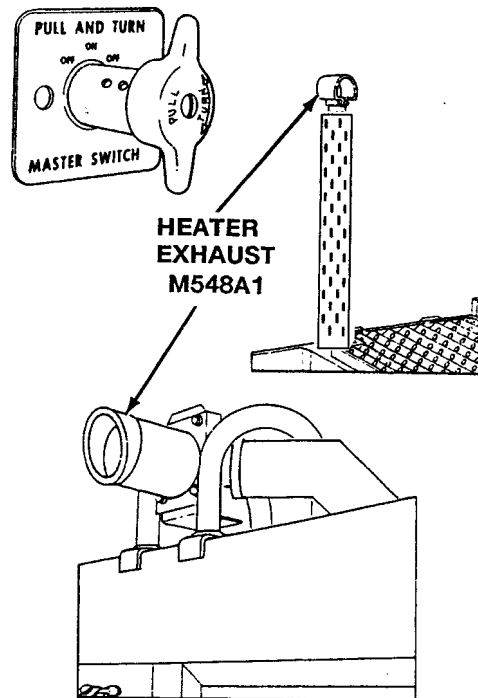

2. Press the indicator light housing. If the light glows, you know you have power to the heater controls. If the light doesn't glow when you press the housing, troubleshoot the heater (WP 0055 00).

3. Hold the RUN-OFF-START switch until the indicator light comes on. Then move the switch straight to RUN without stopping in OFF position.

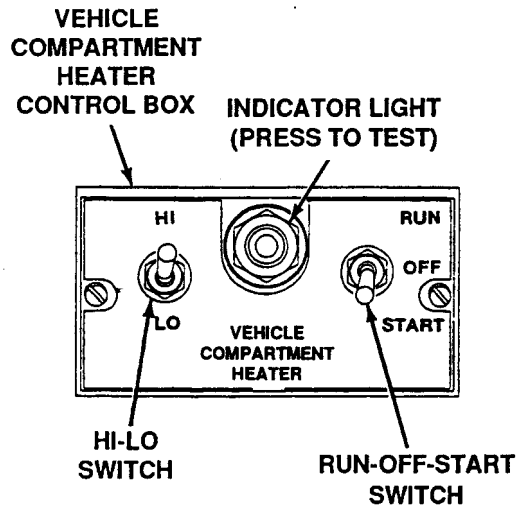

NOTE

When using DF-2 fuel, set the HI-LO switch on HI only, and run for 1-3 minutes before switching to LO.

4. Select the high or low heat with the HI-LO switch. The heater will always start on low heat no matter how the HI-LO switch is set, and will go to high after it starts if the switch is at HI.
5. If the heater doesn't start, try again. If it doesn't start in three tries, troubleshoot heater (WP 0055 00).
6. Move the RUN-OFF-START switch to OFF to turn the heater OFF. The heater will stop burning right away, but the blower will run until the heater cools off.

OPERATE HEAT MANIFOLD CONTROL (M548A1)

1. Move the control handle to the rear stop to direct warm air into the lower cab area.

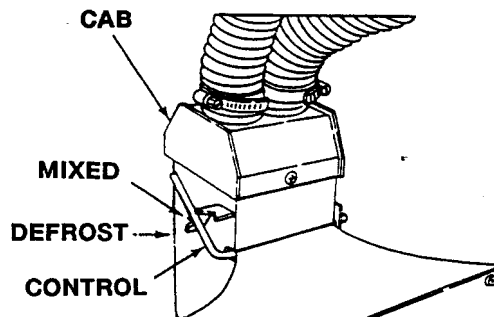

2. Move the control handle to the front stop to direct air through the defroster slots onto the windshield.

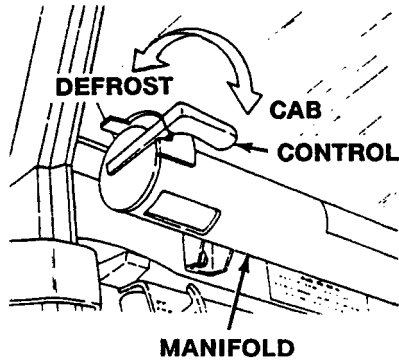

OPERATE HEAT REGULATOR CONTROL

1. Move the heat regulator control all the way up to direct warm air into the cab.
2. Move the control all the way down to direct warm air through the defrosters onto the windshields.
3. Place the control in the middle position to direct warm air through all ducts.

OPERATE DEFROSTER FANS

CAUTION

In cold temperatures, defroster heat can crack windshields. Cracking is caused by the difference in temperature between the inside and outside surfaces. Use defrosters just enough to keep the windshields clear.

1. Two defroster fan switches are located just to the left of the vehicle compartment heater control box. The right switch controls the fan which supplies cab air to the right defroster duct. Turn the switches OFF when defrost air is not required. (You don't have to worry about cracking the windshield with this kit.)

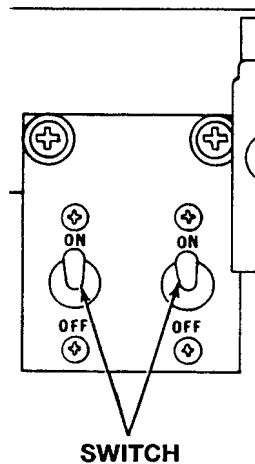

END OF TASK

OPERATE CARRIER LIGHTS

0032 00

THIS WORK PACKAGE COVERS:

- Operate Headlights (page 0032 00-1).
- Operate Blackout Marker (page 0032 00-3).
- Operate Blackout Marker and Blackout Driving Lights (page 0032 00-4).
- Operate Stop Light (page 0032 00-5).
- Operate Infrared Headlights (page 0032 00-5).
- Operate Panel and Transmission Controller Lights (page 0032 00-6).

INITIAL SETUP:

Maintenance Level

Operator

Equipment Condition

MASTER SWITCH ON

Personnel Required

Driver

OPERATE HEADLIGHTS

1. Move LIGHTS UNLOCK switch to UNLOCK, and hold.
2. Move PANEL AND TRANSMISSION CONTROLLER LIGHTS switch to OFF.
3. Move DRIVING LIGHTS switch to SER DRIVE.

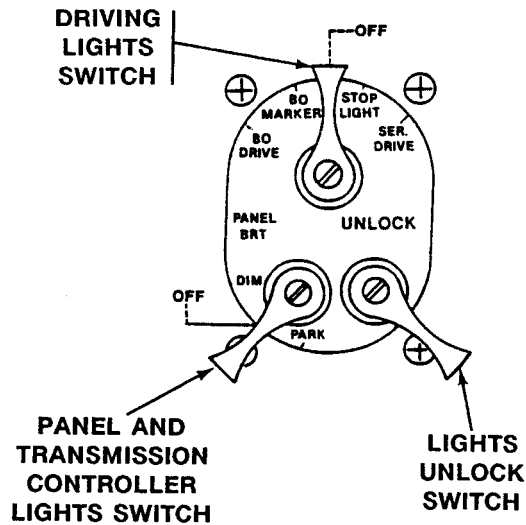

4. Press HEADLIGHT BEAM SELECTOR switch for HIGH or LOW beam.

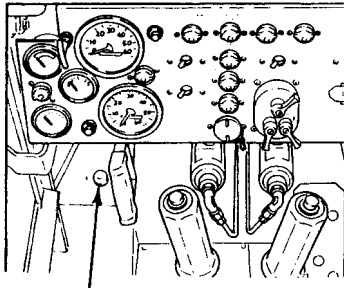

**HEADLIGHT BEAM
SELECTOR SWITCH
M548A1**

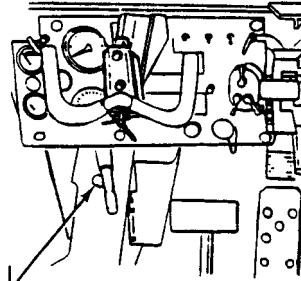

**HEADLIGHT BEAM
SELECTOR SWITCH
M548A3**

5. Release LIGHTS UNLOCK switch.
6. Move DRIVING LIGHTS switch to OFF.

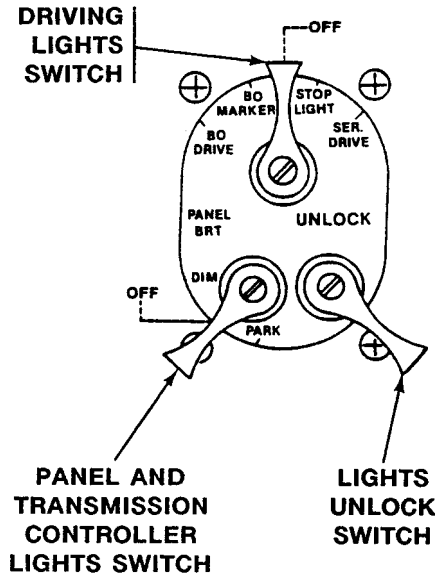

OPERATE BLACKOUT MARKER

1. Move DRIVING LIGHTS switch to BO MARKER.
2. Move PANEL AND TRANSMISSION CONTROLLER LIGHTS switch to OFF.
3. Move DRIVING LIGHTS switch to OFF.

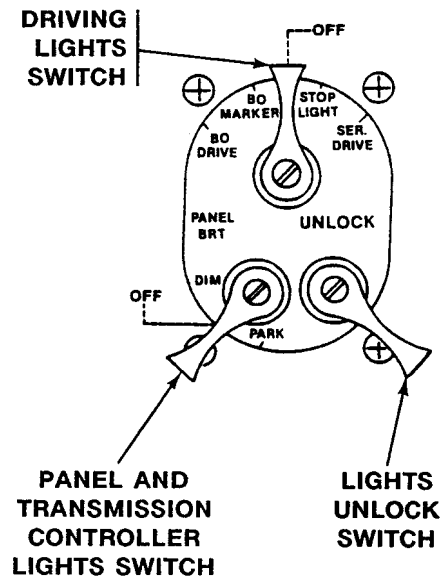

OPERATE BLACKOUT MARKER AND BLACKOUT DRIVING LIGHTS

1. Move LIGHTS UNLOCK switch to UNLOCK, and hold.
2. Move PANEL AND TRANSMISSION CONTROLLER LIGHTS switch to OFF.
3. Move DRIVING LIGHTS switch to BO DRIVE.
4. Release LIGHTS UNLOCK switch.
5. Move IR-BO SELECT switch to BO.
6. Move DRIVING LIGHTS switch to OFF.

BLACKOUT MARKER LIGHTS

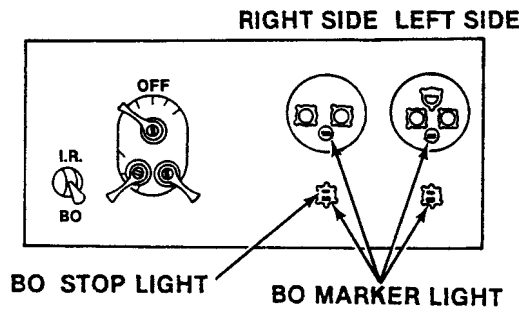

BLACKOUT DRIVING LIGHTS

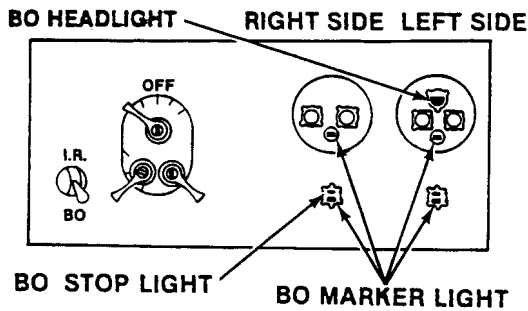

OPERATE STOP LIGHT

1. Move LIGHTS UNLOCK switch to UNLOCK, and hold.
2. Move PANEL AND TRANSMISSION CONTROLLER LIGHTS switch to OFF.
3. Move DRIVING LIGHTS switch to STOP LIGHT.
4. Release LIGHTS UNLOCK switch.
5. Press brake pedal.
6. Release brake pedal.
7. Move DRIVING LIGHTS switch to OFF.

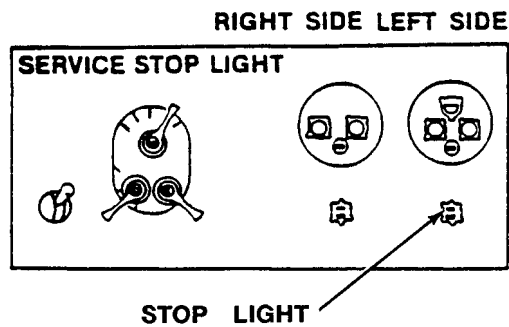

OPERATE INFRARED HEADLIGHTS

1. Move LIGHTS UNLOCK switch to UNLOCK, and hold.
2. Move PANEL AND TRANSMISSION CONTROLLER LIGHTS switch to OFF.
3. Move DRIVING LIGHTS switch to BO DRIVE.
4. Release LIGHTS UNLOCK switch.
5. Move IR-BO SELECT switch to IR.
6. Press HEADLIGHT BEAM SELECTOR switch for HIGH or LOW beam.
7. Move DRIVING LIGHTS switch to OFF.

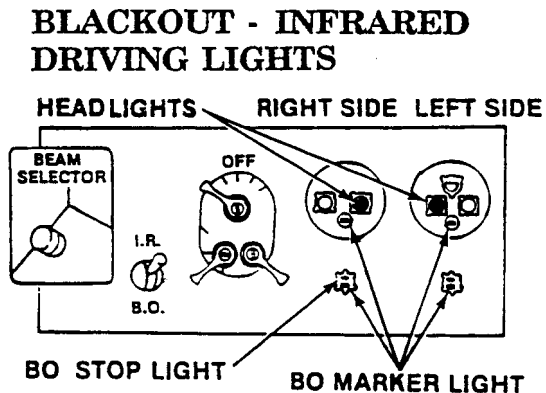

OPERATE PANEL AND TRANSMISSION CONTROLLER LIGHTS

NOTE

PANEL AND TRANSMISSION CONTROLLER LIGHTS will operate only when DRIVING LIGHTS switch is in any position EXCEPT OFF.

1. Move LIGHTS UNLOCK switch to UNLOCK, and hold.
2. Move DRIVING LIGHTS switch to any position EXCEPT OFF.
3. Move PANEL AND TRANSMISSION CONTROLLER LIGHTS switch to DIM or to PANEL BRT.
4. Release LIGHTS UNLOCK switch.
5. Move PANEL AND TRANSMISSION CONTROLLER LIGHTS switch to OFF.
6. Move DRIVING LIGHTS switch to OFF.

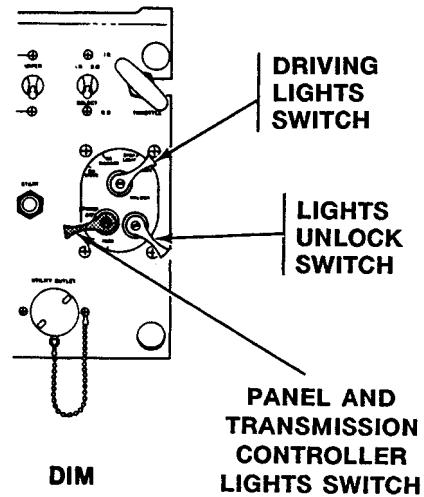

M548A3 SHOWN

END OF TASK

OPERATE FIXED FIRE EXTINGUISHER SYSTEM

0033 00

THIS WORK PACKAGE COVERS:

- Operate Fixed Fire Extinguisher (Outside) (page 0033 00-1).
 - Operate Fixed Fire Extinguisher (Inside) (page 0033 00-3).
-

INITIAL SETUP:

Maintenance Level

Operator

Equipment Condition

Fire extinguisher installed and seal unbroken

Personnel Required

Driver or soldier

OPERATE FIXED FIRE EXTINGUISHER (OUTSIDE)

WARNING

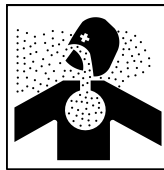

If CO2 is discharged into engine compartment while engine is running, engine exhaust may be poisonous. Poisonous gas can injure you. Stop engine before you discharge CO2. If CO2 is discharged while engine is running, do not breathe engine exhaust.

WARNING



Engine fan can blow away CO2 before fire is extinguished. Personnel can get burned. Equipment can get damaged. Stop engine before you operate fire extinguisher.

NOTE

Unit maintenance should be notified after fixed fire extinguisher is discharged.

1. STOP ENGINE (WP 0023 00) (WP 0024 00).

2. Pull knob control or turn handle to activate outside fire extinguisher. Pull knob or turn handle hard to break lead wire seal.

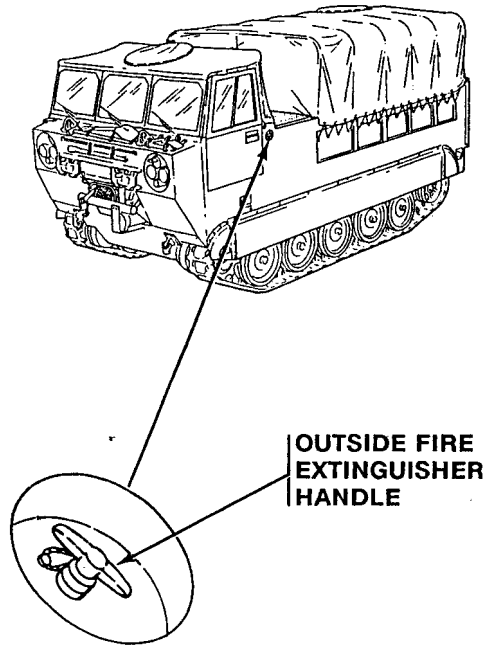

OPERATE FIXED FIRE EXTINGUISHER (INSIDE)

1. STOP ENGINE (WP 0023 00) (WP 0024 00).

NOTE

Fixed fire extinguisher (inside) release is not the same in all carriers. If your carrier has a release handle, go to Step 2. If your carrier has a release knob, go to Step 3.

2. Remove safety pin and rotate inside fire extinguisher handle upward to activate fire extinguisher.
3. Turn fixed fire extinguisher knob to the left to activate fire extinguisher.

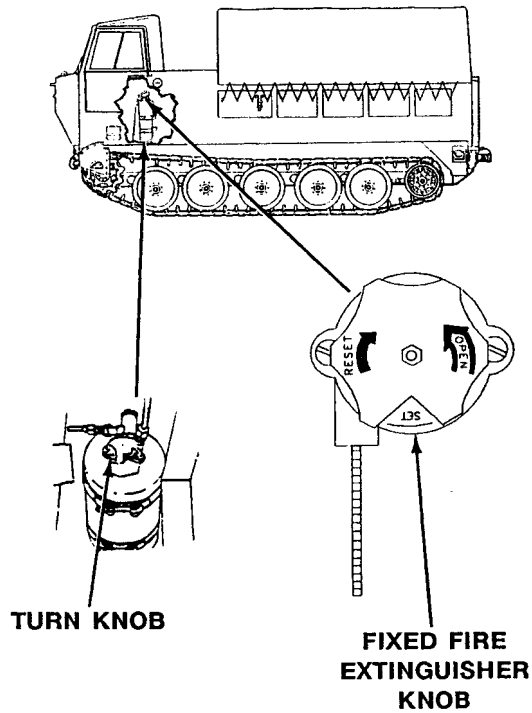

END OF TASK

OPERATE PORTABLE FIRE EXTINGUISHER

0034 00

THIS WORK PACKAGE COVERS:

Operation (page 0034 00-1).

INITIAL SETUP:

Maintenance Level

Operator

Equipment Condition

Fire extinguisher seal unbroken

Personnel Required

Driver or soldier

OPERATION

1. Open two clamps and remove portable fire extinguisher from stowed position in personnel compartment.
2. Remove safety pin from handle.
3. Point nozzle at base of the flames and squeeze the trigger to spray CO₂ (carbon dioxide) on the fire.

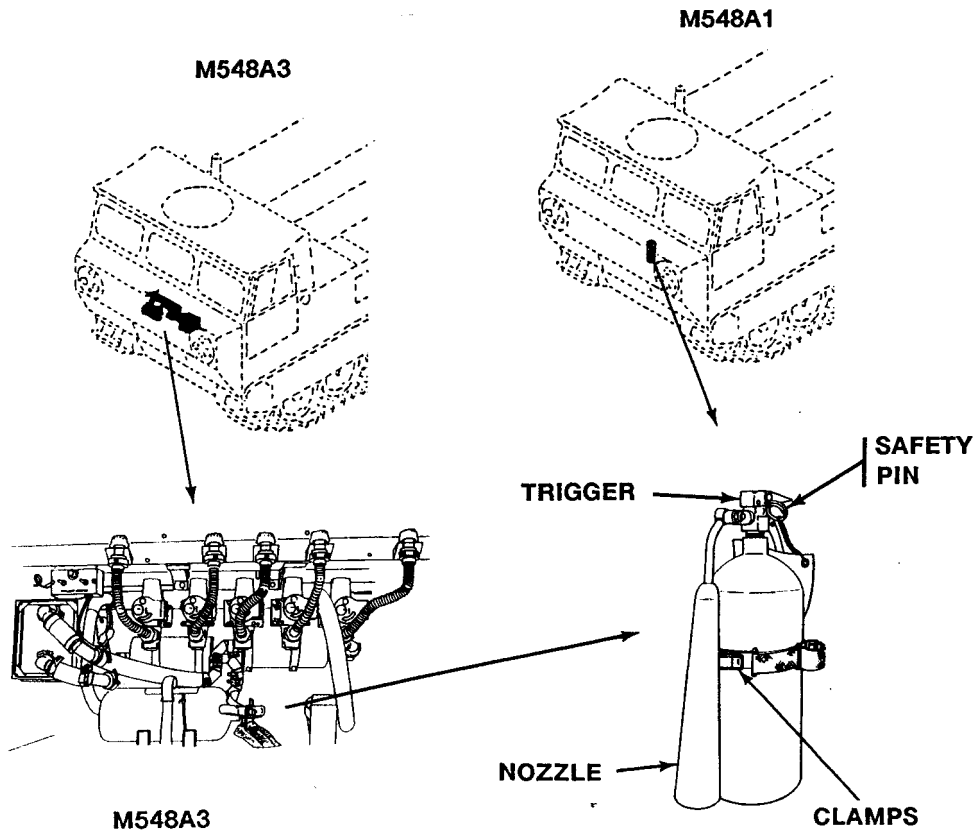

END OF TASK

MACHINE GUN MOUNTING KITS

0035 00

THIS WORK PACKAGE COVERS:

- M66 Mount Controls (page 0035 00-1).
- M49A1 Mount Controls (page 0035 00-2).
- 7.62 MM Machine Gun Mount M60 (page 0035 00-4).

INITIAL SETUP:

Maintenance Level

Operator

Equipment Condition

Engine stopped (WP 0023 00), (WP 0024 00)

Personnel Required

Soldier

References

- TM 9-1005-213-10
- TM 9-1005-224-10

M66 MOUNT CONTROLS

NOTE

The M66 mount includes an adapter so you can mount a caliber.50 machine gun. The adapter is stowed under a circular protective cap to the left of the pintle clamping screw.

1. To remove the machine gun from either mount, remove both cradle pins and lift out the machine gun.
2. Unlock the brake lever to traverse the mount.
3. Lock the brake lever to hold the mount in place.

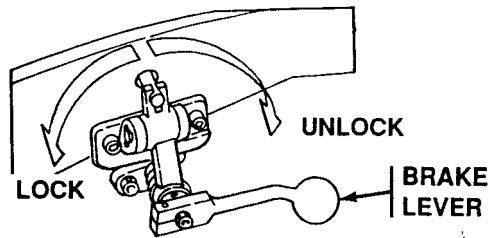

4. Push the pintle traverse lock down to traverse the pintle.
5. Pull the pintle traverse lock up to lock the pintle in place.

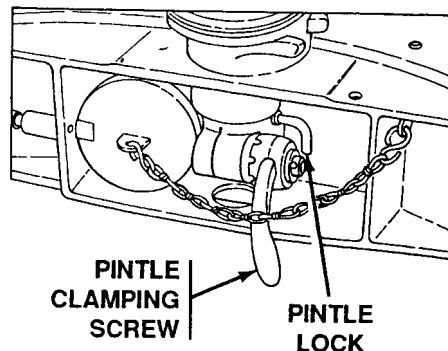

INSTALLATION

1. Turn the pintle lock up, lower the pintle into the mount and turn the pintle lock down.

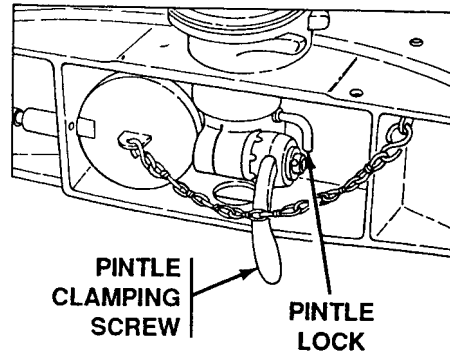
**REMOVAL**

1. Pull the pintle traverse lock down to loosen pintle, turn the pintle lock up and lift out the pintle.

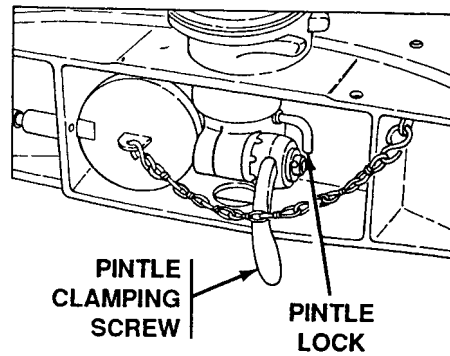
**M49A1 MOUNT CONTROLS**

1. Pull the brake lever handle back and up to traverse the mount. Make sure the detent plungers hold the handle up.
2. Push the brake lever handle down and forward to lock the mount in place.
3. Loosen the pintle clamping screw to traverse the pintle.

4. Tighten the pintle clamping screw to lock the pintle in place.

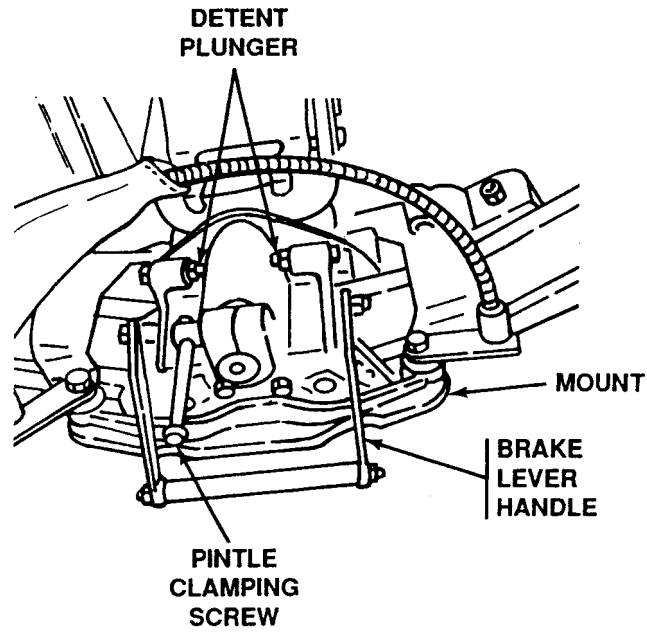

INSTALLATION

1. To install the pintle, lower the pintle into the mount and tighten the pintle clamping screw.

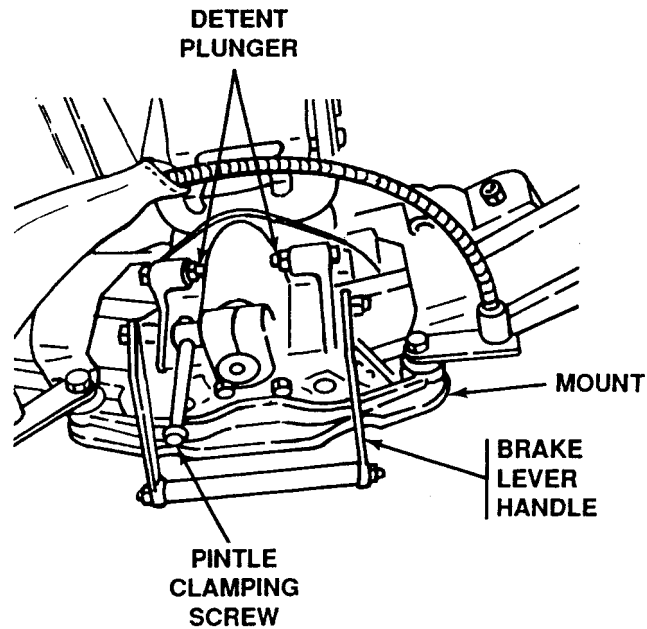

REMOVAL

1. To remove the pintle, loosen the pintle clamping screw enough so you can lift out the pintle.

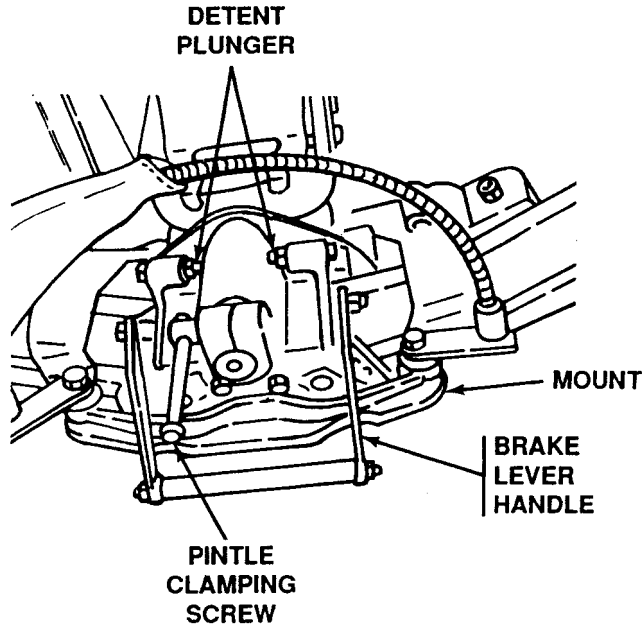

7.62 MM MACHINE GUN MOUNT M60

INSTALLATION

1. Lock the mount and pintle in place and put in the travel lock pin.
2. Catch the front mounting pin (in the machine gun forearm assembly) in the mounting lug on the platform.
3. Catch the rear mounting pin (between the forearm assembly and the trigger housing) in the platform latch.

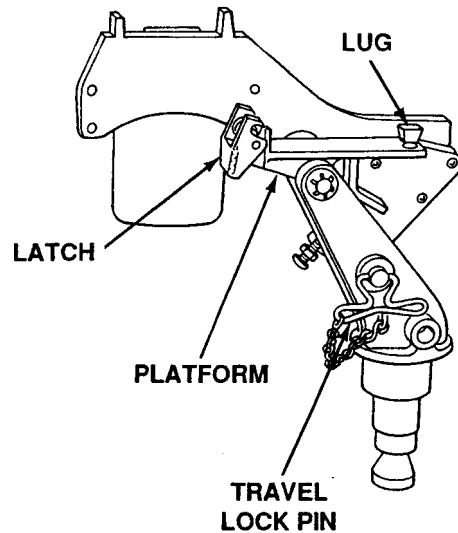

REMOVAL

1. To remove the machine gun, release the platform latch and lift out the machine gun.

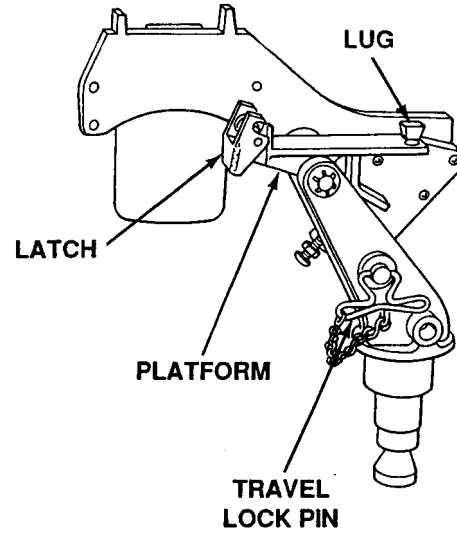
**END OF TASK**

REMOVE/INSTALL POWER PLANT REAR ACCESS COVERS/DOOR AND PANEL

0036 00

THIS WORK PACKAGE COVERS:

- Remove Right Access Cover (page 0036 00-1).
- Install Right Access Cover (page 0036 00-2).
- Remove Upper Rear Access Door (M548A1) (page 0036 00-2).
- Remove Lower Rear Access Cover (M548A1) (page 0036 00-3).
- Install Lower Rear Access Cover (M548A1) (page 0036 00-3).
- Install Upper Rear Access Door (M548A1) (page 0036 00-4).
- Remove Rear Access Panel (M548A3) (page 0036 00-4).
- Install Rear Access Panel (M548A3) (page 0036 00-5).

INITIAL SETUP:

Maintenance Level

Operator

Personnel Required

Driver

Tools and Special Tools

- Socket Wrench Handle (WP 0082 00, Item 27)
- Screwdriver (WP 0082 00, Item 34)
- Socket Wrench, 9/16 inch (WP 0082 00, Item 38)

Equipment Condition

- Engine stopped (WP 0023 00), (WP 0024 00)
- Carrier blocked (WP 0038 00)
- Plywood protector removed (if installed) (WP 0078 00)

REMOVE RIGHT ACCESS COVER

1. Loosen six fasteners and remove access cover from right rear power plant compartment bulkhead. Use screwdriver.

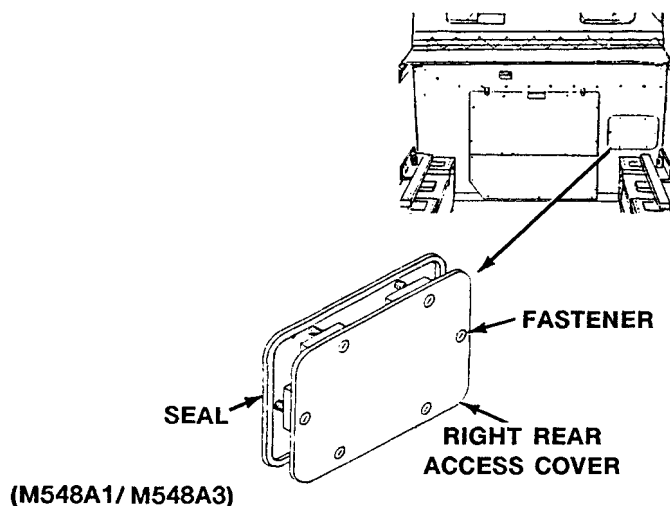

REMOVE/INSTALL POWER PLANT REAR ACCESS COVERS/DOOR AND PANEL —
Continued

0036 00

INSTALL RIGHT ACCESS COVER

1. Inspect seal. Notify unit maintenance if damaged.
2. Install access cover on rear power plant compartment bulkhead. Secure with six fasteners. Use screwdriver.
3. Install plywood protector if removed (WP 0078 00).

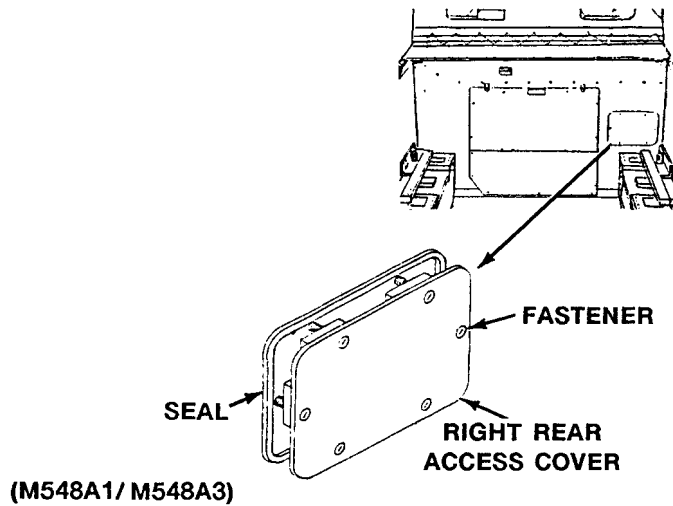

REMOVE UPPER REAR ACCESS DOOR (M548A1)

1. Remove four screws and washers from bulkhead. Swing door up to open position. Use socket and socket handle.
2. Secure door in open position with strap and hook.

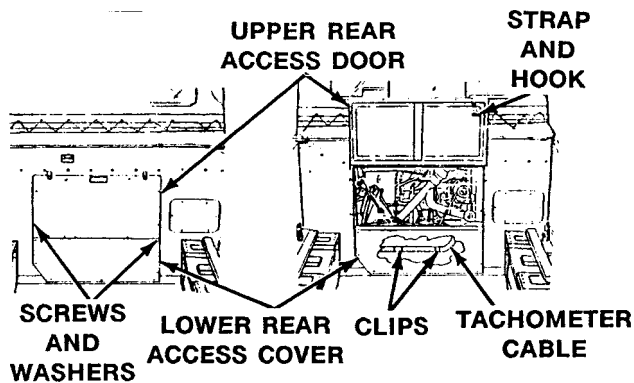

REMOVE/INSTALL POWER PLANT REAR ACCESS COVERS/DOOR AND PANEL —
Continued

0036 00

REMOVE LOWER REAR ACCESS COVER (M548A1)**NOTE**

Upper rear door must be opened before lower rear cover is removed.

1. Open upper rear access door.
2. Remove cargo compartment floor plate (WP 0007 00).
3. Remove tachometer cable from two clips on inside of lower cover.
4. Remove six screws and washers. Use socket and socket handle.
5. Remove lower rear power plant compartment access cover from bulkhead.

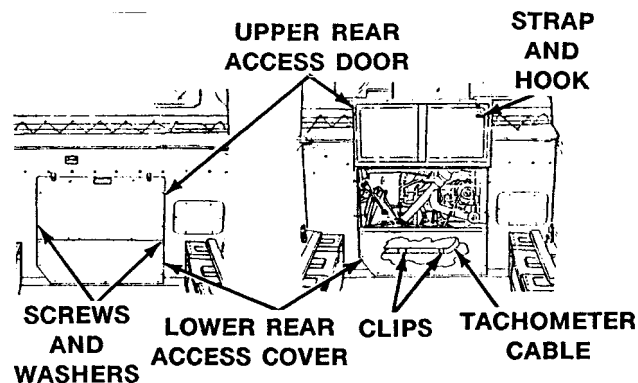
**INSTALL LOWER REAR ACCESS COVER (M548A1)**

1. Install lower rear power plant compartment access cover on bulkhead with six screws and washers. Use socket and socket handle.
2. Install tachometer cable on inside of lower cover with two clips.
3. Install cargo compartment floor plate (WP 0007 00).
4. Close upper rear access door.

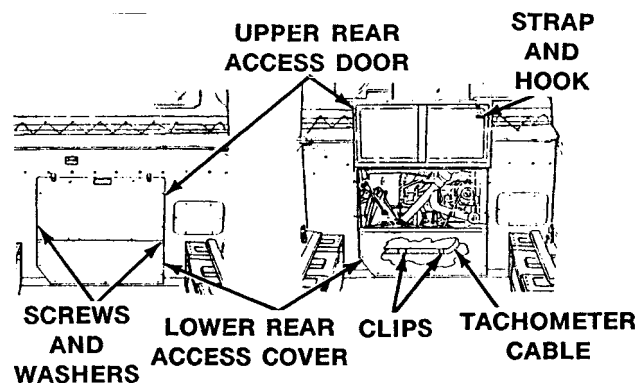

INSTALL UPPER REAR ACCESS DOOR (M548A1)

NOTE

Lower rear cover must be installed before upper rear door is closed.

1. Release strap and hook. Swing door down and closed.
2. Secure door to bulkhead with four screws and washers. Use socket and socket handle.
3. Install plywood protector if removed (WP 0078 00).

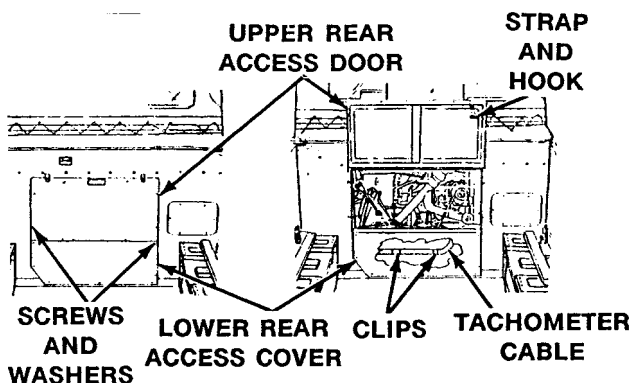

REMOVE REAR ACCESS PANEL (M548A3)

NOTE

Remove cargo compartment floor plate if required (WP 0007 00).

1. Remove two screws and washers from top of rear access panel. Use socket and socket handle.
2. Remove six screws and washers from bottom and sides of rear access panel. Use socket and socket handle.
3. Remove rear access panel from rear power plant compartment bulkhead.

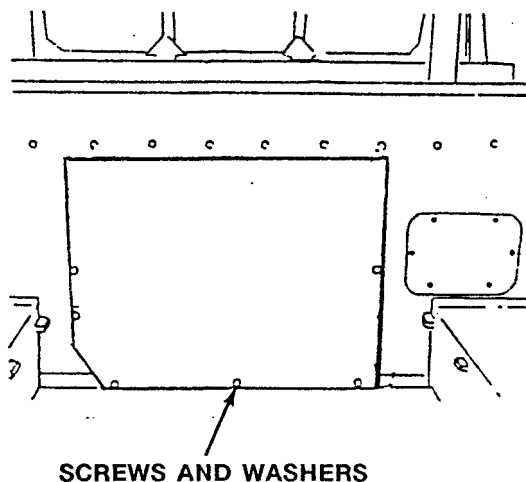

REMOVE/INSTALL POWER PLANT REAR ACCESS COVERS/DOOR AND PANEL —
Continued

0036 00

INSTALL REAR ACCESS PANEL (M548A3)

1. Install rear access panel on rear power plant compartment bulkhead.
2. Install six screws and washers on bottom and sides of rear access panel. Use socket and socket handle.
3. Install two screws and washers on top of rear access panel. Use socket and socket handle.

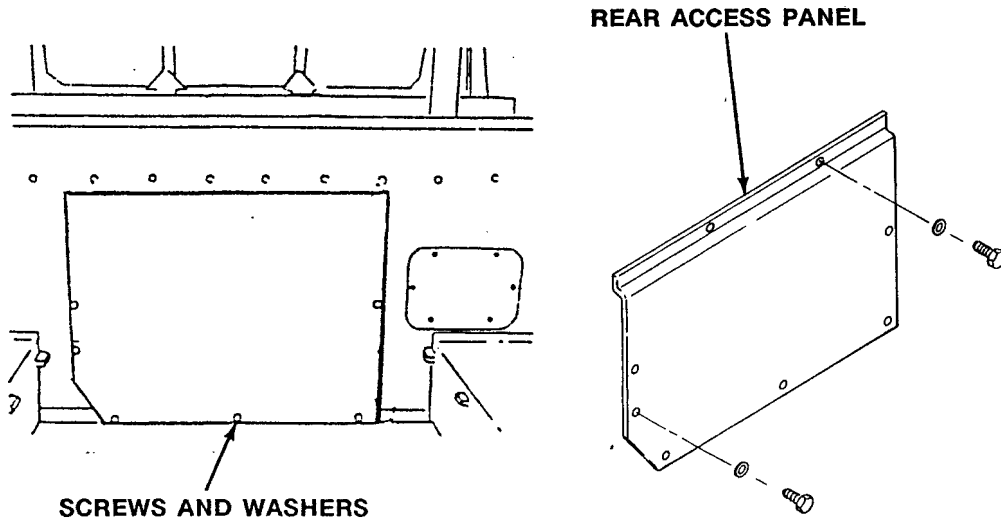
**NOTE**

Install cargo compartment floor plate if removed (WP 0007 00).

4. Install plywood protector if removed (WP 0078 00).

END OF TASK

RAISE/LOWER COMPARTMENT ACCESS DOOR (M548A3)

0037 00**THIS WORK PACKAGE COVERS:**

Raise (page 0037 00-1).
Lower (page 0037 00-1).

INITIAL SETUP:Maintenance Level

Operator

Equipment Condition

Engine stopped (WP 0024 00)
Carrier blocked (WP 0038 00)

Personnel Required

Soldier

RAISE

1. Loosen two tee bolts, securing latch to latch retainer.
2. Turn two latches sideways from latch retainers. Raise door.

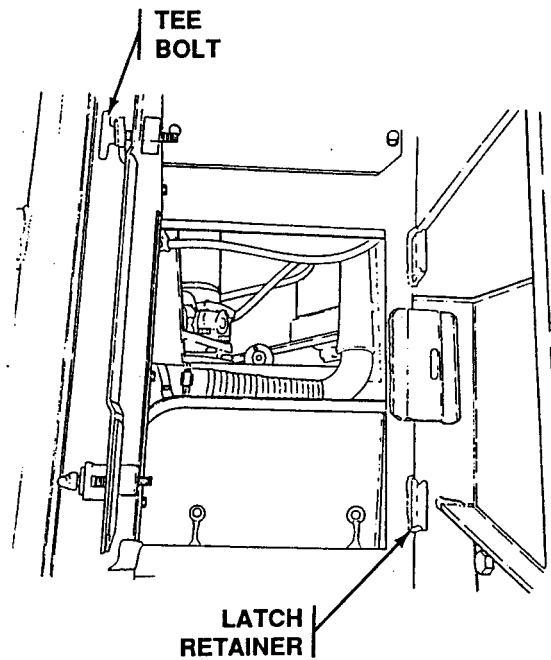
**LOWER**

1. Lower door. Turn two latches under latch retainers.
2. Tighten two tee bolts.

END OF TASK

BLOCK/UNBLOCK CARRIER TRACKS

0038 00

THIS WORK PACKAGE COVERS:

Block (page 0038 00-1).
 Unblock (page 0038 00-1).

INITIAL SETUP:

Maintenance Level

Operator

Personnel Required

Soldier

Materials/Parts

Wood block

Equipment Condition

Carrier stopped

BLOCK CARRIER TRACKS

1. Place wood block or other suitable object between track guides and two sets of road wheels. Make sure block extends full width of both road wheels.

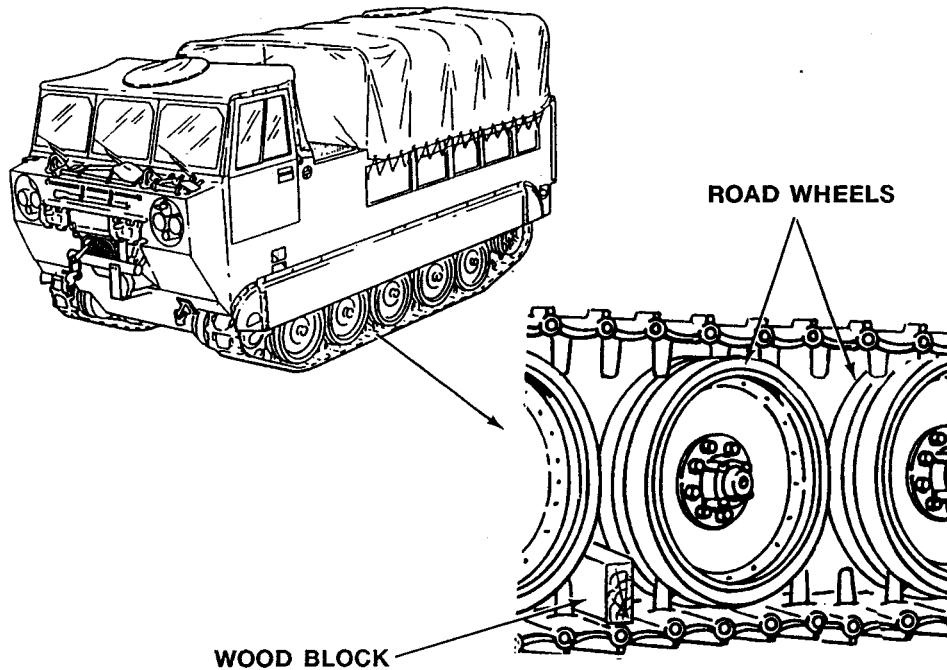

UNBLOCK CARRIER TRACKS

1. Remove wood block or other object from track.

END OF TASK

OPERATE CARRIER IN EXTREME COLD: BELOW -25°F (-31°C)

0039 00

THIS WORK PACKAGE COVERS:

- Do's (page 0039 00-2).
 - Don'ts (page 0039 00-3).
 - Start Engine in Extreme Cold (page 0039 00-3).
 - Stop Engine in Extreme Cold (page 0039 00-3).
-

INITIAL SETUP:

Maintenance Level

Operator

Personnel Required

Driver

References

- FM 9-207
- TC 21-306
- FM 31-70
- FM 31-71
- FM 3-97.6

Equipment Condition

Engine coolant heater kit installed

DO'S

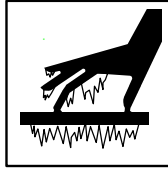
WARNING

Touching metal surfaces of carrier with bare hands may cause injury to personnel. Wear gloves.

CAUTION

Even with antifreeze in it, coolant can freeze. So can batteries. Ordinary oil can get so thick it won't pour, and grease gets as stiff as cold butter. Bare skin can stick to cold metal so tight that you tear skin getting free. Rubber gets hard, and cracks or breaks easily.

CAUTION

You must follow approved methods and precautions for extreme cold operations. FM 9-207 is required reading. It contains information and instructions necessary to operate this carrier in extreme cold (below -25° F (-32° C)).

NOTE

Make sure your carrier has been prepared as described in FM 9-207. You should also become familiar with FM 31-70, FM 31-71, and FM 3-97.6. They contain important information on operation in extreme cold.

In addition to using special fuel, lubricants, and coolant in extreme cold, the carrier should be equipped with an engine coolant heater (WP 0040 00 or WP 0041 00). If you must operate in extreme cold without the coolant heater, you must drain the coolant and remove the batteries to a warm place every time the carrier is shut down. The engine must be preheated before replacing the coolant and engine start up. If you don't have the engine air intake and exhaust covers, use tarpaulins to cover grilles (WP 0026 00 or WP 0027 00).

1. Be alert at all times for the effects of cold on the carrier.
2. Keep an eye on your engine instruments all the time. If you get an unusual reading, stop and check it out right away.
3. Install air inlet and exhaust grille covers and adjust for conditions.
4. Start engine coolant heater as soon as you stop for more than a few hours.
5. Read TC 21-306 to learn about the methods and special hazards of driving on snow, ice, and unusual terrain.
6. Drive carrier slowly in 1 Range for about 100 yards (91 m), before you move out, to warm up the lubricant in the drive train and suspension.
7. Park in shelter whenever you can. If there's no shelter, park so the carrier doesn't face the wind.
8. If you can't park in shelter, put a footing of planks or brush under the tracks so they won't get frozen in.
9. Clean snow, ice, or mud off your carrier as soon as you can.
10. Drain fuel filters and air separator tank, and fill the fuel tanks as soon as you can. Water forms in an empty tank when it cools down. Water anywhere in the fuel system can freeze and block the system.
11. Keep the carrier covered as much as you can. If you can't use the cab and cargo covers, use tarpaulins or anything available to protect the carrier.

DON'TS

1. Park where tracks could be frozen into mud or snow.
2. Let the ends of tarpaulins touch the ground. They could freeze in place.
3. Shut off the engine until engine coolant temperature is at or below 185°F (85°C).

START ENGINE IN EXTREME COLD

1. If your carrier has the engine coolant heater kit and you used the kit (WP 0040 00 or WP 0041 00) while the carrier was parked, use normal cold weather starting procedures (WP 0013 00 or WP 0014 00).
2. Turn off the coolant heater and close the coolant heater shutoff valves (WP 0040 00 or WP 0041 00) before starting the engine.
3. Complete the During Preventive Maintenance Checks and Services (WP 0057 00).
4. If your carrier doesn't have the coolant heater kit, or the kit stopped running and your carrier is cold, get unit maintenance to help you get started.

STOP ENGINE IN EXTREME COLD**CAUTION**

Make sure the engine coolant temperature is 185°F (85°C) or lower before shutting down the engine.

NOTE

Stopping the engine in cold weather is the same as in any other weather conditions (WP 0023 00 or WP 0024 00).

If your compartment heater has been running, wait for the heater to complete its cool down cycle and stop itself after you turn it off. The light will go out when the heater blower stops.

1. Stop engine (WP 0023 00 or WP 0024 00).

END OF TASK

OPERATE ENGINE COOLANT HEATER KIT (M548A1)

0040 00

THIS WORK PACKAGE COVERS:

Operation (page 0040 00-1).

INITIAL SETUP:

Maintenance Level

Operator

Equipment Condition

MASTER SWITCH ON

Personnel Required

Driver

OPERATION

NOTE

The engine coolant heater is a kit installed to prepare the carrier for extreme cold. The kit heats coolant, and circulates the heater coolant through the engine and a heat exchanger plate in the battery compartment. The kit is designed to operate safely while left alone for up to 12 hours. The engine coolant heater controls are on a control box mounted below the middle windshield. Two manual shutoff valves in the power plant compartment let you stop the flow of coolant through the engine coolant heater when it's not running. Here's how to turn it on:

1. Make sure MASTER SWITCH is ON.
2. Turn FUEL PUMP switch OFF.

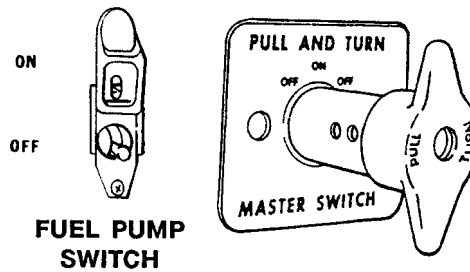

3. Do the During Preventive Maintenance Checks and Services (WP 0057 00).
4. Open both coolant valves by turning valve handles counterclockwise as far as they'll go. The coolant shutoff valve is at the upper right front corner of the engine behind the secondary fuel filter. The coolant diverting valve is on the lower left front corner of the engine.

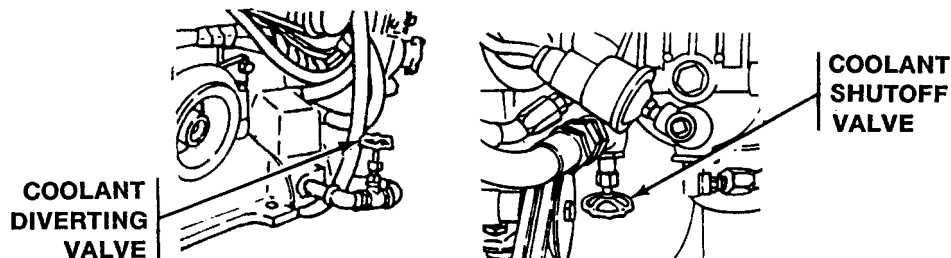

NOTE

The coolant shutoff valve should be opened only during operation of the engine coolant heater.
The coolant diverting valve may be left open at all times.

5. Press the indicator light housing. If the light glows, you know you have power to the heater controls. If the light doesn't glow when you press the housing, notify unit maintenance.

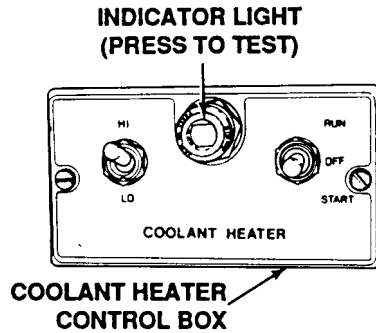
**CAUTION**

Overheating will damage the batteries. Don't use the engine coolant heater if the temperature is above -25°F (-32°C). Make sure both manual shutoff valves are open before you start the heater. If coolant doesn't flow, the heater will be damaged.

6. Hold RUN-OFF-START switch to START until indicator light comes on. Then move switch straight to RUN without stopping in the OFF position.

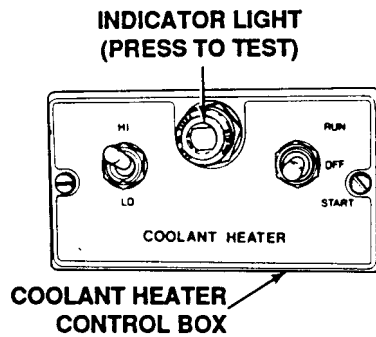

NOTE

When the switch is at **HI**, the heater will automatically transfer to low heat if coolant temperature reaches 190°F (88°C), and will switch back to high heat if coolant temperature drops to 120°F (49°C). If coolant should reach 245°F ±15°F (118°C ±9°C), the heater will stop automatically and must be restarted manually.

7. Select high or low heat with the HI-LO switch. The heater will always start on low heat no matter how the HI-LO switch is set, and will go to high after it starts, if the switch is set at HI.

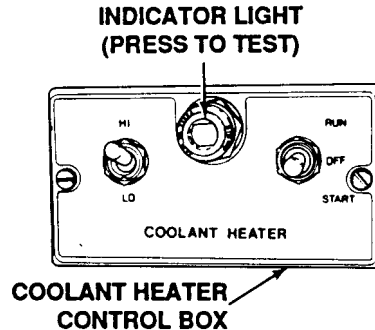

8. If heater doesn't start, try again. If it doesn't start in three tries, notify unit maintenance.

CAUTION

To avoid discharging batteries, do not operate lights, radios, or other electrical equipment for very long while coolant heater is running. Always turn off heater and close coolant shutoff valve before you start engine.

9. If you don't operate carrier after 12 hours of running engine coolant heater, run the engine until batteries are charged. Stop coolant heater while the engine is running. Keep fuel tank full.

NOTE

The heater will stop burning right away, but the combustion air blower will run until the heater is purged of fuel and the burner is cool. The indicator light will stay on until the blower stops. Close the coolant shutoff valve by turning the handle clockwise whenever you stop the heater.

10. To turn heater off, move the RUN-OFF-START switch to OFF.

END OF TASK

OPERATE ENGINE COOLANT HEATER KIT (M548A3)

0041 00

THIS WORK PACKAGE COVERS:

Operation (page 0041 00-1).

INITIAL SETUP:

Maintenance Level

Operator

Equipment Condition

MASTER SWITCH ON

Personnel Required

Driver

OPERATION

NOTE

The engine coolant heater keeps batteries and engine warm for easier starting during extreme cold, -25°F (-32°C) or below. The coolant is heated and circulated through the engine and two heat exchanger plates in battery compartment. The heater is designed to operate safely while left alone for up to 12 hours. The engine coolant heater controls are on a control box mounted below the middle windshield. Two manual shutoff valves in power plant compartment let you stop the flow of coolant through the engine coolant heater when it's not running.

1. Make sure MASTER SWITCH is ON.
2. Turn FUEL PUMP switch OFF.

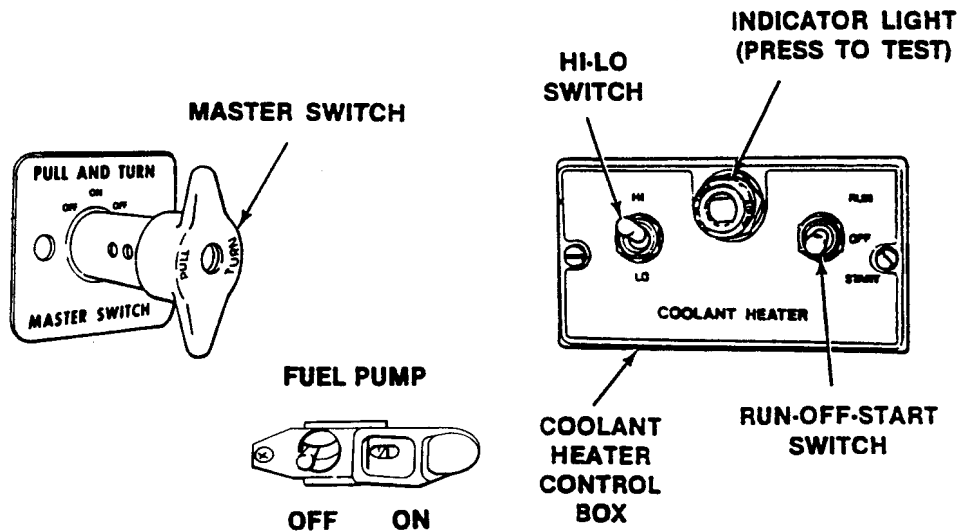

NOTE

The coolant shutoff valve (inlet) should be opened only during operation of the engine coolant heater. The coolant shutoff valve (outlet) may be left open at all times.

- Open both shutoff valves by turning valve handles counterclockwise as far as they'll go. One coolant shutoff valve (inlet) is at the upper right front corner of the engine. Another coolant shutoff valve (outlet) is on the lower left side of the engine next to air cleaner.

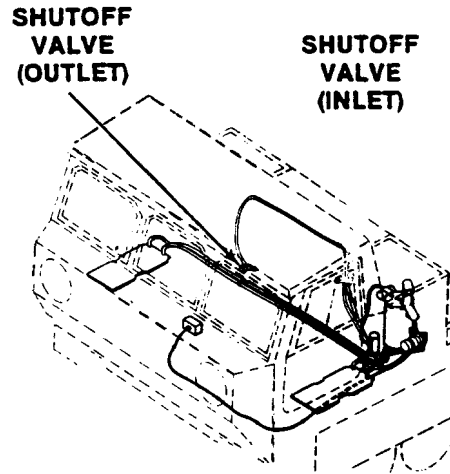

- Press the indicator light housing. If the light glows, you know you have power to the heater controls. If the light doesn't glow when you press the housing, troubleshoot heater (WP 0055 00).

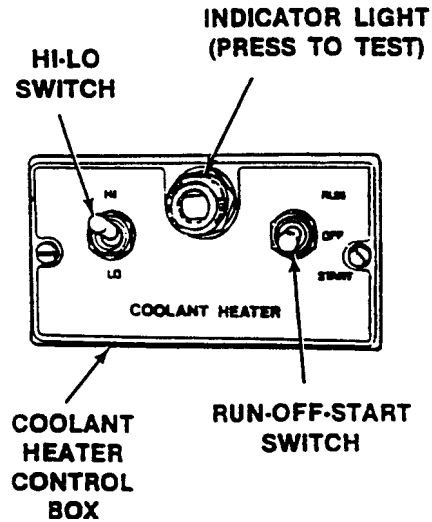

CAUTION

Overheating will damage the batteries. Don't use the engine coolant heater if the temperature is above -25°F (-32°C). Make sure both manual shutoff valves are open before you start the heater. If coolant doesn't flow, the heater will be damaged.

5. Hold RUN-OFF-START switch to START until indicator light comes on. Then move switch straight to RUN without stopping in the OFF position.

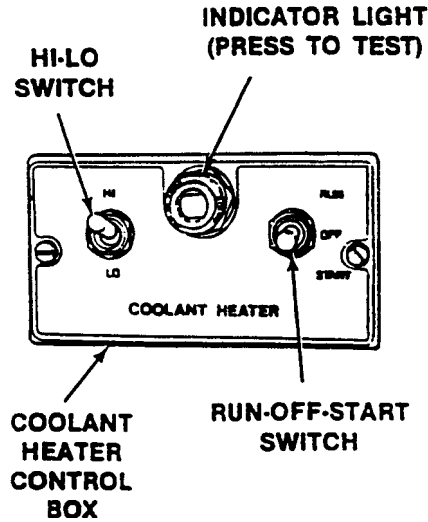
**NOTE**

When the switch is at **HI**, the heater will automatically transfer to low heat if coolant temperature reaches 190°F (88°C), and will switch back to high heat if coolant temperature drops to 120°F (49°C). If coolant should reach $245^{\circ}\text{F} \pm 15^{\circ}\text{F}$ ($118^{\circ}\text{C} \pm 9^{\circ}\text{C}$), the heater will stop automatically and must be restarted manually.

6. Select high or low heat with the hi-lo switch. The heater will always start on low heat no matter how the hi-lo switch is set, and will go to high after it starts if the switch is at HI.
7. If heater doesn't start, try again. If it doesn't start in three tries, troubleshoot it (WP 0055 00).

CAUTION

To avoid discharging batteries, do not operate lights, radios, or other electrical equipment for very long while coolant heater is running. Always turn off heater and close coolant shutoff valve (inlet) before you start engine.

NOTE

The heater will stop burning right away, but the combustion air blower will run until the heater is purged of fuel and the burner is cool. The indicator light will stay on until the blower stops. Close the coolant shutoff valve (inlet) by turning the handle clockwise whenever you stop the heater.

8. If you don't operate carrier after 12 hours of running engine coolant heater, run the engine until batteries are charged. Stop coolant heater while the engine is running. Keep fuel tank full.

9. To turn heater off, move the RUN-OFF-START switch to OFF.

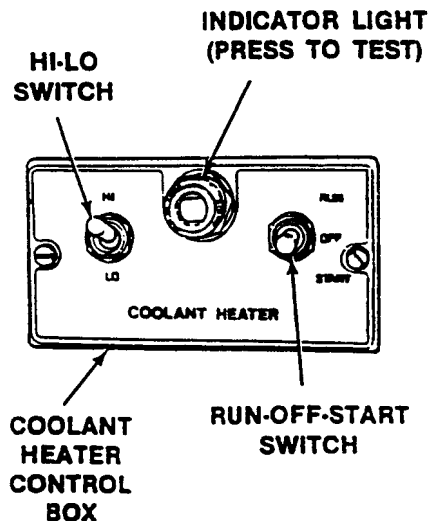

CAUTION

Do not turn master switch OFF until blower stops. Damage to engine coolant heater may result.

10. Turn MASTER SWITCH to OFF.

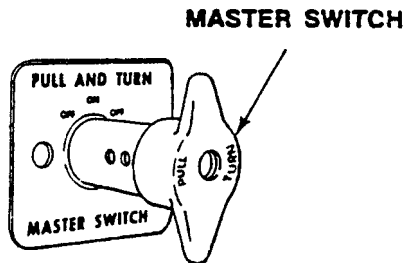

END OF TASK

PERFORM PRE-FORDING OPERATIONS

0042 00

THIS WORK PACKAGE COVERS:

Perform Pre-Fording Operations (page 0042 00-1).

INITIAL SETUP:

Maintenance Level

Operator

Equipment Condition

Engine stopped (WP 0023 00), (WP 0024 00)
Carrier blocked (WP 0038 00)

Tools and Special Tools

Socket Wrench Adapter (WP 0082 00, Item 1)
Socket Wrench Handle (WP 0082 00, Item 27)

Personnel Required

Driver
Crew

PERFORM PRE-FORDING OPERATIONS

WARNING

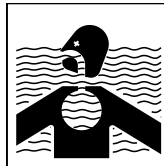

Water will enter carrier during water operation when components are not properly installed. Carrier may sink, Death may result. Make sure all access covers, drain covers and drain plugs are in place, straight and tight. Be sure fuel filler cap is sealed.

WARNING

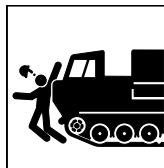

Personnel could be killed or injured if carrier moves with someone under it. Make sure engine is stopped, parking brake is set or steering levers locked, and carrier tracks blocked before crawling under carrier.

NOTE

Before fording carrier, make sure heater access cover, hull access cover, drain covers, or float valves, final drive drain plugs and fuel filler cap are in place and tight. Use socket wrench handle and adapter to check or install final drive drain plugs.

1. Remove lower hull access cover and inspect gasket. If gasket is missing or damaged, notify unit maintenance. Install access cover securely.

2. Make sure tailgate and cab door seals are in good condition. If seals are missing or damaged, notify unit maintenance.
3. Make sure cab doors, tailgate, and cargo compartment door are closed tight and latched securely.

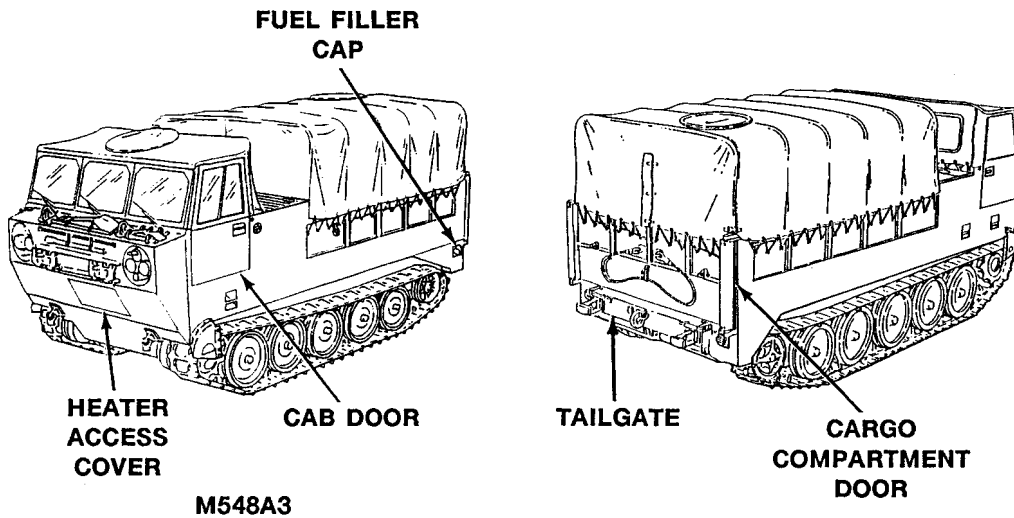
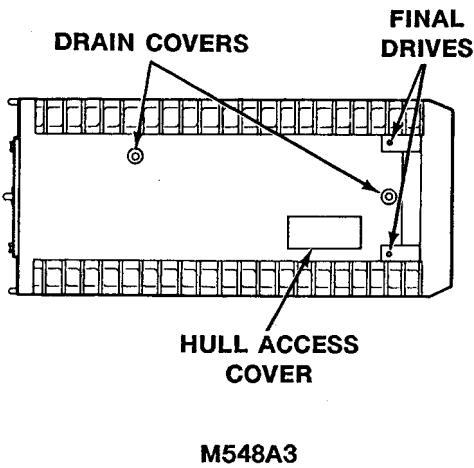
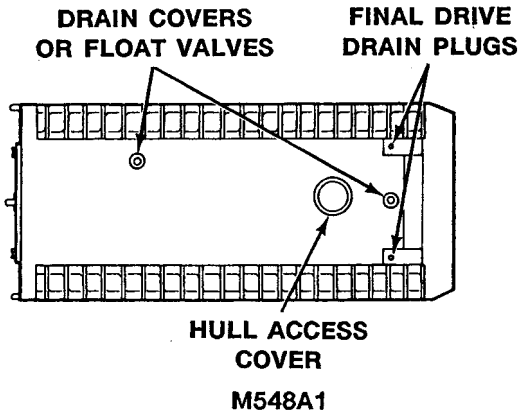

4. Make sure all cargo and basic issue items are secured in place.

NOTE

If there is water in the bilge, you should see it coming out the bilge pump outlet. If you don't see a flow of water, put your hand over outlets and feel for a flow of air.

Only the FWD (forward) bilge light will be illuminated. There is no aft (rear) bilge pump.

- Run bilge pump to make sure it is working. With carrier on level ground, turn the bilge pump switch to ON. The forward bilge pump indicator light should come on.

**BILGE
PUMP OUTLET**

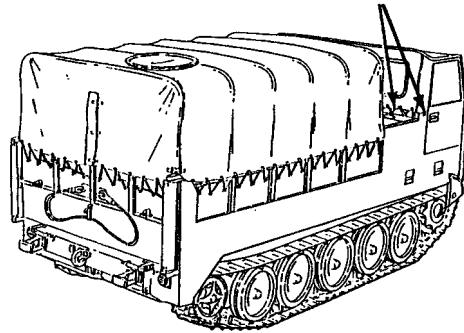

**ON INDICATOR LIGHT
FORWARD BILGE PUMP**

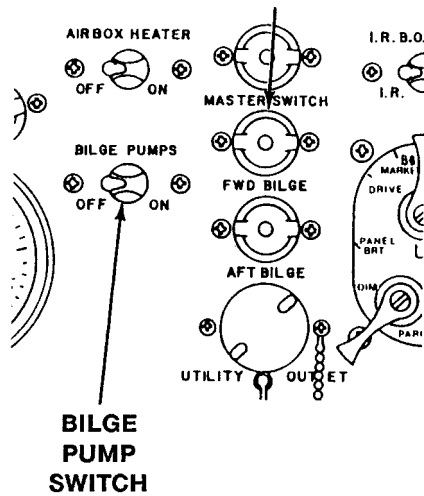

M548A1

**ON INDICATOR LIGHT
FORWARD BILGE PUMP**

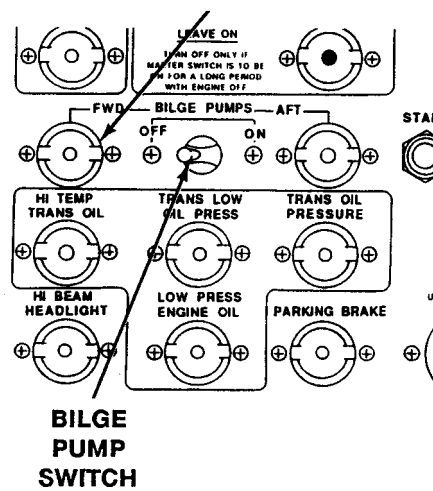

M548A3

END OF TASK

FORD WATER UP TO 40 INCHES DEEP

0043 00

THIS WORK PACKAGE COVERS:

Ford Water Up to 40 Inches Deep (page 0043 00-1).

INITIAL SETUP:

Maintenance Level

Operator

Personnel Required

Driver

Crew

Equipment Condition

Engine stopped (WP 0023 00), (WP 0024 00)

Carrier blocked (WP 0038 00)

FORD WATER UP TO 40 INCHES DEEP

WARNING

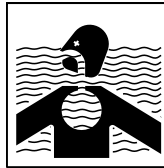

Do not swim carrier. M548A1 and M548A3 carriers can ford water up to 40 inches deep. However, these carriers do not swim. When water depth is unknown or deeper than 40 inches (91 cm), do not attempt to ford stream. Carrier may sink and personnel could drown. See task: (WP 0042 00).

WARNING

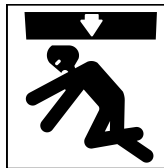

Personnel could be killed or injured if carrier moves with someone under it. Make sure engine is stopped, parking brake set, and carrier tracks blocked before crawling under carrier.

WARNING

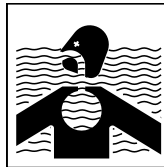

Personnel may drown if the carrier tips over or the water is deeper than 40 inches (91 cm). Make sure everyone riding in the carrier knows how to get out in a hurry in case of an emergency. Do not wear seat belts while in the water.

1. Check bilge pump operation (WP 0073 00).

2. Choose spot to enter and exit water. Look for firm ground without rocks, stumps, or other obstacles. Avoid steep slopes and soft ground.
3. Ensure the maximum speed of the water current allowable at 30 to 40 inches of depth is 2.5 mph (4.0 kilometers, double time or a fast walking speed), 20 to 30 inches of depth is 4 mph (6.5 kilometers, double time or fast walk), at 10 to 20 inches of depth is 6 mph (9.6 kilometers, jog or slow run, below top of roadwheel), at 10 inches or less is 10 mph (16.1 kilometers).
4. Unblock carrier tracks (WP 0038 00).
5. START ENGINE (M548A1) (WP 0013 00) (M548A3) (WP 0014 00).
6. Place BILGE PUMP switch ON.

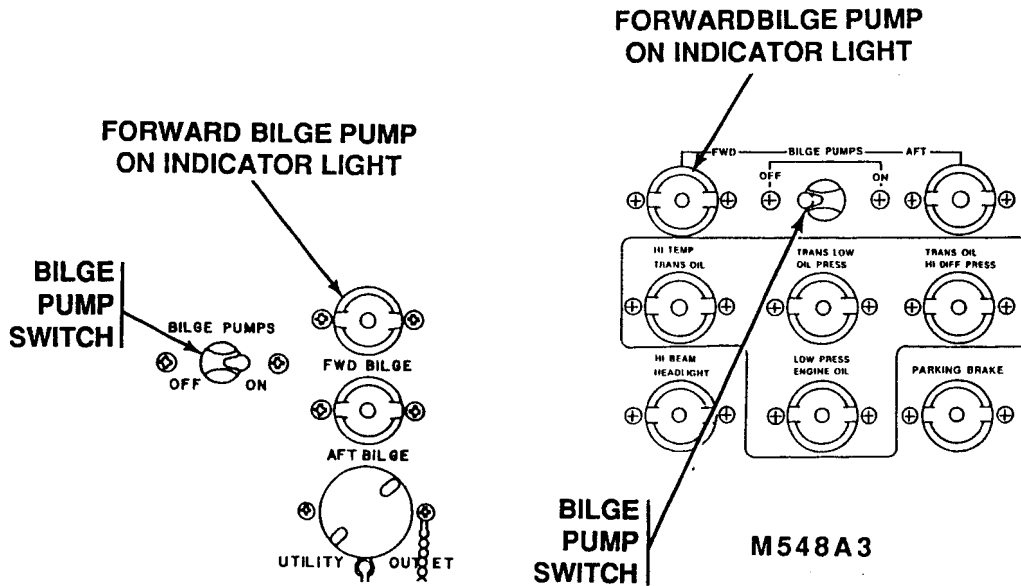

7. Place transmission shift controller in 1-2 range and enter water (WP 0020 00) (WP 0021 00).
8. Proceed slowly. Watch out for obstacles under water.

NOTE

If you ever think carrier is in danger of swamping, head for the nearest shore. You can speed up if that will help, but do it smoothly.

9. Head for the bank as evenly as you can. Maneuver a little if you need to, so both tracks are balanced and grip the ground firmly. Give it enough throttle to climb out straight and smooth.

CAUTION

It may be hard to steer if one track is grounded and the other isn't. Go easy until you're sure both tracks are on solid ground.

10. Exit water. After bilge pump empties, place BILGE PUMP switch to OFF.

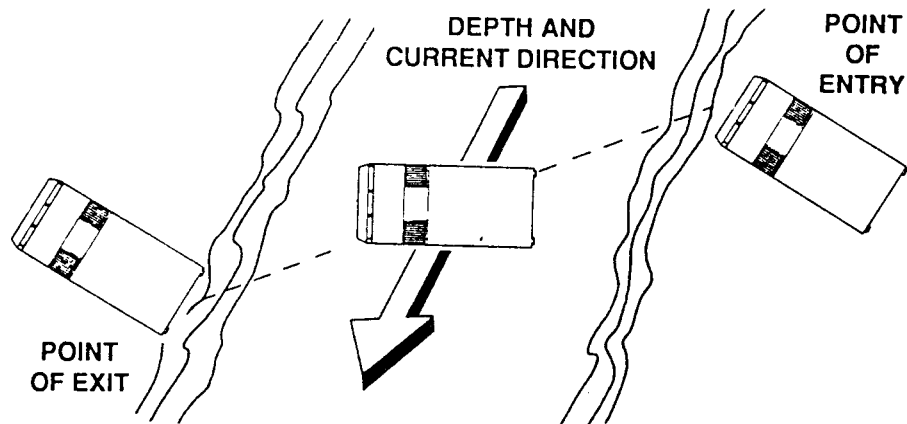

11. Inspect and service carrier as soon as you can after water operations (WP 0044 00).

END OF TASK

PERFORM POST-FORDING OPERATION

0044 00

THIS WORK PACKAGE COVERS:

Operation (page 0044 00-1).

INITIAL SETUP:

Maintenance Level

Operator

References

See your PMCS

Personnel Required

Driver

Crew

Equipment Condition

Carrier forded (WP 0043 00)

PERFORM POST-FORDING OPERATION

1. Drive carrier to firm, level ground (WP 0020 00) (WP 0021 00).
2. Place BILGE PUMP switch OFF when water stops draining from bilge outlet.

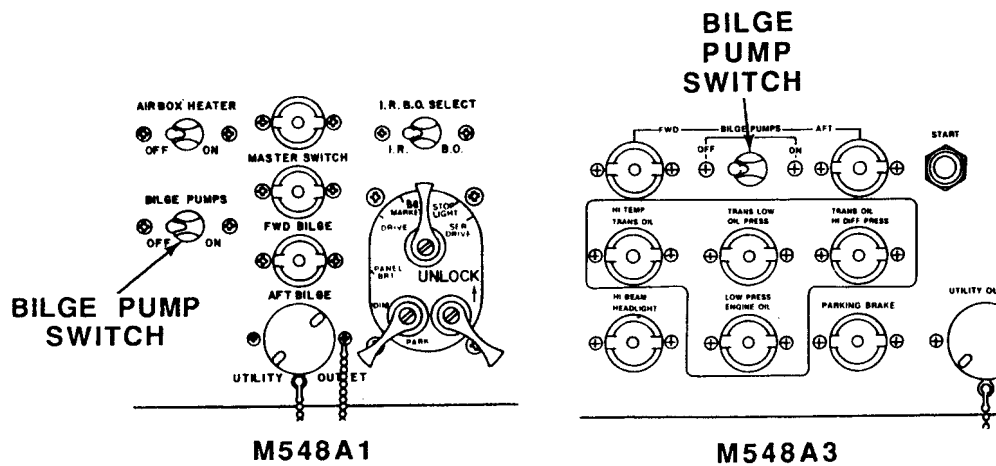

3. STOP ENGINE (WP 0023 00) (WP 0024 00).
4. Check for water in final drive oil. See PMCS (WP 0057 00). If bubbles or white color are seen on dipstick, oil has water in it. Notify unit maintenance.

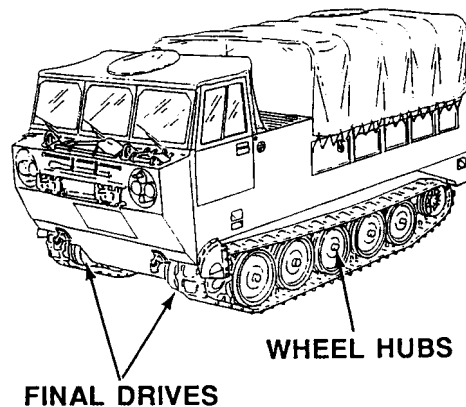

5. Check roadwheel hubs for water. Lubricate carrier chassis. See PMCS (WP 0057 00) as soon as tactical situation permits.
6. Lubricate carrier chassis. See PMCS (WP 0057 00) as soon as tactical situation permits.

CAUTION

Keep bilge clean. Dirt or trash in the bilge can clog the bilge pump.

7. If carrier has been in salt water, flush outside with fresh water. Have unit maintenance remove all drain plugs and flush bilges with fresh water. Keep water away from radios and all electrical wiring. Install drain plugs.

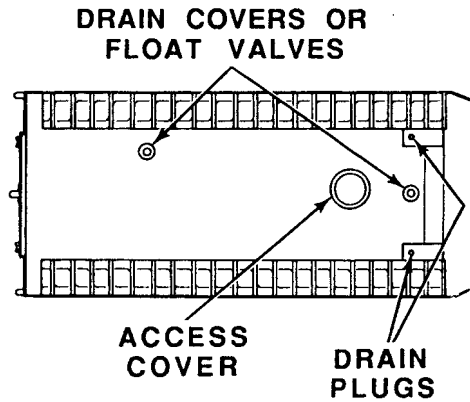

M548A1

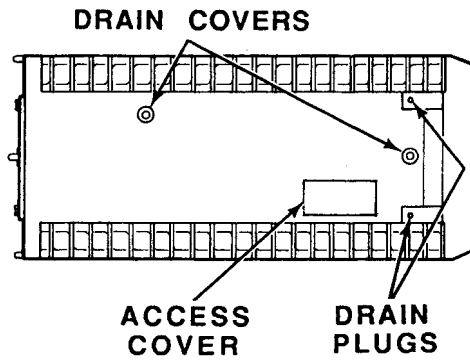

M548A3

END OF TASK

OPERATE CARRIER OVER ROUGH TERRAIN

0045 00

THIS WORK PACKAGE COVERS:

- Drive Carrier Over Trenches (page 0045 00-2).
- Drive Carrier Over Obstacles (page 0045 00-3).
- Drive Carrier On Grades (page 0045 00-3).
- Drive Carrier On Side Slopes (page 0045 00-4).
- Drive Carrier On Snow, Ice, Or Mud (page 0045 00-5).
- Park Carrier On Snow, Ice, Or Mud (page 0045 00-5).

INITIAL SETUP:

Maintenance Level

Operator

Equipment Condition

Engine started (WP 0012 00), (WP 0013 00).

Personnel Required

Driver
Crew

DRIVE CARRIER OVER TRENCHES

WARNING

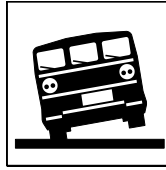

Carrier can roll over and kill or injure personnel. Avoid high speeds and sudden turns when driving on hills or rough terrain. Wear seat belts.

CAUTION

Carrier will get stuck in trenches wider than 5 1/2 feet (1.67 m). Do not cross trenches wider than 5 1/2 feet (1.67 m).

NOTE

The M548A1 has a transmission range selector and the M548A3 has a transmission shift controller. For purposes of this task, the M548A3 transmission shift controller is shown.

1. Move transmission shift controller to 1 or 1-2 range (WP 0004 00).

TRANSMISSION
SHIFT
CONTROLLER

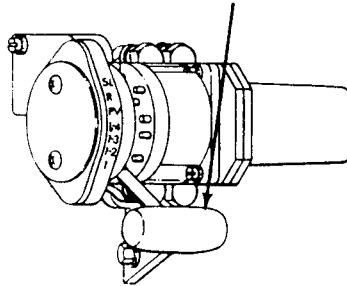

2. Approach trench straight on and drive slowly over trench. Accelerate when track contacts far side of trench.

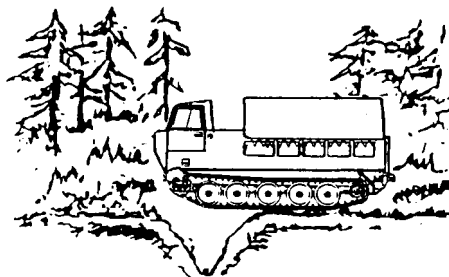

DRIVE CARRIER OVER OBSTACLES**CAUTION**

Obstacles higher than 24 inches (61 cm) can damage carrier. Do not drive over obstacles higher than 24 inches (61 cm).

1. Move transmission shift controller to 1 or 1-2 range (WP 0004 00).

**TRANSMISSION
SHIFT
CONTROLLER**

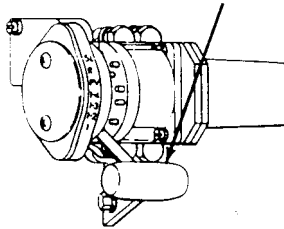

2. Approach obstacle straight on and drive slowly over obstacle.

DRIVE CARRIER ON GRADES

1. Move transmission shift controller to 1-2 range for grades up to 30% and 1 range for grades from 30% to 60%.

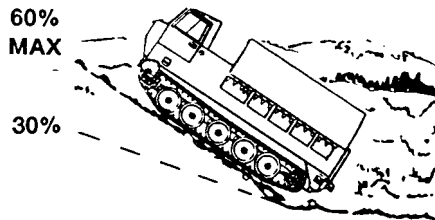

**TRANSMISSION
SHIFT
CONTROLLER**

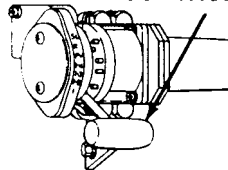

2. Accelerate as carrier climbs a grade. Decelerate when you reach top of grade and during descent.

DRIVE CARRIER ON SIDE SLOPES

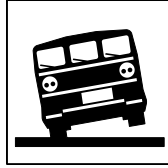
WARNING

Carrier can roll over and kill or injure personnel. Do not drive on side slopes steeper than 30%.

1. Move transmission shift controller to 1 or 1-2 range (WP 0004 00).

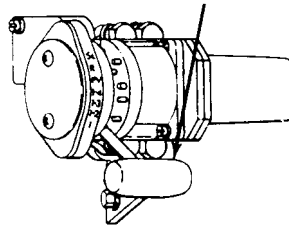
**TRANSMISSION
SHIFT
CONTROLLER****CAUTION**

Sharp turns on snow, ice, or mud can cause carrier to throw a track. Make a series of small wide turns instead of one sharp turn.

2. Steer in a series of small wide turns rather than one sharp turn.

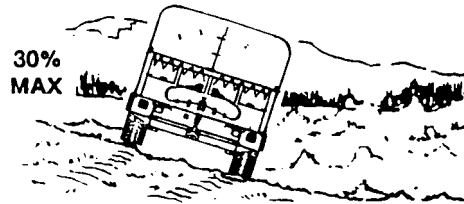

DRIVE CARRIER ON SNOW, ICE, OR MUD**CAUTION**

Sharp turns on snow, ice, or mud can cause carrier to throw a track. Make a series of small wide turns instead of one sharp turn.

NOTE

If you operate often in snow, ice, mud, or heavy brush, have unit maintenance remove the track shrouds.

Do not drive on snow-covered grades unless you have to. If you do, go as straight up and down the slope as you can.

1. Use a low transmission range that moves carrier smoothly without digging in. Drive slowly to avoid skidding.

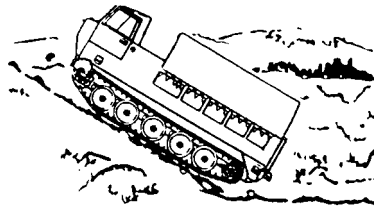

2. Slow carrier smoothly before making a turn.
3. If carrier breaks through crest of deep snow or soft soil, steer carrier straight to get back on crest.

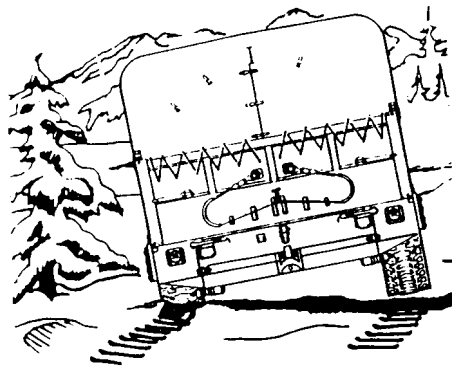
**PARK CARRIER ON SNOW, ICE, OR MUD**

1. If possible, stop carrier on firm surface.
2. When mission is completed, park carrier in a sheltered area with front of carrier faced away from the wind.
3. Clear snow, ice, and mud off road wheels and tracks after parking.
4. If carrier is parked in low area where water may freeze under tracks, put brush or branches under tracks.

END OF TASK

OPERATE CARRIER IN EXTREME HEAT, HUMIDITY, OR SALTY CONDITIONS

0046 00

THIS WORK PACKAGE COVERS:

Operation (page 0046 00-1).

INITIAL SETUP:

Maintenance Level

Operator

References

TB Med 507

Personnel Required

Driver

OPERATE CARRIER IN EXTREME HEAT, HUMIDITY, OR SALTY CONDITIONS

1. Check gauges and warning lights often when driving. If any warning light comes on, stop engine (WP 0023 00 or WP 0024 00). Troubleshoot problem (WP 0055 00).

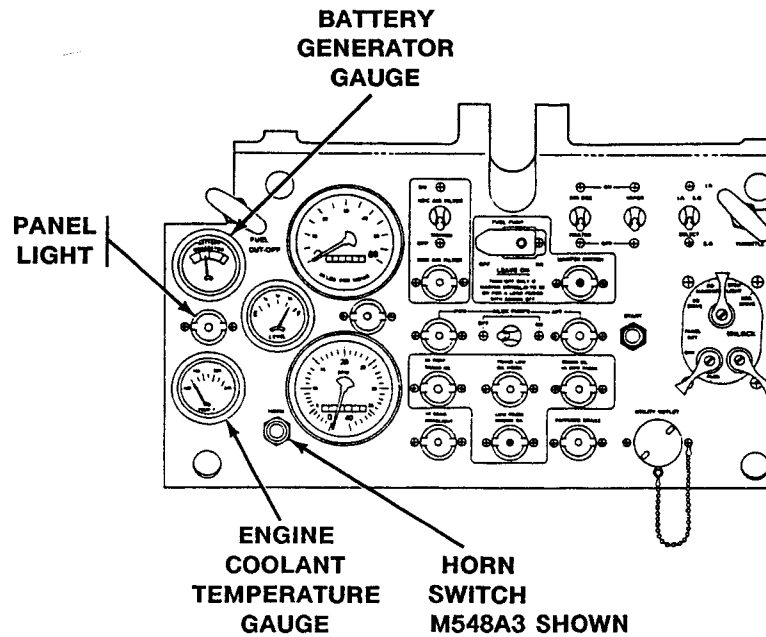

WARNING



Carrier operation during hot weather may result in potential heat stress to crew members. Crew members should limit their exposure based on TB Med 507.

2. Check engine coolant level often (WP 0065 00 or WP 0066 00).

**OPERATE CARRIER IN EXTREME HEAT, HUMIDITY, OR SALTY
CONDITIONS — Continued**

0046 00

3. Check air cleaner indicator often. If at any time only red shows in the window, notify unit maintenance.

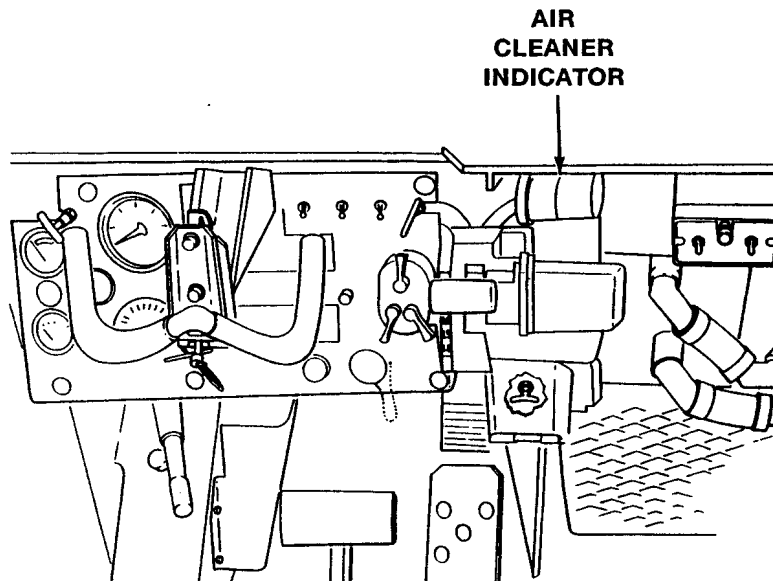

4. Check level of water in batteries (WP 0070 00).
5. Don't drive in any transmission range below 1-3 when you don't have to.
6. Don't let dirt, sand, or bugs build up in the radiator fins. Have unit maintenance clean fins with water pressure.
7. Lubricate frequently (WP 0057 00). Heat, sand, dust, humidity, and salt all have a bad effect on lubricants and moving parts.
8. Stop and fix any problem as soon as it comes up, or as soon as tactical situation allows.
9. Keep carrier clean. Fungus and mildew can grow fast in conditions of high heat and humidity. Look carrier over and clean it often.
10. Keep carrier in shelter or shade as much as possible. Cover carrier with tarpaulins when it is parked. If you cannot cover entire carrier, at least cover intake and exhaust grilles (WP 0026 00 or WP 0027 00).

END OF TASK

BYPASS DEFECTIVE TRANSMISSION CONTROLLER (M548A3)

0047 00

THIS WORK PACKAGE COVERS:

Bypass Defective Transmission Controller (page 0047 00-1).

INITIAL SETUP:

Maintenance Level

Operator

Equipment Condition

Engine started (WP 0014 00)

Personnel Required

Driver

BYPASS DEFECTIVE TRANSMISSION CONTROLLER (M548A3)

NOTE

If carrier does not move in any transmission controller position, controller may be defective. Do Steps 1 - 5 below to bypass defective transmission controller allowing you to drive carrier.

1. Disconnect wiring harness from transmission controller.
2. Open tow start handle cover.

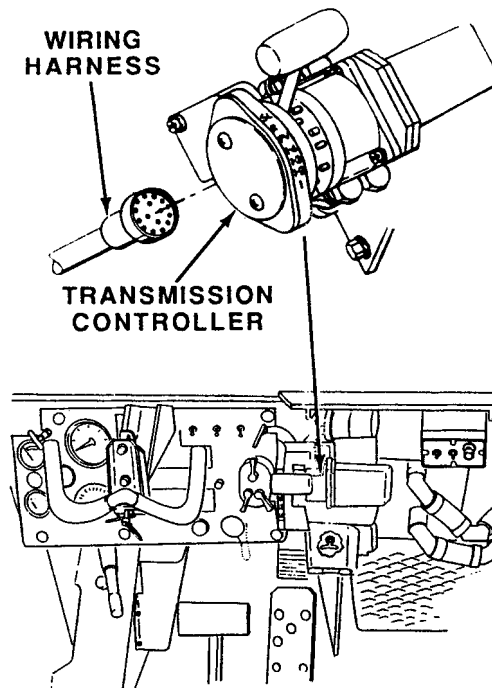

3. Pull tow start handle momentarily and release to engage transmission in 1-4 range. Close tow start handle cover and drive carrier to destination.

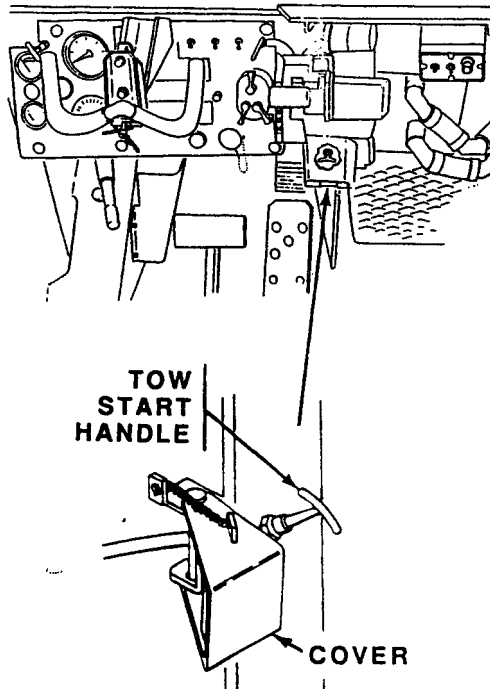

4. Stop engine (WP 0024 00).
5. Notify unit maintenance of defective transmission controller as soon as tactical situation permits.

END OF TASK

CONNECT TOWED LOAD

0048 00

THIS WORK PACKAGE COVERS:

Connect Towed Load (page 0048 00-1).

INITIAL SETUP:

Maintenance Level

Operator

Personnel Required

Driver (2)

Equipment Condition

Engine stopped (WP 0023 00), (WP 0024 00)
Carrier blocked (WP 0038 00)

CONNECT TOWED LOAD

NOTE

The carrier can tow equipment or a cargo trailer weighing up to 14,000 lbs (6,350 kg).

1. Position carrier so towing pintle lines up with pintle eye on drawbar or tow bar of load.
2. Remove locking pin, pull up on pintle latch, and open pintle.
3. Hook drawbar or tow bar eye on pintle, pull on latch, and close pintle.

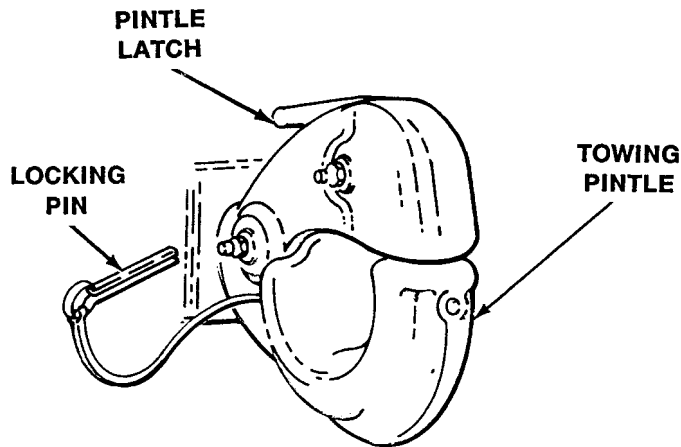

WARNING



Improper pintle lock pin installation may allow trailer to disengage; injuring personnel and causing extensive damage to the carrier and towed load. Bend pin end as required.

4. Make sure pintle latch is closed. Put in locking pin to secure latch. Bend pin end as required.

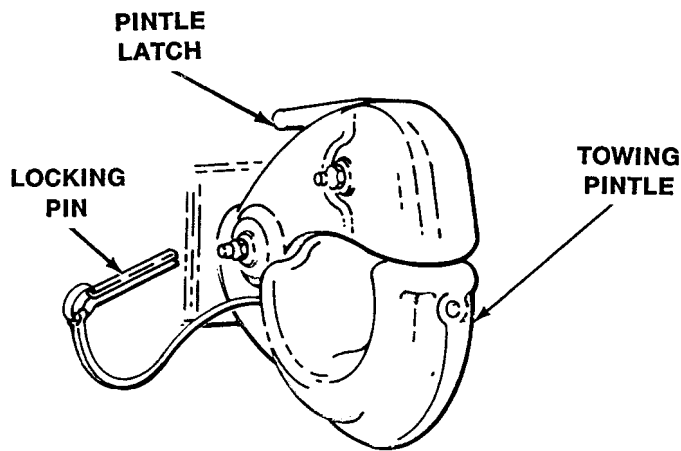

5. If towed trailer or equipment has an electrical connector, plug connector into carrier's trailer light receptacle. Then trailer's taillights and stoplights can work with carrier.

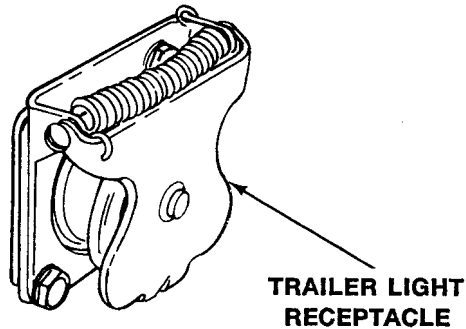

6. Connect towed load safety chain to shackles at rear of carrier.

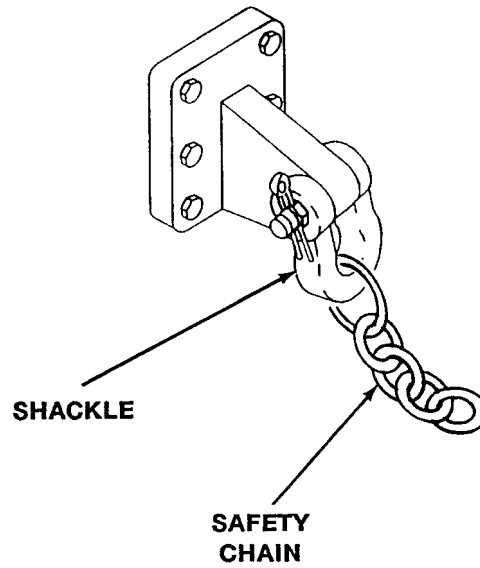

CAUTION

On M548A1 carriers, air brake kit must be installed when towing loads in excess of 3,000 lbs (1361 kg). If missing, notify unit maintenance

7. If carrier and towed equipment have air brake kits, connect air brakes (WP 0028 00).

END OF TASK

TOWING DISABLED CARRIER (M548A1)

0049 00

THIS WORK PACKAGE COVERS:

- Install Tow Bar on Disabled Carrier and Recovery Vehicle (page 0049 00-2).
 - Install Tow Cables on Disabled Carrier and Recovery Vehicle (page 0049 00-5).
 - Tow Disabled Carrier (page 0049 00-6).
 - Remove Tow Bar from Disabled Carrier and Recovery Vehicle (page 0049 00-8).
 - Remove Tow Cables from Disabled Carrier and Recovery Vehicle (page 0049 00-9).
-

INITIAL SETUP:

Maintenance Level

Operator

Equipment Condition

Recovery vehicle
Disabled carrier

Tools and Special Tools

- Tow Hook (2) (WP 0082 00, Item 1)
- Tow Cable (2) (WP 0082 00, Item 7)

Personnel Required

- Driver (2)
 - Helper (H) (4)
-

INSTALL TOW BAR ON DISABLED CARRIER AND RECOVERY VEHICLE**WARNING**

A towed carrier does not have steering until it reaches 3 mph (5 km/hr). Personnel can be killed or injured. Use tow bar or two tow cables. Use brakes to stop carrier, as necessary.

WARNING

Steering and braking control are lost when final drive shafts are disconnected. Personnel can be killed or injured. Do not use tow cables when drive shafts are disconnected.

WARNING

Carrier can roll and kill or injure personnel when final drive shafts are disconnected. Block tracks. Connect tow bar to disabled carrier and tow vehicle before disconnecting drive shafts.

CAUTION

If transmission is inoperable, or if final drive or track assembly is missing, transmission oil pumps will not operate. Serious damage will occur inside transmission. Do not tow carrier with drive shafts connected. Unit maintenance should disconnect drive shafts before towing carrier.

CAUTION

Carrier may be towed a maximum of 30 miles (48km) at 10 mph (16km/hr) or less when final drive to transmission drive shafts are connected. Damage to transmission will result if carrier is towed faster than 10 mph (16 km/hr) or further than 30 miles (48km).

NOTE

A small vehicle will not tow a larger one. Tow vehicle must be same size or larger than disabled carrier.

Personnel will disembark disabled carrier before towing operation begins when using tow bar. When using tow cables, driver will remain with carrier during towing operations.

Two helpers, one at left front and one at left rear of recovery vehicle, act as road guides. Two other helpers install tow bar.

1. Align rear of recovery vehicle with front of disabled carrier.
2. Remove two retainer clips and pins from tow bar.
3. Connect tow bar to towing eyes of disabled carrier and secure with two pins and retainer clips.

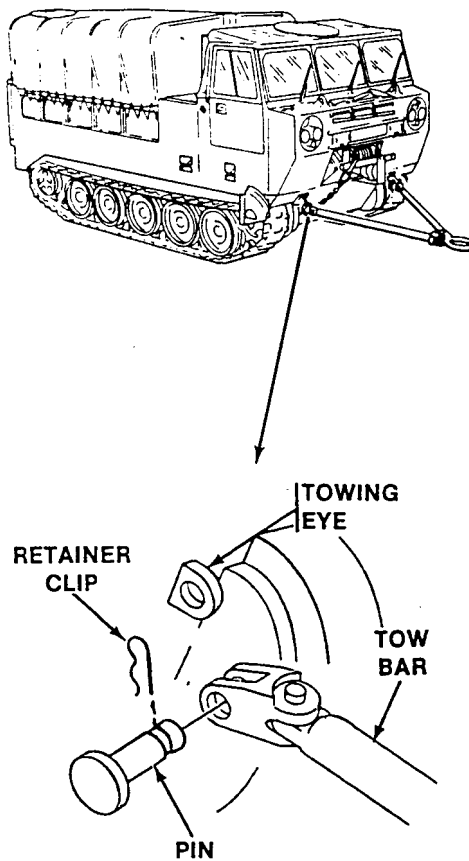

4. Remove cotter pin from tow pintle on recovery vehicle.
5. Pull up on pintle latch and open pintle.
6. Connect tow bar to tow pintle. Close tow pintle over tow bar. Check that tow pintle latches closed.
7. Install cotter pin to secure pintle latch closed.

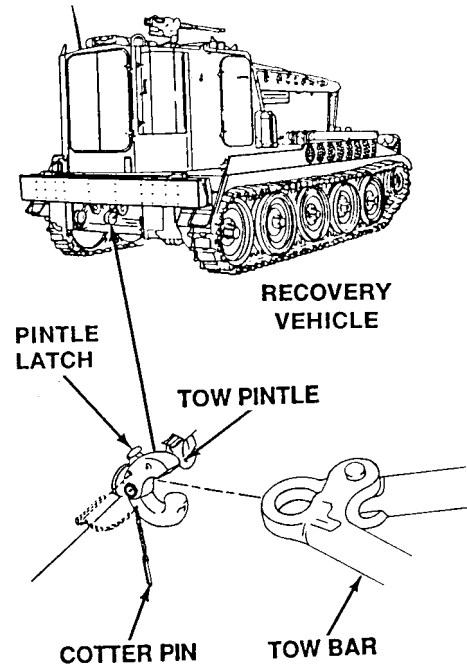

INSTALL TOW CABLES ON DISABLED CARRIER AND RECOVERY VEHICLE

WARNING



When towing with tow cables, do not disconnect disabled carrier's drive shafts between differential and final drives. Also, do not use cables to tow a carrier more than 30 miles (48km) or faster than 10 mph (16 km/hr).

NOTE

Left rear of recovery vehicle is connected to right front of disabled carrier. Right rear of recovery vehicle is connected to left front of disabled carrier.

1. Install two tow cables to tow hooks on front of disabled carrier and to tow hooks on rear of recovery vehicle in an X pattern.

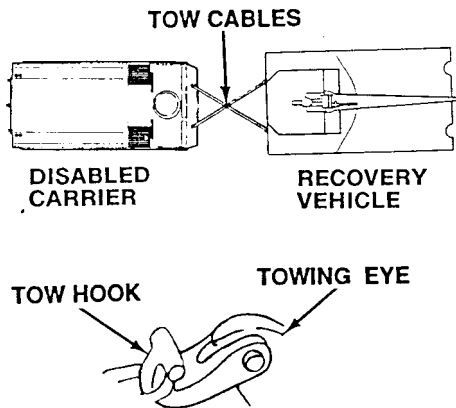

TOW DISABLED CARRIER

WARNING



Braking from high speeds when you tow with tow cables or tow bar can cause a jackknife which can injure personnel and damage equipment. Do not tow at speeds over 10 mph (16 km/hr) with tow bar.

WARNING

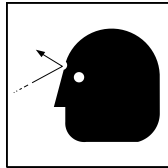

Tow cables can snap and injure personnel. Close all hatch covers before you use tow cables to tow carrier. Clear personnel out of danger area.

1. Unblock carrier tracks if blocked. See WP 0038 00.
2. Shift transmission range selector of disabled carrier to N range (WP 0004 00).

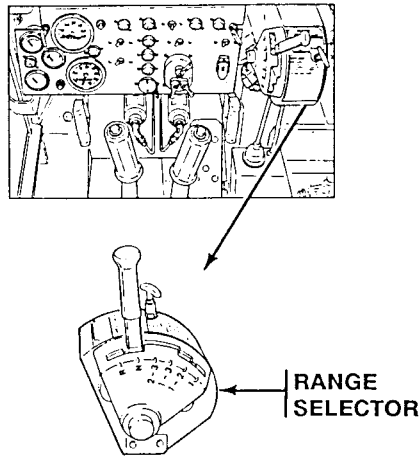

3. Release left and right steering levers in disabled carrier. Pull back on both levers so the lock buttons pop up, then ease the levers all the way forward.

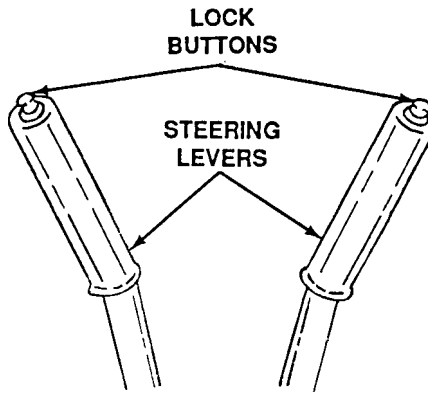

4. Start engine in recovery vehicle.

CAUTION

You will damage transmission and/or differential if you tow at speeds higher than 10 mph (16 km/hr) or for a distance of more than 30 miles (48 km). Have unit maintenance disconnect drive shaft between differential and final drives if you MUST tow faster than 10 mph (16 km/hr) or farther than 30 miles (48 km).

NOTE

Constant speed must be maintained while towing carrier.

5. Tow the carrier slowly. Do not exceed 10 mph (16 km/hr). Do not tow more than 30 miles (48 km).
6. Slowly bring both vehicles to a stop by releasing accelerator pedal in recovery vehicle.
7. Lock left and right steering levers in disabled carrier. Pull back on both levers and push the lock buttons down.

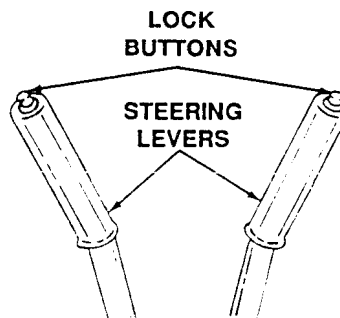

REMOVE TOW BAR FROM DISABLED CARRIER AND RECOVERY VEHICLE

1. Stop engine on recovery vehicle.
2. Remove cotter pin from tow pintle on recovery vehicle.
3. Pull up on pintle latch and open pintle.
4. Remove tow bar from tow pintle. Close tow pintle and check that tow pintle latches closed.
5. Install cotter pin to secure pintle latch closed.

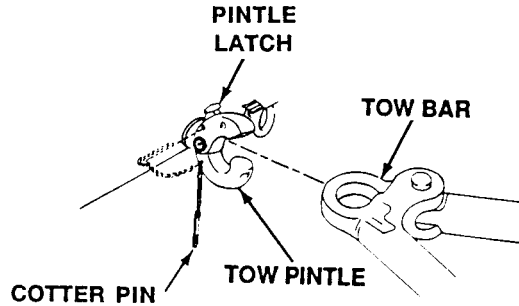

6. Remove two safety clips and pins securing tow bar to towing eyes of disabled carrier. Remove tow bar.
7. Install two pins in tow bar and secure with retainer clips.

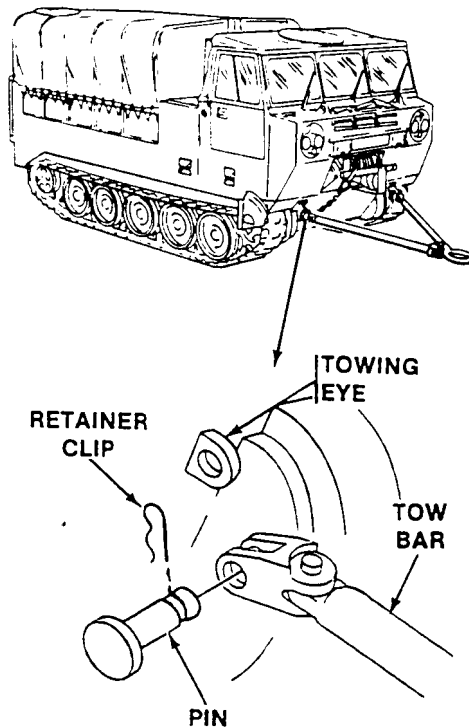

REMOVE TOW CABLES FROM DISABLED CARRIER AND RECOVERY VEHICLE

1. Drive recovery vehicle backward until tow cables are slack.
2. Stop engine on recovery vehicle.
3. Remove two tow cables from tow hooks on front of disabled carrier and from tow hooks on rear of recovery vehicle.

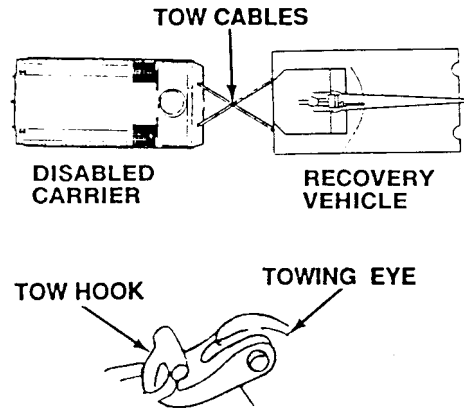
**END OF TASK**

TOWING DISABLED CARRIER (M548A3)

0050 00

THIS WORK PACKAGE COVERS:

- Install Tow Bar on Disabled Carrier and Recovery Vehicle (page 0050 00-2).
 - Install Tow Cables on Disabled Carrier and Recovery Vehicle (page 0050 00-4).
 - Tow Disabled Carrier (page 0050 00-5).
 - Remove Tow Bar from Disabled Carrier and Recovery Vehicle (page 0050 00-6).
 - Remove Tow Cables from Disabled Carrier and Recovery Vehicle (page 0050 00-8).
-

INITIAL SETUP:

Maintenance Level

Operator

Equipment Condition

Recovery vehicle
Disabled carrier

Tools and Special Tools

- Tow Hook (2) (WP 0082 00, Item 1)
- Tow Cable (2) (WP 0082 00, Item 7)

Personnel Required

- Driver (2)
 - Helper (H) (4)
-

INSTALL TOW BAR ON DISABLED CARRIER AND RECOVERY VEHICLE**WARNING**

A towed carrier does not have steering until it reaches 3 mph (5 km/hr). Personnel can be killed or injured. Use tow bar or two tow cables and use brakes to stop carrier, when necessary.

WARNING

Steering and braking control are lost when final drive shafts are disconnected. Personnel can be killed or injured. Do not use tow cables when drive shafts have been disconnected.

WARNING

Carrier could roll and kill or injure personnel when final drive shafts are disconnected. Block carrier tracks and connect tow bar to disabled carrier and to tow vehicle before disconnecting drive shafts.

CAUTION

If transmission is inoperable, or if final drive or track assembly is missing, the transmission oil pumps will not operate. Serious damage will occur inside the transmission. Do not tow carrier with drive shafts connected. Unit maintenance should disconnect drive shafts before towing carrier.

Carrier may be towed backwards a maximum of 1/4 mile (0.40 km) at 5 mph (8 km/hr) or less when final drive to transmission drive shafts are connected. Damage to transmission will result if carrier is towed backwards faster than 5 mph (8 km/hr) or further than 1/4 mile (0.40 km).

NOTE

A small vehicle will not tow a larger one. Tow vehicle must be same size or larger than disabled carrier.

Personnel will disembark disabled carrier before towing operation begins when using tow bar. When using tow cables, driver will remain with carrier during towing operations.

Two helpers, one at left front and one at left rear of recovery vehicle, act as road guides. Two other helpers install tow bar.

1. Align rear of recovery vehicle with front of disabled carrier.
2. Remove two retainer clips and pins from tow bar.
3. Connect tow bar to towing eyes of disabled carrier and secure with two pins and retainer clips.

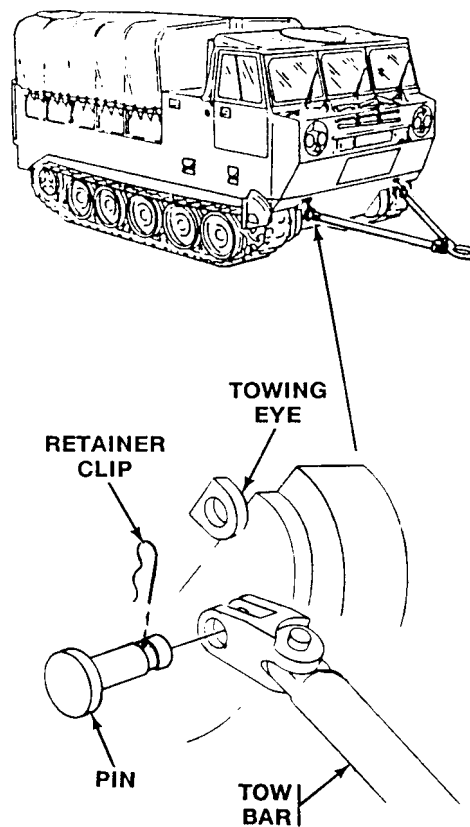

4. Remove cotter pin from pintle latch on recovery vehicle.
5. Pull up on pintle latch and open pintle.
6. Connect tow bar to tow pintle. Close tow pintle over tow bar. Check that tow pintle latches closed.
7. Install cotter pin to secure pintle latch closed.

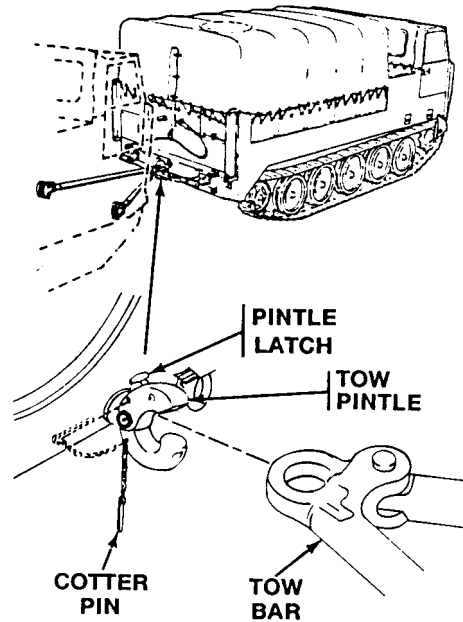

INSTALL TOW CABLES ON DISABLED CARRIER AND RECOVERY VEHICLE

NOTE

Left rear of recovery vehicle is connected to right front of disabled carrier. Right rear of recovery vehicle is connected to left front of disabled carrier.

1. Install two tow cables to tow hooks on front of disabled carrier and to tow hooks on rear of recovery vehicle in an X pattern.

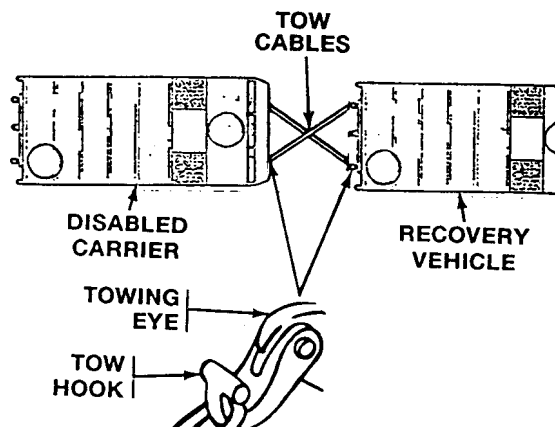

TOW DISABLED CARRIER

WARNING



Braking from high speeds when you tow with tow cables or tow bar can cause a jackknife, which can injure personnel and damage equipment. Do not tow at speeds over 15 mph (25 km/hr) with tow bar. Do not tow at speeds over 5 mph (8 km/hr) when in rough terrain, towing backward, or towing with tow cables.

WARNING

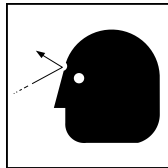

Tow cables can snap and injure personnel. Close all doors and covers before you use tow cables to tow carrier. Clear personnel out of danger area.

1. If blocked, unblock carrier tracks (WP 0038 00).
2. Place transmission controller in disabled carrier to SL.

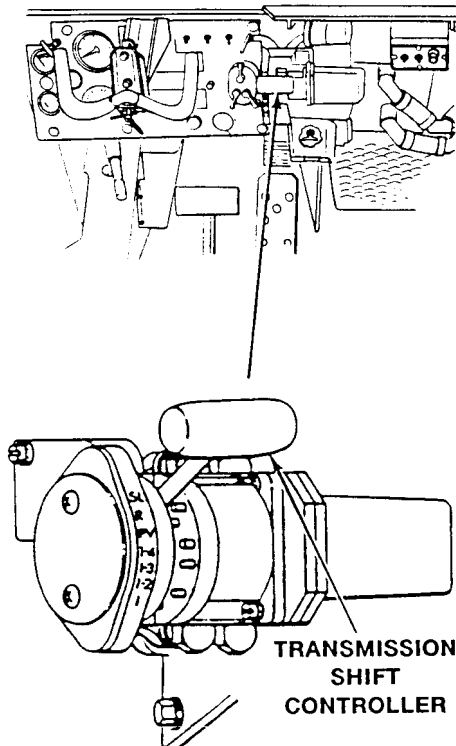

3. Release parking brake in disabled carrier (WP 0012 00).
4. Start engine in recovery vehicle.

NOTE

Constant speed must be maintained while towing carrier.

5. Drive recovery vehicle.
6. Slowly bring both vehicles to a stop by releasing accelerator pedal in recovery vehicle.
7. Set parking brake in disabled carrier (WP 0012 00).

REMOVE TOW BAR FROM DISABLED CARRIER AND RECOVERY VEHICLE

1. Stop engine on recovery vehicle.
2. Remove cotter pin from pintle latch on recovery vehicle.
3. Pull up on pintle latch and open pintle.
4. Remove tow bar from tow pintle. Close tow pintle and check that tow pintle latches closed.
5. Install cotter pin to secure pintle latch closed.

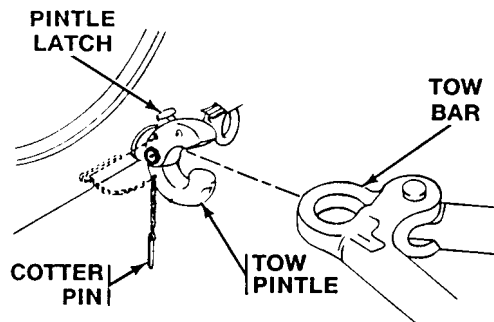

6. Remove two retainer clips and pins securing tow bar to towing eyes of disabled carrier. Remove tow bar.
7. Install two pins in tow bar and secure with retainer clips.

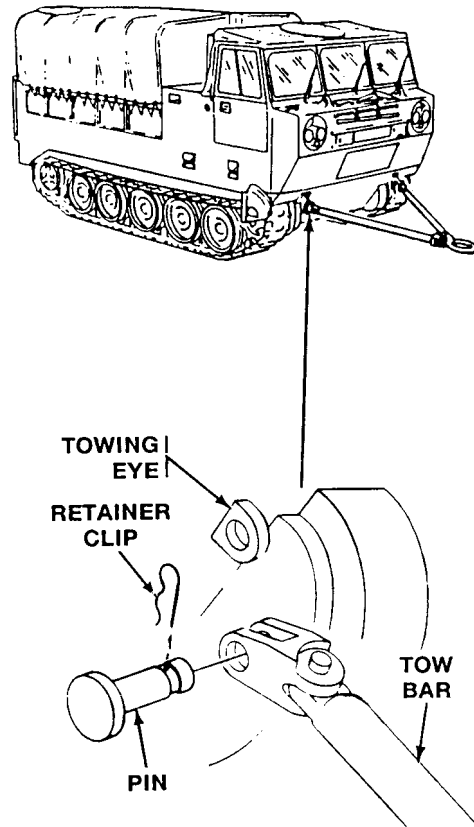

REMOVE TOW CABLES FROM DISABLED CARRIER AND RECOVERY VEHICLE

1. Drive recovery vehicle backward until tow cables are slack.
2. Stop engine on recovery vehicle.
3. Remove two tow cables from tow hooks on front of disabled carrier and from tow hooks on rear of recovery vehicle.

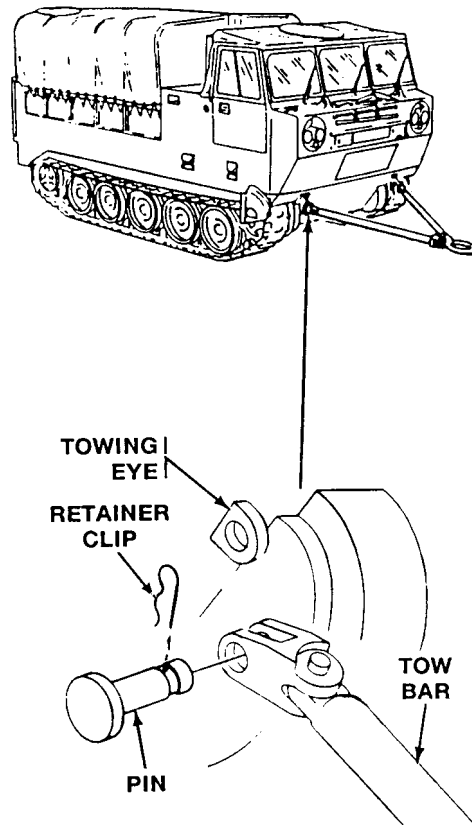
**END OF TASK**

TOW START DISABLED CARRIER (M548A1)

0051 00

THIS WORK PACKAGE COVERS:

Tow Start Disabled Carrier (page 0051 00-2).

INITIAL SETUP:

Maintenance Level

Operator

Personnel Required

Driver (2)

Tools and Special Tools

Tow Hook (WP 0082 00, Item 1)

Tow Cable (WP 0082 00, Item 7)

Equipment Condition

Disabled carrier

Recovery vehicle

TOW START DISABLED CARRIER (M548A1)

WARNING

Before hooking up a tow bar or disconnecting the drive shafts between the differential and final drives, chock the carrier with blocks so it cannot move.

WARNING

A towed carrier does not have steering until it reaches 3 mph (5 km/hr). Death or injury could result. Use tow bar or use brakes to stop carrier, when necessary.

NOTE

All personnel except driver will disembark disabled carrier before towing operation begins.

A carrier can be started by towing, if it can't be started normally or with a slave cable. To be safe, use a tow bar if one is available. If not, use two tow cables and tow hooks.

1. Connect tow bar or towing cables between disabled carrier and tow carrier (WP 0049 00).

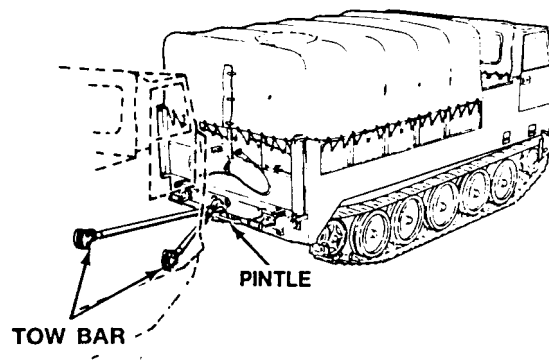

WARNING

Never touch the lock button while your carrier is moving. If you lock up the steering while moving, you could damage the carrier and hurt yourself as well.

4. Move out. Find a straight, flat stretch of road or ground and have the tow vehicle pull you at 20-25 mph (32-40 km/hr). When you get up to about 20 mph (32 km/hr), put the transmission range selector in 1-3 position and press the accelerator down about halfway.

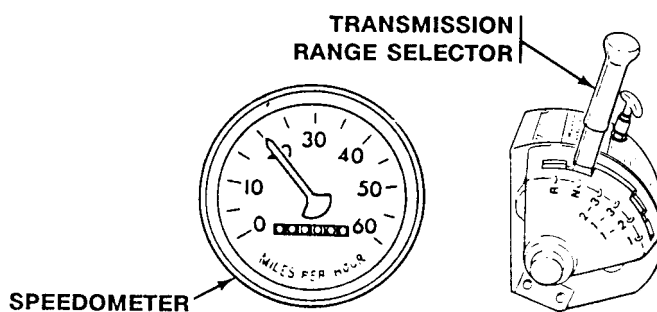
**NOTE**

Don't leave the transmission range selector in any driving range for more than about 5 seconds under tow. If the engine doesn't start, shift back to N range and let the transmission rest for a few seconds.

5. When your engine starts, move the transmission range selector to N range and signal the towing driver to stop. If you don't get a start in three tries, stop and troubleshoot your engine (WP 0055 00).

END OF TASK

TOW START DISABLED CARRIER (M548A3)

0052 00

THIS WORK PACKAGE COVERS:

Tow Start Disabled Carrier (page 0052 00-1).

INITIAL SETUP:

Maintenance Level

Operator

Personnel Required

Driver (2)

Tools and Special Tools

Tow Hook (WP 0081 00, Item 1)

Tow Cable (WP 0082 00, Item 7)

Equipment Condition

Disabled carrier

Recovery vehicle

TOW START DISABLED CARRIER (M548A3)

WARNING

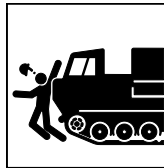

Before hooking up a tow bar or disconnecting the drive shafts between the differential and final drives, chock the carrier with blocks so it cannot move.

WARNING



A towed carrier does not have steering until it reaches 3 mph (5 km/hr). Death or injury could result. Use tow bar or use brakes to stop carrier, when necessary.

CAUTION

Do not start carrier without batteries installed. Starting engine with outside power and no batteries will damage voltage regulator.

NOTE

All personnel except driver will disembark disabled carrier before towing operation begins.

A carrier can be started by towing, if it can't be started normally or with a slave cable. To be safe, use a tow bar if one is available. If not, use two tow cables and tow hooks.

1. Connect tow bar or towing cables between disabled carrier and tow carrier (WP 0050 00).

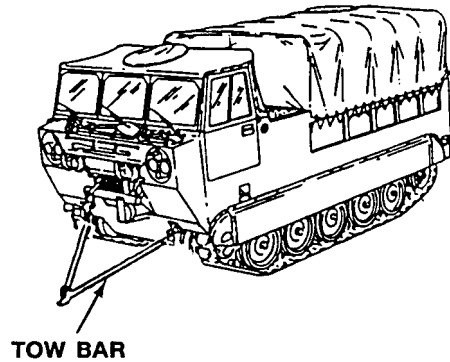

2. Turn MASTER SWITCH ON.

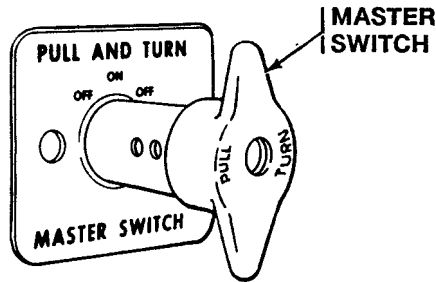

3. Push in fuel cutoff control.

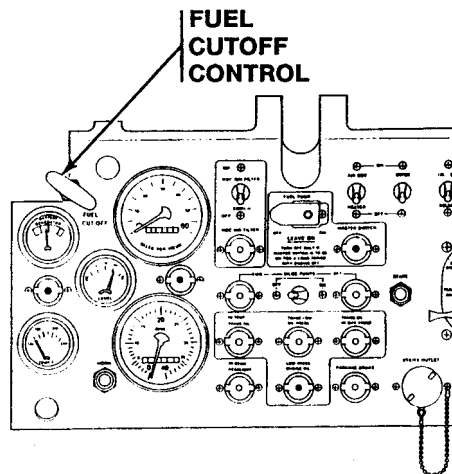

4. Remove steering wheel lock pin securing steering wheel in center position.

5. Place transmission shift controller in 1-4 range.

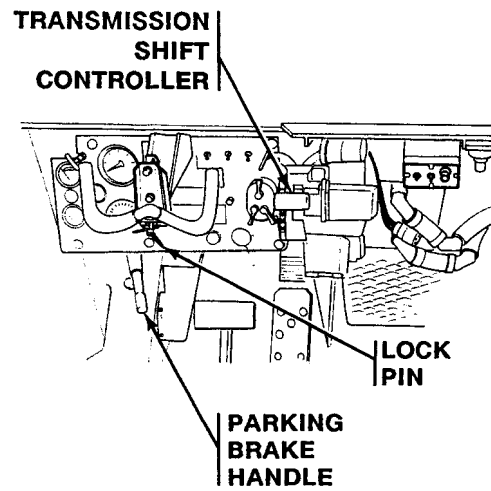

6. Push down on parking brake handle to release parking brake.

WARNING

If tow start handle is not pulled out before carrier begins to move, the engine could start in reverse causing damage to carrier and injury to personnel.

CAUTION

Do not tow a disabled carrier backward for a distance greater than 1/4 mile (0.4 km), or a speed greater than 5 mph (8 km/h). Serious damage to transmission will result.

NOTE

Carrier must be towed between 7 mph (11 km/h) and 14 mph (22 km/h) to start engine.

If tow start handle is released during tow, transmission will drop out of second gear lockup and engine will not turn over.

7. Open cover and pull tow start handle to engage transmission in second gear lockup. Signal driver of tow carrier to start.

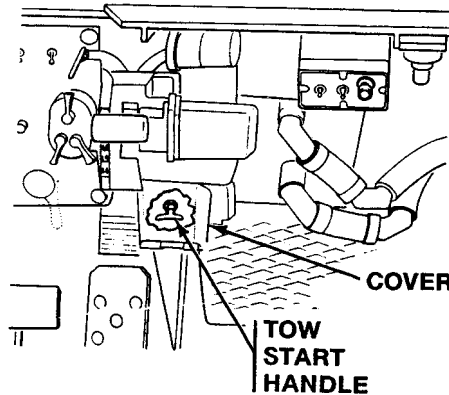

8. Hold tow start handle while carrier is being towed.
9. After engine starts, release tow start handle and close cover. Place transmission shift controller in SL (steering lock) and signal driver of tow carrier to stop.

END OF TASK

OPERATE NBC AIR FILTER SYSTEM (M548A3)

0053 00

THIS WORK PACKAGE COVERS:

Start (page 0053 00-2).
Stop (page 0053 00-5).

INITIAL SETUP:

Maintenance Level

Operator

Personnel Required

Driver

Soldier

References

TM 3-5

TM 3-4240-300-10-2

Unit SOP

Equipment Condition

Engine started (WP 0014 00)

START

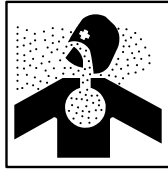
WARNING

Filters and masks of the NBC system will not protect you against carbon monoxide, ammonia, acid, or solvent fumes. Be sure the carrier is properly ventilated. Do not let any filters of the NBC system get wet. Water will destroy their ability to take the deadly chemical and biological NBC agents out of the air.

CAUTION

Operating NBC air filter system without engine running will discharge carrier batteries. Make sure engine is running while operating NBC air filter system.

NOTE

Do Steps 1 - 4 only when ordered to do so or when under actual NBC attack.

Spring clip must be raised from precleaner and particulate filter assembly openings for the gas particulate filter to operate at full capacity.

1. Raise spring clip from air intake openings on precleaner.

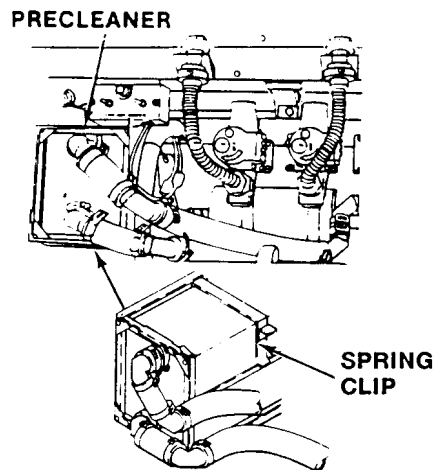

- Turn NBC AIR FILTER switch ON.

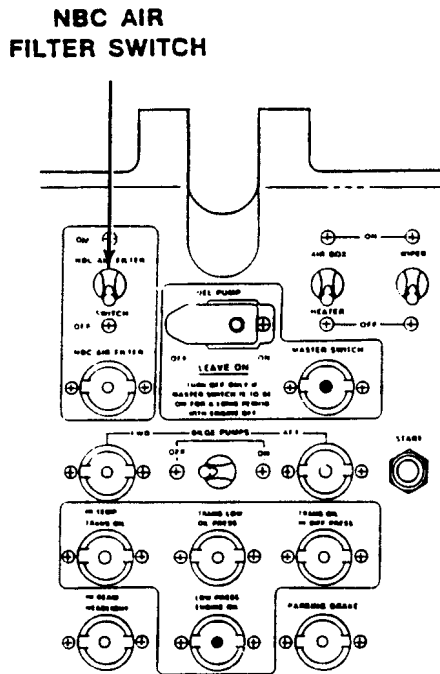

NOTE

Hold your breath while you put on and seal protective mask.

Detailed information concerning the protective mask can be found in TM 3-4240-300-10-2.

- Put on M42 protective mask.
- Clear and seal M42 protective mask.
- Pull out boom microphone connector from receptacle on helmet. Plug in protective mask microphone connector to receptacle on helmet.



WARNING

Under arctic conditions, danger of frostbite exists. Put on protective mask, but do not connect filtered air hose breakaway socket to protective mask canister unless carrier interior temperature is above 20° F (-7° C).

NOTE

Typically the M548A3 will have only four NBC stations. However, M548A3 vehicles converted from M730 vehicles may have five NBC stations.

6. Pull down sharply to remove air hose from orifice connector assembly. Hold your hand over air hose and feel if air flow is warm. If air is too cold to breathe safely, turn heater control knob to right (clockwise).

NOTE

It may take 15 to 20 minutes for air to heat to maximum temperatures.

7. When air is warm enough to breathe safely, connect air hose to canister of M42 protective mask.

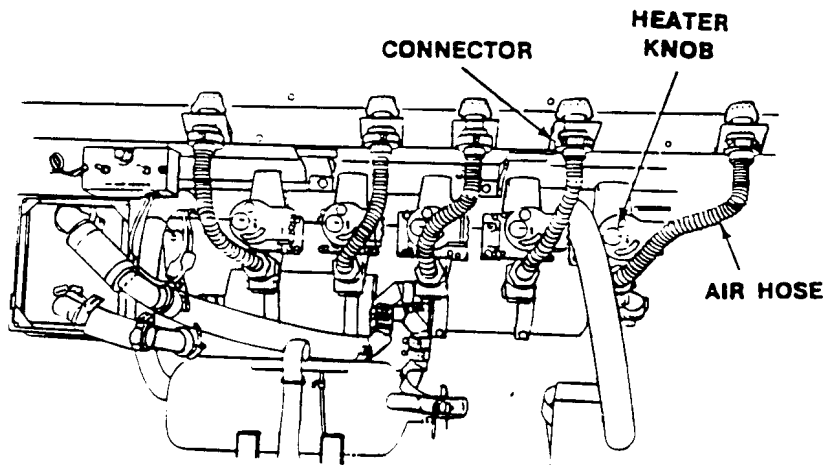

STOP

1. Place NBC AIR FILTER switch OFF.

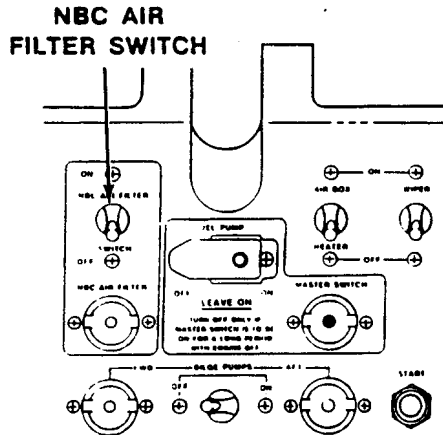

WARNING

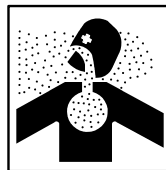

After Nuclear, Biological, or Chemical (NBC) exposure of the M548A3 carrier, handle all air filters with extreme caution. Unit commander or officer in charge of personnel assigned to remove and dispose of contaminated filters must prescribe necessary protective clothing to be worn. Crew members may assist only if wearing protective clothing. Safety measures including decontamination operation must be performed IAW TM 3-5.

Failure to decontaminate and wear protective clothing could result in serious health hazards to personnel. Unprotected personnel may experience injury or death if residual toxic agents or radioactive material are present. If an M548A3 carrier is exposed to chemical or biological agents, servicing personnel must wear protective overgarment, mask, hood, and chemical protective gloves and boots. Place all contaminated air filters into double lined plastic bags. Move them swiftly away from the work site. The same procedure applies for radioactive dust contamination. However, the company NBC Team should measure radiation prior to filter removal to determine extent of safety procedures required per NBC Annex to Unit Standard Operation Procedures (SOP). The segregation area in which contaminated air filters are temporarily stored must be marked with appropriate NBC placards. Make final disposal of contaminated air filters in accordance with local SOP. NBC contaminated filters must be handled using adequate precautions and must be disposed of by trained personnel.

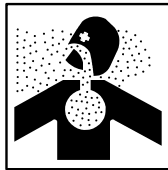
WARNING

Use extreme caution **AT ALL TIMES** when handling DS2. DS2 is a combustible solution. Severe chemical burns can result if personnel fail to observe all safety precautions. DS2 can damage eyes and skin, and if inhaled, can cause illness. DS2 can damage the NBC protective overgarment. Long term contact with DS2 (about 24 hours) can damage the NBC protective gloves, hood and overboots.

To avoid injury:

Wear protective clothing including mask, hood, and rubber gloves **AT ALL TIMES** when handling DS2 in a contaminated environment. If available, wear M2 Toxicological Agent Protective Apron. In extreme cold temperatures, wear rubber gloves **INSIDE** arctic mittens. Change mittens if they become soaked with DS2 since DS2 can damage rubber gloves.

DO NOT allow DS2 to spray on personnel.

DO NOT allow DS2 to spray on protective clothing.

DO NOT spray DS2 on hot exhaust, hot surfaces, or open flames, as it can cause fire.

DO NOT use DS2 to decontaminate personnel. It is harmful to the skin and eyes.

DO NOT inhale DS2 fumes, you may start coughing and become ill.

DO NOT use the M13 DAP if the container is damaged or leaking.

DO NOT use the DS2 filled, green painted container for training.

DS2 makes surfaces slippery; use caution to avoid falling.

Keep fluid container on the same level as operator is standing, as it can tip over and cause injury.

M13 DAP filled with DS2 weighs 54 lbs (24.5 kgs). Be careful to avoid injury to people when lifting it 4 ft (1.2 m) or higher.

Emergency treatment for DS2 contact is as follows:

SKIN. Remove it from skin by wiping and then flush the affected area with water. DS2 may not give any immediate reaction. Therefore, wash the area even if no discomfort is felt or no irritation is noted.

EYES. Flush them with large amounts of water immediately. After flushing eyes for 20 to 30 minutes, seek medical attention. DS2 can damage eyes after a few seconds of exposure.

MOUTH. If swallowed, rinse mouth out immediately and spit out, then drink large amounts of water and seek medical attention immediately. **DO NOT INDUCE VOMITING.**

NOSE (fumes). If you inhale enough DS2 to cause coughing, leave the area immediately. If breathing difficulties continue, seek medical attention.

2. Remove M42 protective mask.

3. Turn heater control knob left (counter-clockwise) to OFF position.
4. Disconnect air hose from canister of M42 protective mask.
5. Install air hose assembly on orifice connector assembly.

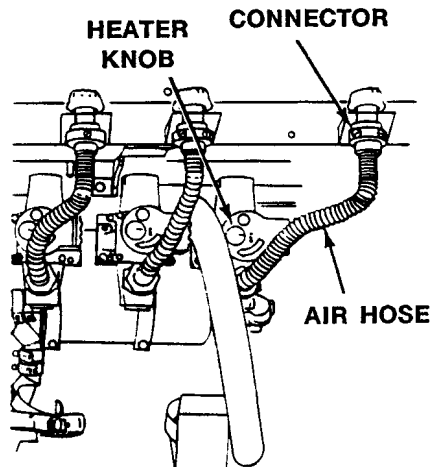
**NOTE**

Typically, the M548A3 will have only four NBC stations. However, M548A3 vehicles converted from M730 vehicles may have five NBC stations.

6. Pull protective mask microphone connector from receptacle on helmet and plug in boom microphone connector to receptacle on helmet.



7. Press spring clip down over air intake openings on precleaner.

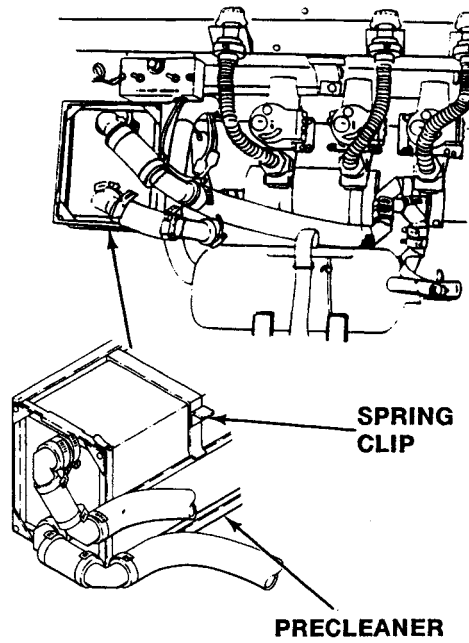

END OF TASK

CHAPTER 3

OPERATOR TROUBLESHOOTING PROCEDURES

WORK PACKAGE INDEX

<u>Title</u>	<u>Sequence No.</u>
INTRODUCTION TO TROUBLESHOOTING.....	0054 00
TROUBLESHOOTING SYMPTOM INDEX.....	0055 00
TROUBLESHOOTING TABLE.....	0056 00

INTRODUCTION TO TROUBLESHOOTING

0054 00**GENERAL**

The Troubleshooting table lists common malfunctions found while operating or servicing the M548A1 and M548A3 and its components. The troubleshooting table is divided into sections. Each section covers malfunctions common to the different systems of the carrier (e.g., engine, transmission, and electrical, etc.).

The TROUBLESHOOTING TABLE has three divisions: MALFUNCTION, TEST OR INSPECTION, and CORRECTIVE ACTION. The MALFUNCTIONS are numbered in sequence through the TROUBLESHOOTING TABLE. The MALFUNCTION is what will bring you to the TROUBLESHOOTING TABLE.

TEST OR INSPECTION is a step you take to isolate the MALFUNCTION. Each TEST OR INSPECTION has a CORRECTIVE ACTION. You should perform the TEST or INSPECTION and CORRECTIVE ACTION in the order listed.

The TROUBLESHOOTING TABLE for the M548A1 and M548A3 are listed in the symptom index (WP 0055 00).

The manual cannot list all possible malfunctions, nor all the tests or inspections and corrective actions. It is essential that you record all faults on DA Form 2404 and report them to unit maintenance. If a malfunction is not listed, or is not corrected by the listed corrective action, notify unit maintenance.

TROUBLESHOOTING SYMPTOM INDEX

0055 00

AIR BRAKE KIT (M548A1)

- No Brake Response When You Step on Treadle Valve Pedal005600-1
- Air Brakes Don't Release005600-1

BILGE PUMP

- Bilge Pump Does Not Work With The BILGE PUMP Switch On005600-3

DIFFERENTIAL (M548A1)

- DIFFERENTIAL OIL HI TEMP Warning Light On005600-5

ELECTRICAL SYSTEM

- No Battery Current005600-7
- Batteries Discharged005600-7
- With MASTER SWITCH ON, Indicator Light Does Not Light005600-7

ENGINE

- Engine Doesn't Crank When You Press Start Switch005600-9
- Engine Cranks But Does Not Start005600-9
- Engine Cranks But Does Not Start When Temperature is Below +40°F (+4°C)
and Air Box Heater is Used005600-10
- Engine Cranks Too Slow to Start005600-10
- Engine Labors, Runs Rough, Stalls, or Does Not Put Out Full Power005600-10
- Engine Overheats005600-11
- ENGINE OIL HI TEMP-LOW PRESS (M548A1) or ENGINE OIL LOW
PRESS (M548A3) Warning Light Comes On005600-12
- ENGINE COOLANT LOW LEVEL Warning Light Comes On005600-12

ENGINE COOLANT HEATER (M548A3) KIT (M548A1)

- Engine Coolant Heater Does Not Start With RUN-OFF START Switch Held
in Start Position005600-13
- Coolant Heater Overheats005600-13
- Coolant Heater Output Too Low005600-13
- Batteries Overheat005600-13

FINAL DRIVE

- Final Drive Runs Hot005600-15

MACHINE GUN MOUNTING KIT (M66 MOUNT) (M548A1/M548A3)

- Machine Gun Hard to Traverse005600-17
- Mount Hard to Traverse005600-17
- Machine Gun With Ammunition Doesn't Balance Right005600-17

TROUBLESHOOTING SYMPTOM INDEX—Continued**0055 00****MATERIAL HANDLING KIT**

Hoist Beam Won't Go All The Way Back For Loading	0056 00-19
Trolley Hoist Doesn't Ride Freely On The Beam	0056 00-19
Support Retaining Pin Works Loose While You're Driving The Carrier	0056 00-19

NBC KIT (M548A3)

Gas Particulate Filter Unit Does Not Work	0056 00-21
Lack of Air flow At Crew Station	0056 00-21
Air Heater Does Not Heat Filtered Air	0056 00-21

TRACKS AND SUSPENSION

Carrier Pulls to One Side	0056 00-23
Carrier Throws Track	0056 00-23
Too Much Noise in Track of Suspension	0056 00-23
Carrier Rides Too Hard	0056 00-24

TRANSFER GEARCASE (M548A1)

No Power Through Transfer Gearcase When Engine Is Running	0056 00-25
Transfer Gearcase Runs Hot and Noisy	0056 00-25

TRANSMISSION

Carrier Does Not Move In Any Range	0056 00-27
TRANS OIL HI TEMP Warning Light Comes On (M548A1)	0056 00-27
TRANSMISSION LOW OIL PRESSURE Warning Light Comes On (M548A3)	0056 00-28

TURN SIGNAL KIT

Lights Don't Flash With Control Lever in Operating Position	0056 00-29
---	------------

VEHICLE COMPARTMENT HEATER KIT

Heater Does Not Start With RUN-OFF-START Switch Held in START Position	0056 00-31
Heater Overheats and Stops	0056 00-31
Heater Overheats and Doesn't Stop	0056 00-31
Heater Does Not Put Out Enough Heat	0056 00-31

WINCH (M548A1)

Winch Does Not Work With Power Takeoff Engaged	0056 00-33
Winch Drum Doesn't Turn With Clutch Handle Disengaged	0056 00-33

TROUBLESHOOTING TABLE

0056 00

INITIAL SETUP:

Maintenance Level

Operator

AIR BRAKE KIT

NOTE

If you find something seriously wrong that is not listed in this table or that you are unable to fix with these instructions, notify unit maintenance.

MALFUNCTION	TEST OR INSPECTION	CORRECTIVE ACTION
1. NO BRAKE RESPONSE WHEN YOU STEP ON TREADLE VALVE PEDAL	1. Check if air reservoir drain cock is open. 2. Check if service cutoff cock is closed.	Close the drain cock. Open the service cutoff cock.
2. AIR BRAKES DON'T RELEASE.	1. Check for low pressure in the air brake kit. 2. Check if emergency cutoff cock is closed. 3. Check if air couplings are hooked up wrong.	Run the engine to build up pressure before you move the towed load. Open emergency cutoff cock. Hook air coupling up right.

TROUBLESHOOTING TABLE — Continued

0056 00

INITIAL SETUP:

Maintenance Level

Operator

BILGE PUMP

MALFUNCTION	TEST OR INSPECTION	CORRECTIVE ACTION
<p>1. BILGE PUMP DOES NOT WORK WITH THE BILGE PUMP SWITCH ON.</p>	<p>1. Check if MASTER SWITCH is OFF. 2. Check if bilge pump strainer or outlet is clogged. 3. Check if bilge pump vent is blocked.</p>	<p>Turn MASTER SWITCH ON. Clean bilge pump strainer or outlet (WP 0073 00). Clean bilge pump vent (WP 0073 00). If you can't get to the bilge pump to clean it because of a load in the cargo compartment, cycle the bilge pump switch ON and OFF a few times. That usually starts the pump.</p>

INITIAL SETUP:

Maintenance Level

Operator

DIFFERENTIAL (M548A1)

MALFUNCTION	TEST OR INSPECTION	CORRECTIVE ACTION
1. DIFFERENTIAL OIL HI TEMP WARNING LIGHT COMES ON.	<p style="text-align: center;"><u>CAUTION</u></p> <p>Do not operate carrier if differential oil HI-TEMP warning light comes on.</p> <ol style="list-style-type: none"> 1. Check for low differential oil level. 2. Check if quick disconnect coupling in differential lube line is improperly connected. 	<p>Add oil as needed (WP 0057 00).</p> <p>Connect quick disconnect coupling properly.</p>

INITIAL SETUP:

Maintenance Level

Operator

ELECTRICAL SYSTEM

MALFUNCTION	TEST OR INSPECTION	CORRECTIVE ACTION
1. NO BATTERY CURRENT.	<ol style="list-style-type: none"> 1. Check if battery cable connectors are loose, disconnected, or corroded. 2. Inspect for low water level in battery. 	<p>Attach disconnected connectors and tighten loose connectors. If connectors are corroded, notify unit maintenance.</p> <p>If water level is low, notify unit maintenance.</p>
2. BATTERIES DISCHARGED.	<ol style="list-style-type: none"> 1. Check if battery water level is low (WP 0070 00). 2. Using electrical equipment when the engine is not running. 3. Check to see if battery cable connectors are loose, disconnected, or corroded. 4. Check engine generator drive belt. 	<p>If water level is low, add distilled water as needed.</p> <p>Run the engine periodically to recharge the batteries.</p> <p>Fix loose, disconnected, or corroded connectors. If connectors are corroded, notify unit maintenance.</p> <p>If belt is loose, broken, or missing, notify unit maintenance.</p>
3. WITH MASTER SWITCH ON, INDICATOR LIGHT DOES NOT LIGHT.	<ol style="list-style-type: none"> 1. Lamp may be burned out or there are loose connections in the lamp leads. 2. Check battery indicator gauge to see if batteries are dead. Check for faulty or loose battery connectors. 	<p>If battery gauge shows usual readings (WP 0018 00 or WP 0019 00), and other electrical equipment and lights are working, lamp is faulty. You can drive carrier, but be sure to turn MASTER SWITCH OFF when you shut down carrier. Notify unit maintenance of faulty lamp.</p> <p>Tighten loose battery cable connectors. If you have to operate carrier with dead batteries, tow start (WP 0051 00 or WP 0052 00), or use an outside power source (WP 0015 00) to start the engine. Notify unit maintenance.</p>

INITIAL SETUP:

Maintenance Level

Operator

ENGINE

MALFUNCTION	TEST OR INSPECTION	CORRECTIVE ACTION
1. ENGINE DOES NOT CRANK WHEN YOU PRESS START SWITCH.	1. Check if MASTER SWITCH is OFF.	Turn MASTER SWITCH ON.
	2. Check if transmission range selector (M548A1) is not in N position.	Place transmission range selector (M548A1) in N position (WP 0020 00).
	3. Check if transmission shift controller (M548A3) is in the SL position.	Place transmission shift controller (M548A3) in SL position (WP 0021 00).
	4. Check if batteries are in good condition.	Troubleshoot electrical system (WP 0055 00).
	5. Check for faulty engine, transmission, or transfer gearcase.	Disengage the engine disconnect and try to start. If engine cranks, transmission or transfer gearcase is faulty. Notify unit maintenance.
2. ENGINE CRANKS BUT DOES NOT START.	1. Check if fuel cutoff control handle is pulled out.	Push fuel cutoff control handle in (WP 0013 00 or WP 0014 00).
	2. Check if fuel pump switch is OFF.	Turn fuel pump switch on and close switch cover (WP 0013 00 or WP 0014 00).
	3. Check if there is enough fuel in fuel tank.	Refuel carrier (WP 0025 00).
	4. Check if temperature is colder than 40°F (4°C) and air box heater is not being used.	Use air box heater (WP 0039 00).
	5. Check if there is water in the fuel.	Drain primary and secondary fuel filters (WP 0069 00).
	6. Check if not enough air is getting to engine (M548A1)	Clean air cleaner element (WP 0063 00).
	7. Check if air cleaner indicator has red in the window.	Notify unit maintenance.
	8. Check if tow start handle (M548A3) is pulled out.	Push tow start handle in (WP 0052 00).

MALFUNCTION	TEST OR INSPECTION	CORRECTIVE ACTION
3. ENGINE CRANKS BUT DOES NOT START WHEN TEMPERATURE IS BELOW 40°F (4°C) AND AIR BOX HEATER IS USED.	1. Check for leaks in air box heater fuel lines or connections (M548A1).	Tighten any loose connections. Notify unit maintenance.
4. ENGINE CRANKS TOO SLOW TO START.	1. (M548A3) Troubleshoot electrical system (WP 0055 00).	(M548A1) Use outside power source (WP 0015 00) or tow start (WP 0051 00) carrier. If the cause of slow cranking is not obvious, have unit maintenance troubleshoot the electrical system (WP 0055 00).
<p>CAUTION</p> <p>Never move the engine disconnect handle when the engine is running.</p>		
5. ENGINE LABORS, RUNS ROUGH, STALLS, OR DOES NOT PUT OUT FULL POWER.	2. Temperature is colder than -25°F and engine disconnect is not disengaged.	Disengage engine disconnect (WP 0039 00).
	1. Check if engine (M548A1) is getting enough air.	Clean air cleaner element (WP 0063 00).
	2. Check if air cleaner indicator has red in window.	Notify unit maintenance.
	3. Check if there is water in fuel.	Drain primary and secondary fuel filters and air separator tank (WP 0069 00).
	4. High elevation operation.	The carrier usually loses power at high elevations (mountain passes or high plateaus). If carrier runs rough or power loss is bad, notify unit maintenance.
6. ENGINE OVERHEATS.	<p>CAUTION</p> <p>Driving carrier with an overheated engine can damage engine. When ENGINE COOLANT TEMPERATURE GAUGE indicates above 230°F (110°C), stop carrier and run engine at 1000 to 1200 rpm until coolant temperature drops below 230°F (110°C).</p>	

MALFUNCTION	TEST OR INSPECTION	CORRECTIVE ACTION
	<ol style="list-style-type: none"> 1. Is engine hard running in hot weather? 2. Check if coolant level is low. 3. Check if radiator cap is not sealed right. 4. Check if there is enough air moving through intake grille and radiator. 5. Check if coolant fan (M548A1) is working right. 6. Check coolant fan drive system (M548A3). 7. Check if engine oil level is low. 8. Check if all power plant access panels (M548A3) are in place and mounting clamps are tight. 	<p>Follow the precautions for driving in extreme heat (WP 0046 00). When engine overheats, stop carrier and run engine at 1000 to 1200 rpm until coolant temperature drops below 230°F (110°C).</p> <p>Add coolant as needed (WP 0065 00 or WP 0066 00). Check for coolant leaks. If you find any leaks, notify unit maintenance.</p> <p>Make sure the cap is on straight and tight (WP 0065 00 or WP 0066 00). If cap is damaged or seal is broken, notify unit maintenance.</p> <p>Remove any debris from intake grille, exhaust grille, and radiator fins.</p> <p>Look for loose or broken fan belts (WP 0067 00). If any belt is broken, worn, or loose, notify unit maintenance.</p> <p>Stop engine (WP 0024 00). Remove power plant rear access panel (WP 0036 00). If coolant fan belt is loose or missing, do not operate carrier. Notify unit maintenance.</p> <p>Install rear power plant access panel (WP 0036 00). Start engine (WP 0014 00). Drive carrier under similar condition of reported overheat. If engine overheats, stop engine immediately (WP 0024 00). Notify unit maintenance.</p> <p>Add oil as needed (WP 0057 00).</p> <p>Install panels (WP 0036 00).</p>

MALFUNCTION	TEST OR INSPECTION	CORRECTIVE ACTION
<p>7. ENGINE OIL HI-TEMP-LO-PRESS (M548A1) or ENGINE OIL LOW PRESS (M548A3) WARNING LIGHT COMES ON.</p>	<p style="text-align: center;">CAUTION</p> <p>Do not operate carrier if oil HI-TEMP-LO-PRESS (M548A1) ENGINE OIL LOW PRESS (M548A3) warning light comes on with engine running. Engine can be damaged. If ENGINE OIL LOW PRESS or HI-TEMP-LO-PRESS warning light does not go off within 5-10 seconds after engine starts, stop engine (WP 0023 00 for M548A1 and WP 0024 00 for M548A3.)</p> <ol style="list-style-type: none"> 1. Check for low engine oil level. 2. Check if engine is overheating. 	<p>Add oil as needed (WP 0057 00). See ENGINE OVERHEATS (0056 00-9).</p>
<p>8. ENGINE COOLANT LOW LEVEL WARNING LIGHT COMES ON (M548A3).</p>	<ol style="list-style-type: none"> 1. Check if coolant level is low. 2. Check for coolant leaks. 	<p>Add coolant as needed (WP 0066 00). If you find any leaks, notify unit maintenance.</p>

INITIAL SETUP:

Maintenance Level

Operator

ENGINE COOLANT HEATER KIT

MALFUNCTION	TEST OR INSPECTION	CORRECTIVE ACTION
1. COOLANT HEATER DOES NOT START WITH RUN-OFF-START SWITCH HELD IN START POSITION.	1. Check if MASTER SWITCH is OFF. 2. Defective heater.	Turn MASTER SWITCH ON. Notify unit maintenance.
2. COOLANT HEATER OVERHEATS.	1. Check if one or both coolant shutoff valves are closed. 2. Defective heater.	Open coolant shutoff valves (WP 0040 00 or WP 0041 00). Notify unit maintenance.
3. COOLANT HEATER OUTPUT IS TOO LOW.	1. Check if the HI-LO switch is in LO position.	Move HI-LO switch to HI position (WP 0040 00 or WP 0041 00).
4. BATTERIES OVERHEAT.	1. Air temperature is too warm to need the engine coolant heater. 2. Engine and engine coolant heater are both running.	Turn off engine coolant heater (WP 0040 00 or WP 0041 00). You do not need to use heater if temperature is above -25°F (-32°C). Turn off engine coolant heater (WP 0040 00 or WP 0041 00) as soon as the engine starts.

TROUBLESHOOTING TABLE — Continued

0056 00

INITIAL SETUP:

Maintenance Level

Operator

FINAL DRIVE

MALFUNCTION	TEST OR INSPECTION	CORRECTIVE ACTION
1. FINAL DRIVE RUNS HOT.	1. Check if final drive oil level is low.	Add oil as needed (WP 0057 00).

TROUBLESHOOTING TABLE — Continued

0056 00

INITIAL SETUP:

Maintenance Level

Operator

**MACHINE GUN MOUNTING KIT
(M548A1/M548A3)**

MALFUNCTION	TEST OR INSPECTION	CORRECTIVE ACTION
1. MACHINE GUN HARD TO TRAVERSE.	1. Check if pintle traverse lock is partly engaged (WP 0074 00). 2. Check if pintle or pintle socket is dirty, rusty, or burred.	Clean the pintle or pintle socket (WP 0074 00). Remove any burrs.
2. MOUNT HARD TO TRAVERSE.	1. Check if brake assembly is partly locked.	Unlock the brake assembly (WP 0074 00).
3. MACHINE GUN WITH AMMUNITION DOESN'T BALANCE RIGHT.	1. Check if equilibrator spring is not adjusted right.	Adjust spring (WP 0074 00).

INITIAL SETUP:

Maintenance Level

Operator

MATERIAL HANDLING KIT (M548A1/M548A3)

MALFUNCTION	TEST OR INSPECTION	CORRECTIVE ACTION
1. HOIST BEAM WON'T GO ALL THE WAY BACK FOR LOADING.	1. Check if hoist beam locks are engaged. 2. Check if hoist beam is installed backwards.	Disengage hoist beam locks (WP 0029 00). Remove beam and install it correctly.
2. TROLLEY HOIST DOESN'T RIDE FREELY ON THE BEAM (WP 0029 00).	1. The trolley lock is partly engaged.	Disengage the trolley lock (WP 0029 00).
3. SUPPORT RETAINING PIN WORKS LOOSE WHILE YOU'RE DRIVING THE CARRIER.	1. The retaining pin isn't held right by the retainer or locking spring.	Install the support retaining ring correctly (WP 0029 00).

TROUBLESHOOTING TABLE — Continued

0056 00

INITIAL SETUP:

Maintenance Level

Operator

NBC KIT (M548A3)

MALFUNCTION	TEST OR INSPECTION	CORRECTIVE ACTION
<p>1. GAS PARTICULATE FILTER UNIT DOES NOT WORK.</p>	<p>1. Check circuit breaker for gas particulate filter unit.</p> <p>2. Listen for precleaner and particulate filter assembly blower motor operation.</p> <p>3. Check to see if precleaner and particulate filter assembly electrical cable and ground are connected.</p> <p>4. Check condition and connection of filter air hose assembly.</p> <p>5. Check operation of filter unit.</p>	<p>If circuit breaker is at OFF position, place it to ON position (WP 0053 00). If motor is not working, go to Step 2 page 0056 00-21. If circuit breaker is at ON, go to Step 2 page 0056 00-21.</p> <p>If operating, go to Step 4 page 0056 00-21. If they are not operating, go to Step 3 page 0056 00-21.</p> <p>If loose or not connected, connect (WP 0053 00). If connected, go to Step 4 page 0056 00-21.</p> <p>If filtered air hose is pinched or blocked, remove obstructions. Notify unit maintenance.</p> <p>If gas particulate filter still does not work, notify unit maintenance.</p>
<p>2. LACK OF AIR FLOW AT CREW STATION.</p>	<p>1. Check to see if spring clip is down over air intake openings on air purifier.</p> <p>2. Check to see if air hoses are kinked or pinched.</p> <p>3. Check to see if there are any loose air hose connections.</p> <p>4. Check to see if precleaner motor is operating. If motor is not operating, check if electrical cable at precleaner is connected properly.</p>	<p>Raise spring clip from air intake openings on air purifier (WP 0053 00).</p> <p>Straighten or replace air hoses (WP 0053 00).</p> <p>Tighten loose connections (WP 0053 00).</p> <p>Reconnect electrical cable (WP 0053 00). If precleaner motor still does not operate, notify unit maintenance.</p>
<p>3. AIR HEATER DOES NOT HEAT FILTERED AIR.</p>	<p>1. Check to see if heater control knob is in OFF position. Turn heater control knob all the way to the right (WP 0053 00).</p>	<p>If heater still does not heat filtered air, notify unit maintenance.</p>

INITIAL SETUP:

Maintenance Level

Operator

TRACKS AND SUSPENSIONS

MALFUNCTION	TEST OR INSPECTION	CORRECTIVE ACTION
1. CARRIER PULLS TO ONE SIDE.	1. On crowned road or sloping ground.	Carrier will normally pull to one side of any slope.
	2. Check if track tension is equal on both sides.	Adjust track tension (T130 track) (WP 0058 00) or (T150 track) (WP 0058 01).
	3. Check if mud, dirt, or snow has built up on one track.	Clean tracks.
2. CARRIER THROWS TRACK.	1. Check if track is loose or worn.	Adjust track tension (T130 track) (WP 0058 00) or (T150 track) (WP 0058 01).
	2. Bad driving habits.	Do not use pivot steer when carrier is moving. Avoid sharp turns at high speed or on soft ground.
	3. Check if dirt, mud, or other material has built up in the track.	Keep the track clear. If you have to run through mud or snow, have unit maintenance remove track shrouds. On soft ground or in heavy brush, turn in a series of short turns so the track can clear itself.
3. TOO MUCH NOISE IN THE TRACK OR SUSPENSION.	1. Check if wrong tension is on track.	Adjust track tension (T130 track) (WP 0058 00) or (T150 track) (WP 0058 01).
	2. Check if track shoes are badly worn.	If shoes are worn, replace defective track shoes (T130 track) (WP 0060 00) or (T150 track) (WP 0060 01) or notify unit maintenance.
	3. Check if track pads are loose, worn, or missing.	Tighten loose pads. If any pads are worn or missing, replace defective track pads (T130 track) (WP 0061 00) or notify unit maintenance (T150 track).
	4. Check if sprockets or cushions are worn (WP 0062 00).	If sprockets or cushions are worn, notify unit maintenance.

MALFUNCTION	TEST OR INSPECTION	CORRECTIVE ACTION
<p>4. CARRIER RIDES TOO HARD.</p>	<p style="text-align: center;">WARNING</p> <div style="text-align: center;">  </div> <p>Hot shock absorbers can burn you. Let shock absorbers cool before you start to work on them.</p> <ol style="list-style-type: none"> 1. Check if carrier has one or more faulty shock absorbers. 2. Check if carrier has any broken torsion bars (WP 0057 00)□ 	<p>Check shock absorbers for leaks (WP 0057 00). If shock absorbers □ leak, notify unit □ maintenance.</p> <p>Feel the shocks after running. Good shocks will be noticeably warmer than the hull. A cool shock is a faulty one. Notify unit maintenance.</p> <p>If carrier has broken torsion bar, notify unit maintenance.</p>

INITIAL SETUP:

Maintenance Level

Operator

TRANSFER GEARCASE (M548A1)

MALFUNCTION	TEST OR INSPECTION	CORRECTIVE ACTION
1. NO POWER THROUGH TRANSFER GEARCASE WHEN ENGINE IS RUNNING.	<p style="text-align: center;"><u>CAUTION</u></p> <p style="text-align: center;">Never move the engine disconnect handle while the engine is running.</p> 1. Check if engine disconnect is not engaged.	Engage engine disconnect (WP 0013 00).
2. TRANSFER GEARCASE RUNS HOT OR NOISY.	1. Check for low transfer gearcase oil level.	Add oil as needed (WP 0057 00).

INITIAL SETUP:

Maintenance Level

Operator

TRANSMISSION

MALFUNCTION	TEST OR INSPECTION	CORRECTIVE ACTION
<p>1. CARRIER DOES NOT MOVE IN ANY RANGE.</p>	<p style="text-align: center;"><u>CAUTION</u></p> <p>Never move the engine disconnect handle while the engine is running.</p> <ol style="list-style-type: none"> 1. Check if engine disconnect (M548A1) is engaged. 2. Check if transmission (M548A3) to final drive is disconnected. 3. Check for low transmission oil level. 4. Check for broken track. 	<p>Engage engine disconnect (WP 0013 00).</p> <p>Notify unit maintenance if disconnected.</p> <p>Add oil as needed (WP 0057 00).</p> <p>Repair track ((WP 0060 00) (T130) or (WP 0060 01) (T150).</p>
<p>2. TRANSMISSION OIL HI TEMP WARNING LIGHT COMES ON (M548A1).</p>	<p style="text-align: center;"><u>CAUTION</u></p> <p>Do not operate carrier if TRANSMISSION OIL HI TEMP/TRANS OIL LOW PRESS is on. This light warns of possible low transmission oil. Transmission may be damaged.</p> <ol style="list-style-type: none"> 1. Check for bad driving habits. 2. Check for low transmission oil level. 	<p>Do not drive with RANGE SELECTOR lever in 1 range any longer than necessary.</p> <p>Add oil as needed (WP 0057 00).</p>

MALFUNCTION	TEST OR INSPECTION	CORRECTIVE ACTION
<p>3. TRANSMISSION LOW OIL PRESSURE WARNING LIGHT COMES ON (M548A3).</p>	<p style="text-align: center;"><u>CAUTION</u></p> <p>Operating vehicle with TRANSMISSION LOW OIL PRESSURE warning light on can damage transmission and may result in unpredictable vehicle operation. DO NOT OPERATE vehicle with TRANSMISSION LOW OIL PRESSURE warning light on.</p> <ol style="list-style-type: none"> 1. Reduce throttle to idle and stop vehicle on level ground. With transmission oil at operating temperature (engine coolant temperature gauge at 200°F (98°C)), set shift control to neutral and release brakes. 2. Check TRANSMISSION OIL CLOGGED FILTER light. 3. Check transmission oil level. 4. Increase engine speed to 1200 to 1300 rpm. 5. Check light. 	<p>If TRANSMISSION OIL CLOGGED FILTER light is lit, shut down engine and notify unit maintenance.</p> <p>If TRANSMISSION OIL CLOGGED FILTER light is not lit, go to Step 3 page 0056 00-27.</p> <p>If transmission oil level is low, add oil as needed (WP 0057 00). Go to Step 5 page 0056 00-27.</p> <p>If transmission oil level is not low, go to Step 4 page 0056 00-27.</p> <p>If TRANSMISSION LOW OIL PRESSURE light goes off, continue normal operation.</p> <p>If TRANSMISSION LOW OIL PRESSURE light stays lit, or lights again, shut down engine and notify unit maintenance.</p>

INITIAL SETUP:

Maintenance Level

Operator

TURN SIGNAL KIT

MALFUNCTION	TEST OR INSPECTION	CORRECTIVE ACTION
1. LIGHTS DON'T FLASH WITH CONTROL LEVER IN OPERATING POSITION.	1. Check if MASTER SWITCH is OFF. 2. Check if the driving light switch is in STOP or SER DRIVE position.	Turn MASTER SWITCH ON. Put the switch in STOP or SER DRIVE position (WP 0032 00).

INITIAL SETUP:

Maintenance Level

Operator

VEHICLE COMPARTMENT HEATER KIT

NOTE

A vehicle compartment heater kit is optional in the M548A1 carriers. M548A3 carriers have a vehicle compartment heater installed.

MALFUNCTION	TEST OR INSPECTION	CORRECTIVE ACTION
1. HEATER DOES NOT START WITH THE RUN-OFF-START SWITCH HELD IN START POSITION.	1. Check if MASTER SWITCH is OFF. 2. Defective heater.	Turn MASTER SWITCH ON. Notify unit maintenance.
2. HEATER OVERHEATS AND STOPS.	1. Check if the heater air intake, exhaust pipe or warm air outlet is blocked.	Find and remove whatever is blocking the heater system.
3. HEATER OVERHEATS AND DOESN'T STOP.	1. The heater is no good.	Turn the heater OFF and don't use it until unit maintenance fixes it.
4. HEATER DOES NOT PUT OUT ENOUGH HEAT.	1. Check if HI-LO switch is in LO position.	Move HI-LO switch to HI position (WP 0031 00).

TROUBLESHOOTING TABLE — Continued

0056 00

INITIAL SETUP:

Maintenance Level

Operator

WINCH (M548A1)

MALFUNCTION	TEST OR INSPECTION	CORRECTIVE ACTION
1. WINCH DOESN'T WORK WITH POWER TAKEOFF ENGAGED.	1. Check if DRUM LOCK handle is engaged. 2. Check if WINCH CLUTCH handle is not engaged. 3. Check if shear pin is broken.	Disengage DRUM LOCK handle (WP 0030 00). Engage WINCH CLUTCH handle (WP 0030 00). If shear pin is broken, notify unit maintenance.
2. WINCH DRUM DOESN'T TURN WITH CLUTCH HANDLE DISENGAGED.	1. DRUM LOCK handle is engaged.	Disengage DRUM LOCK handle (WP 0030 00).

CHAPTER 4
OPERATOR MAINTENANCE INSTRUCTIONS
FOR MAINTENANCE

WORK PACKAGE INDEX

<u>Title</u>	<u>Sequence No.</u>
PREVENTIVE MAINTENANCE CHECKS AND SERVICES.....	0057 00
INSPECT/ADJUST T130 TRACK TENSION.....	0058 00
ADJUST T150 TRACK TENSION.....	0058 01
BREAK/JOIN T130 TRACK.....	0059 00
BREAK/JOIN T150 TRACK.....	0059 01
REMOVE/INSTALL T130 TRACK SHOE.....	0060 00
REMOVE/INSTALL T150 TRACK SHOE.....	0060 01
ASSEMBLE T130 TRACK SHOE SECTIONS OFF VEHICLE.....	0060 02
REMOVE/INSTALL T130 TRACK PAD.....	0061 00
TRACK SHOE WEAR LIMITS.....	0061 01
INSPECT T130 SPROCKET WEAR.....	0062 00
MAINTENANCE OF AIR CLEANER ELEMENT (M548A1).....	0063 00
REMOVE/INSTALL AIR CLEANER ELEMENT DOOR (M548A3).....	0064 00
CHECK/FILL COOLING SYSTEM (M548A1).....	0065 00
CHECK/FILL COOLING SYSTEM (M548A3).....	0066 00
CHECK DRIVE BELTS TENSION (M548A1).....	0067 00
CHECK DRIVE BELTS TENSION (M548A3).....	0068 00
DRAIN FUEL FILTERS AND AIR SEPARATOR TANK.....	0069 00
MAINTENANCE OF BATTERIES.....	0070 00
MAINTENANCE OF CARGO COVER.....	0071 00
MAINTENANCE OF CAB COVER AND WINDOWS.....	0072 00
SERVICE BILGE PUMP.....	0073 00
MAINTENANCE OF MACHINE GUN RING MOUNT ASSEMBLY (M66).....	0074 00
MAINTENANCE OF AIR BRAKE KIT (M548A1).....	0075 00
REMOVE/INSTALL HULL BOTTOM ACCESS COVER AND DRAIN COVER.....	0076 00
RAISE/LOWER CAB CENTER FLOOR PLATES.....	0077 00
REMOVE/INSTALL BULKHEAD PROTECTOR.....	0078 00

PREVENTIVE MAINTENANCE CHECKS AND SERVICES

0057 00

THIS WORK PACKAGE COVERS:

- Before (Table 16, page 0057 00-11).
- During (Table 17, page 0057 00-40).
- After (Table 18, page 0057 00-54).
- Weekly (Table 19, page 0057 00-95).

INITIAL SETUP:

Maintenance Level

Operator

Personnel Required

Driver

References

- DA PAM 738-750
- FM 9-207
- TM 9-1005-213-10
- TM 9-1005-224-10

Equipment Condition

Engine stopped (WP 0023 00 or WP 0024 00)

SCOPE

This section details Preventive Maintenance Checks and Services (PMCS) required for the M548A1 and M548A3 carriers. Your PMCS table has been provided so you can keep your equipment in good operating condition and ready for its primary mission.

MAINTENANCE FORMS AND RECORDS

Every mission begins and ends with paperwork. There isn't much of it, but you have to keep it up. The forms and records you fill out have many uses. They are a permanent record of the services, repairs, and changes made to your carrier. They are reports to unit maintenance and to your track commander. They are checklists that tell you whether those faults have been fixed. For information on forms and records, see DA PAM 738-750.

WARNINGS AND CAUTIONS

Before you begin operating your carrier, do the BEFORE (B) Preventive Maintenance Checks and Services (PMCS). Pay attention to all WARNINGS and CAUTIONS. A WARNING alerts you to danger. It means you or a crew member can be injured if the WARNING is not followed. A CAUTION means the carrier can become damaged if the CAUTION is not followed. It is very important to keep in mind all WARNINGS and CAUTIONS when you perform this PMCS.

EXPLANATION OF TABLE ENTRIES

Item Number Column — Numbers in this column are for reference. When completing DA Form 2404 (Equipment Inspection and Maintenance Worksheet), include the item number for the check/service indicating a fault. Item numbers also appear in the order that you must do checks and services for the intervals listed.

Interval Column — This column tells you when you must do the procedure in the *procedure* column.

BEFORE procedures must be performed prior to the equipment leaving its containment area or performing its mission.

DURING checks are performed by the track commander/gunner per the PMCS table to monitor and identify faults in equipment performance during the mission.

AFTER procedures are performed per the PMCS table at the conclusion of the mission to identify and correct faults which will preclude the next mission.

WEEKLY as well as BEFORE PMCS procedures must be performed if:

You are the assigned crewmember and have not operated the hull since the last WEEKLY.

You are operating the carrier for the first time.

When a check or service procedure is required for both WEEKLY and BEFORE intervals, it is not necessary to do the procedures twice.

Item To Be Checked or Serviced Column — This column lists the item to be checked or serviced.

Crewmember/Procedure Column — This column gives the procedure you must do to check or service the item listed in the Item To Be Checked or Serviced column to know if the equipment is ready or available for its intended mission or for operation. You must do the procedure at the time stated in the interval column. Carefully follow these instructions. If you do not have the tools, or if the procedure tells you to, have unit maintenance do the work.

Equipment Not Ready/Available If: Column — Information in this column tells you what faults will keep your equipment from being capable of performing its primary mission. If you make check and service procedures that show faults listed in this column, do not operate the equipment. Follow standard operating procedures for maintaining the equipment or reporting equipment failure.

If you find something wrong when performing PMCS, fix it if you can by using Troubleshooting Procedures (WP 0054 00) or maintenance procedures. Notify unit maintenance if you can't fix it.

INSPECTION

Take along the tools you need to make all the checks. You ALWAYS need a wiping rag (WP 0083 00, Item 16) or two and an adjustable wrench (WP 0081 00, Item 43) to tighten loose fittings.

When you inspect for GOOD CONDITION, you look at the item to see that it is safe and serviceable.

When you inspect for CORRECT ASSEMBLY AND STOWAGE, you look at the item to see if it is present and installed correctly and securely.

There are some items that need to be checked that are common to all parts of the carrier. Keep your wrench and rag handy and check these items each time you do your BEFORE preventive maintenance.

KEEP IT CLEAN

Dirt, grease, oil, and debris only get in the way and may cover up a serious problem. While doing your PMCS, clean as you work and as needed. Use cleaning compound on all metal surfaces. Use soap and water when you clean rubber or plastic material.

BOLTS, NUTS, AND SCREWS

Check them all for obvious looseness, missing, bent, or broken condition. You can't try them all with a tool, but you can look for chipped paint, bare metal, or rust around bolt heads. If you find one you think is loose, tighten it. If you cannot tighten it, report it to unit maintenance.

WELDS

Look for loose or chipped paint, rust, or gaps where parts are welded together. If you find a bad weld, report it to unit maintenance.

ELECTRONIC WIRING AND CONNECTIONS

Look for cracked or broken wires, bare wires, and loose or broken connectors. Tighten loose connectors and make sure the wires are in good shape. If cracked or broken wires, bare wires, and/or broken connectors are found, report it to unit maintenance.

HOSES AND FLUID LINES

While doing your PMCS, look for wear, damage, and leaks in all hoses and fluid lines. Make sure clamps and fittings are tight. Wet spots mean leaks. A stain around a fitting or connector can mean a leak. Look for these telltale signs. If a leak comes from a loose fitting or connector, tighten it. If a hose or line appears broken or worn out, report it to unit maintenance.

MOUNTED ACCESSORIES

Inspect that mounted accessories are secure and in place before you begin to operate your carrier.

FLUID LEAKS

CAUTION

Class III leaks may cause equipment to become damaged. Do not operate equipment with Class III leaks. Report Class III leaks to your supervisor or to unit maintenance as soon as possible.

NOTE

You are allowed to operate equipment with minor leaks (Class I or II). How much fluid each item or system being checked or inspected can hold must be considered. When in doubt, notify unit maintenance. When operating equipment with Class I or II leaks, continue to check fluid levels as required in your PMCS. Report Class III leaks to unit maintenance for corrective action right away.

Any fuel leak will make the carrier NOT READY/AVAILABLE.

You need to know how fluid leaks affect your carrier. The following are definitions of the types or “classes” of leaks. You must know them to determine the status of your carrier. Learn them. Become familiar with each kind of leak and what each look like. Remember, when in doubt, NOTIFY UNIT MAINTENANCE!

CLASS I	Seepage of fluid (as indicated by wetness or discoloration) not great enough to form drops.
CLASS II	Leakage of fluid great enough to form drops, but not enough to cause drops to drip from item being checked/inspected.
CLASS III	Leakage of fluid great enough to form drops that fall from the item being checked/inspected.

LUBRICATION INTERVALS

Service Intervals — Normal Conditions

For safer, more trouble-free operation, see to it that your carrier is serviced when it needs it.

Service Intervals — Unusual Conditions

Your carrier will often need extra service and care when you operate under unusual conditions. High or low temperatures, long periods of hard use, continued use in sand, water, mud, or snow, will break down the lubricant. Then you have to add or change lubricant more often. But during periods when the carrier is not used, the service intervals can be stretched out.

ARMY OIL ANALYSIS PROGRAM (AOAP)

NOTE

Park carrier on level ground to check oil levels. Clean fittings with cleaning compound. Dry before lubricating. Check/lubricate all oil and grease fitting points after washing or fording.

AOAP is an effective maintenance diagnostic tool and not a maintenance substitute. TB 43-106 must not be interpreted to mean that AOAP minimizes in any way the need to employ good maintenance practices and strong maintenance discipline.

SAMPLING REQUIREMENTS

Samples may be taken without warming a component to operating temperature if the equipment has been operated within the last 30 days. If the equipment has not been operated within the last 30 days, these requisites apply to both routine and special sampling. Several hours of operation are needed to completely mix old and new oils.

SAMPLING PROCEDURES

Perform AFTER operation checks and services.

NOTE

DO NOT ADD OIL immediately prior to taking oil samples. When AFTER operation checks and services indicate the need to replenish oil levels, WAIT until after taking samples. New oil added immediately prior to taking samples will adversely effect oil analysis results.

Obtain two sample bottles (NSN 8125-01-082-9697) and two DA Form 2026 from the unit AOAP monitor.

Start engine (WP 0013 00 or WP 0014 00). If required (see SAMPLING REQUIREMENTS above), drive carrier (WP 0020 00 or WP 0021 00) to bring engine and transmission up to normal operating temperatures.

Stop carrier and set the brakes (WP 0012 00).

Place range selector in the N (Neutral) position and keep engine running. On M548A3, lock the steering wheel (WP 0004 00).

Raise crew seat and center floor plate (WP 0077 00).

With engine operating, remove dust caps from the engine and transmission oil sampling valves (WP 0002 00).

Open sample valve on engine oil filter and drain a small amount of oil into a container to clear valve of grit and contamination. (Properly dispose of container and oil upon completion of sample taking.) Fill sampling bottle to the neck shoulder and seal it. Attach DA Form 2026 to sampling bottle.

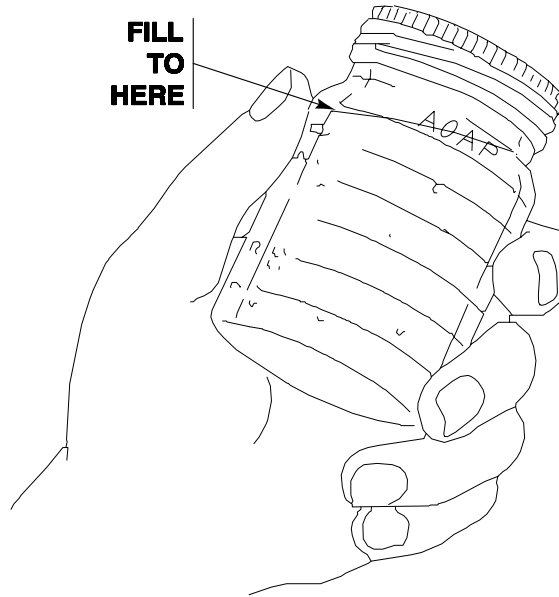

Close oil sample valve and install dust cap.

Take oil sample from transmission in the same manner (see previous three steps).

Stop engine (WP 0023 00 or WP 0024 00).

Lower crew seat and center floor plate (WP 0077 00).

Deliver sample bottles to the unit AOAP monitor.

NOTE

For location of nearest AOAP Laboratory and complete information about AOAP, refer to TB 43-0106. “Oil filters shall be serviced/cleaned/changed as applicable, when: (a) They are known to be contaminated, or clogged; (b) Service is recommended by AOAP Laboratory analysis, or (c) At prescribed hard time intervals.”

PRESERVATION OIL

If engine/transmission has been filled with preservation oil, leave this oil in engine/transmission until first scheduled oil change. Maintain operating oil level by adding applicable grade oil (OE/HDO or OEA). When first scheduled oil change is due, notify unit maintenance to refill engine/transmission with applicable grade of oil. See Lubrication Tables below.

LUBRICATION TABLES

Lubrication intervals will be indicated by one of the following symbols:

- OC = AOAP On-Condition
- B = Before
- D = Daily
- AF = After
- W = Weekly
- M = Monthly
- S = 1,500 miles (2,400 km), Semi-annually
- AN = Annually

The following tables are used during PMCS lubrication checks.

Table 1. LUBRICATION SYMBOLS

SYMBOL	NOMENCLATURE	SPECIFICATION
FRH	Hydraulic Fluid, Rust Inhibited, Fire Resistant	MIL-PRF-46170C
GAA	Grease, Automotive and Artillery	MIL-PRF-10924G
OE/HDO	Lubricating Oil, Internal Combustion Engine	MIL-PRF-2104G
OEA	Lubricating Oil, Internal Combustion Engine	MIL-PRF-46167C
PE	Preservation Oil	MIL-PRF-21260E
GIA	Grease, Aircraft and Instrument	MIL-G-23827B

Table 2. LUBRICANT USAGE: ENGINE (M548A1)

COMPONENTS INTERVALS = AF, OC	REFILL CAPACITY (APPROX)	LUBRICANTS TO USE AT EXPECTED TEMPERATURES *	
		+5°F to +120°F (-15°C to +48.8°C)	+40°F to -60°F (+5°C to -51.1°C)
OE/HDO (MIL- PRF-2104G) or OEA (MIL-PRF-46167C)	18 qt.	OE/HDO-15/40	OEA
PE (MIL-PRF-21260E)		PE 30-1	
* For Arctic Operation Refer to FM 9-207			

Table 3. LUBRICANT USAGE: ENGINE (M548A3)

COMPONENTS INTERVALS = D, S, OC	REFILL CAPACITY (APPROX)	LUBRICANTS TO USE AT EXPECTED TEMPERATURES *		
		Above +32°F (Above 0°C)	+40°F to -10°F (+5°C to -23°C)	0°F to -65°F (-18°C to -54°C)
OE/HDO (MIL- PRF-2104G) or OEA (MIL-PRF-46167C)	18 qt.	OE/HDO-15/40	OE/HDO-15/40	OEA
* For Arctic Operation Refer to FM 9-207				

Table 4. LUBRICANT USAGE: TRANSMISSION (M548A3)

COMPONENTS INTERVALS = AF, S, AN, OC	REFILL CAPACITY (APPROX)	LUBRICANTS TO USE AT EXPECTED TEMPERATURES *	
		+5°F to +120°F (-15°C to +48.8°C)	+40°F to -60°F (+5°C to -51.1°C)
OE/HDO (MIL-PRF-2104G) or OEA (MIL-PRF-46167C)	40 qt. or 10 gal.	OE/HDO-15/40	OEA
PE (MIL-PRF-21260E)	See Note	PE 30-1	
NOTE: If transmission has been filled with preservation oil (MIL-PRF-21260E) by the manufacturer or at time of overhaul, leave this oil in transmission until first scheduled oil change. Maintain operating oil level by adding same grade of PE oil. When first scheduled oil change is made, refill transmission with applicable grade oil (OE/HDO or OEA).			
* For Arctic Operation Refer to FM 9-207			

Table 5. LUBRICANT USAGE: TRANSMISSION (M548A1)

COMPONENTS INTERVALS = AF, S, OC	REFILL CAPACITY (APPROX)	LUBRICANTS TO USE AT EXPECTED TEMPERATURES *		
		Above +32°F (Above 0°C)	+40°F to -10°F (+5°C to -23°C)	0°F to -65°F (-18°C to -54°C)
OE/HDO (MIL-PRF-2104G) or OEA (MIL-PRF-46167C)	16 qt.	OE/HDO-15/40	OE/HDO-15/40	OEA
* For Arctic Operation Refer to FM 9-207				

Table 6. LUBRICANT USAGE: TRANSFER GEARCASE

COMPONENTS INTERVALS = AF, S, OC	REFILL CAPACITY (APPROX)	LUBRICANTS TO USE AT EXPECTED TEMPERATURES *		
		Above +32°F (Above 0°C)	+40°F to -10°F (+5°C to -23°C)	0°F to -65°F (-18°C to -54°C)
OE/HDO (MIL-PRF-2104G) or OEA (MIL-PRF-46167C)	2.5 qt.	OE/HDO-15/40	OE/HDO-15/40	OEA
* For Arctic Operation Refer to FM 9-207				

Table 7. LUBRICANT USAGE: DIFFERENTIAL

COMPONENTS INTERVALS = AF, S, OC	REFILL CAPACITY (APPROX)	LUBRICANTS TO USE AT EXPECTED TEMPERATURES *		
		Above +32°F (Above 0°C)	+40°F to -10°F (+5°C to -23°C)	0°F to -65°F (-18°C to -54°C)
OE/HDO (MIL- PRF-2104G) or OEA (MIL-PRF-46167C)	20 qt.	OE/HDO-15/40	OE/HDO-15/40	OEA
* For Arctic Operation Refer to FM 9-207				

Table 8. LUBRICANT USAGE: FINAL DRIVES

COMPONENTS INTERVALS = D, S, OC	REFILL CAPACITY (APPROX)	LUBRICANTS TO USE AT EXPECTED TEMPERATURES *		
		Above +32°F (Above 0°C)	+40°F to -10°F (+5°C to -23°C)	0°F to -65°F (-18°C to -54°C)
OE/HDO (MIL- PRF-2104G) or OEA (MIL-PRF-46167C)	3.5 qt. or 7 pt.	OE/HDO-15/40	OE/HDO-15/40	OEA
* For Arctic Operation Refer to FM 9-207				

Table 9. LUBRICANT USAGE: TACHOMETER AND SPEEDOMETER

COMPONENTS INTERVALS = AN, S	REFILL CAPACITY (APPROX)	LUBRICANTS TO USE AT EXPECTED TEMPERATURES *	
		+5°F to +120°F (-15°C to +48.8°C)	+40°F to -60°F (+5°C to -51.1°C)
GIA (MIL-G-23827B)	As Required	All Temperatures	
GAA (MIL-PRF- 10924G)	As Required		
OE/HDO (MIL- PRF-2104G) or OEA (MIL-PRF-46167C)	As Required		
* For Arctic Operation Refer to FM 9-207			

Table 10. LUBRICANT USAGE: FAN GEAR BOX

COMPONENTS INTERVALS= M, S	REFILL CAPACITY (APPROX)	LUBRICANTS TO USE AT EXPECTED TEMPERATURES *	
		+5°F to +120°F (-15°C to +48.8°C)	+40°F to -60°F (+5°C to -51.1°C)
OE/HDO (MIL-PRF-2104G)	0.75 pt.	OE/HDO-15/40	OEA
* For Arctic Operation Refer to FM 9-207			

Table 11. LUBRICANT USAGE: PULLEY SUPPORT ARM

COMPONENTS INTERVALS = M, S	REFILL CAPACITY (APPROX)	LUBRICANTS TO USE AT EXPECTED TEMPERATURES *	
		+5°F to +120°F (-15°C to +48.8°C)	+40°F to -60°F (+5°C to -51.1°C)
GAA (MIL-PRF-10924G)	As Required	All Temperatures	
* For Arctic Operation Refer to FM 9-207			

Table 12. LUBRICANT USAGE: STEERING CONTROL BEARINGS; FOOT BRAKE PEDAL LINKAGE

COMPONENTS INTERVALS = S	REFILL CAPACITY (APPROX)	LUBRICANTS TO USE AT EXPECTED TEMPERATURES *	
		+5°F to +120°F (-15°C to +48.8°C)	+40°F to -60°F (+5°C to -51.1°C)
GAA (MIL-PRF-10924G)	As Required	All Temperatures	
* For Arctic Operation Refer to FM 9-207			

Table 13. LUBRICANT USAGE: PIVOT STEER SYSTEM

COMPONENTS INTERVALS = S	REFILL CAPACITY (APPROX)	LUBRICANTS TO USE AT EXPECTED TEMPERATURES *		
		Above +32°F (Above 0°C)	+40°F to -10°F (+5°C to -23°C)	0°F to -65°F (-18°C to -54°C)
FRH (MIL-PRF-46170C)	1 pt.	All Temperatures		
* For Arctic Operation Refer to FM 9-207				



Table 14. LUBRICANT USAGE: FAN DRIVE SHAFT; STEERING CONTROL LEVER

COMPONENTS INTERVALS = S	REFILL CAPACITY (APPROX)	LUBRICANTS TO USE AT EXPECTED TEMPERATURES *		
		Above +32°F (Above 0°C)	+40°F to -10°F (+5°C to -23°C)	0°F to -65°F (-18°C to -54°C)
GAA (MIL-PRF-10924G)	As Required	All Temperatures		
* For Arctic Operation Refer to FM 9-207				

Table 15. LUBRICANT USAGE: UNIVERSAL JOINT

COMPONENTS INTERVALS= S	REFILL CAPACITY (APPROX)	LUBRICANTS TO USE AT EXPECTED TEMPERATURES *	
		+5°F to +120°F (-15°C to +48.8°C)	+40°F to -60°F (+5°C to -51.1°C)
GAA (MIL-PRF-10924G)	As Required	All Temperatures	
* For Arctic Operation Refer to FM 9-207			

Table 16. Preventive Maintenance Checks and Services for M548A1/M548A3, Before

ITEM NO.	INTERVAL	MAN-HOUR	ITEM TO BE CHECKED OR SERVICED	CREWMEMBER PROCEDURE	EQUIPMENT NOT READY/ AVAILABLE IF:
			M548A1	<p style="text-align: center;">WARNING</p>  <p>Failure to lock differential steering levers and block roadwheels may allow carrier to move. This could result in personnel injury or death. Always lock differential steering levers and block roadwheels before performing PMCS.</p>	
			M548A3	<p style="text-align: center;">WARNING</p>  <p>Failure to set parking brake and block wheels can allow carrier to move and could result in personnel injury or death. Always set parking brake and block wheels before performing PMCS.</p> <p style="text-align: center;">NOTE</p> <p>Perform your WEEKLY as well as BEFORE PMCS if: You are the assigned operator but have not operated the carrier since your last weekly inspection or you are operating the carrier for the first time.</p>	

PREVENTIVE MAINTENANCE CHECKS AND SERVICES — Continued

0057 00

ITEM NO.	INTERVAL	MAN-HOUR	ITEM TO BE CHECKED OR SERVICED	CREWMEMBER PROCEDURE	EQUIPMENT NOT READY/ AVAILABLE IF:
1	Before		Vehicle Exterior (Ground)	<p>THINK SAFETY. Inspect and work safely. Protect yourself and your crew members. Read and observe all warnings.</p> <p>DRIVER</p> <p>a. Inspect for damage or missing items. Inspect body, tracks, roadwheels, and lighting fixtures. Make sure all accessory items (water cans, spare track shoes, shovel) are properly secured to the carrier. Replace missing items. Secure accessories. Report damaged items after operation. Inspect damaged or missing hooks, pins, or clips on towing eyes.</p>	
<p>The diagram shows a side view of a tracked carrier. Four labels with arrows point to specific parts: 'LIGHTING FIXTURES' points to the front of the vehicle; 'TOWING EYES' points to the front bumper area; 'TRACKS' points to the continuous track system; and 'ROAD WHEELS' points to the large wheels supporting the tracks.</p>					
2	Before		Exterior Leaks	<p>DRIVER</p> <p>a. Inspect beneath carrier for leakage of lubricant, fuel, coolant, or hydraulic fluid. Inspect roadwheel hubs for leaks.</p> <p>b. Inspect external carrier body for signs of leakage and damage.</p>	<p>Any fuel leak or Class III leak evident.</p> <p>Any obvious damage that will prevent operation.</p>

PREVENTIVE MAINTENANCE CHECKS AND SERVICES — Continued

0057 00

ITEM NO.	INTERVAL	MAN-HOUR	ITEM TO BE CHECKED OR SERVICED	CREWMEMBER PROCEDURE	EQUIPMENT NOT READY/ AVAILABLE IF:
3	Before		Exterior Pull Handle (Fixed Fire Extinguisher)	<p>c. Check hull access and drain plugs (five plugs, M548A1; four plugs, M548A3). Make sure they are in place.</p> <p>d. Report Class I and II leaks after operation. Maintain fluid levels.</p> <p>DRIVER</p> <p>a. Visually inspect seal and locking wire on exterior pull handle.</p> <p>b. Make sure the seal or locking wire is not broken.</p> <div data-bbox="846 993 1279 1234" style="text-align: center;"> <p>The diagram shows a cross-section of a circular pull handle. A label 'SEAL' points to a ring-like component inside the handle. Another label 'PULL HANDLE' points to the central protruding part of the handle.</p> </div>	<p>Any plugs missing.</p> <p>Seal or locking wire missing or broken.</p>
4	Before		Exterior	<p>DRIVER</p> <p>a. Make a quick inspection for obvious missing or damaged items.</p> <p>b. Rear power plant access covers and grille are present and in place.</p> <p>c. Cargo/ammunition is properly stowed and secured for travel.</p>	<p>Any access cover missing.</p>

ITEM NO.	INTERVAL	MAN-HOUR	ITEM TO BE CHECKED OR SERVICED	CREWMEMBER PROCEDURE	EQUIPMENT NOT READY/ AVAILABLE IF:
5	Before		Coolant and System Radiator Cap (M548A1)	<p>DRIVER</p> <p style="text-align: center;">WARNING</p> <div data-bbox="889 688 1052 856" style="text-align: center;"> </div> <p>Coolant level check is normally accomplished before operation, when vehicle is cold. However, if vehicle has been running, cap may be very hot. Do not remove a hot cap with your bare hand. Watch for high pressure when taking off a hot cap.</p> <ol style="list-style-type: none"> a. Check filler cap visually for obvious damage and fit. b. Remove and inspect cap. <div data-bbox="516 1289 1062 1764" style="text-align: center;"> </div>	Cap or gasket missing or unserviceable.

PREVENTIVE MAINTENANCE CHECKS AND SERVICES — Continued

0057 00

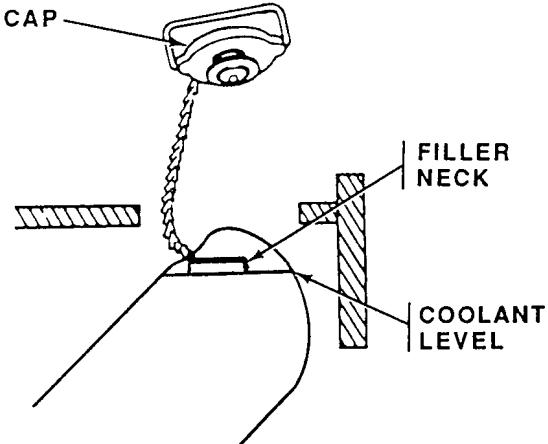
ITEM NO.	INTERVAL	MAN-HOUR	ITEM TO BE CHECKED OR SERVICED	CREWMEMBER PROCEDURE	EQUIPMENT NOT READY/ AVAILABLE IF:
				<p>c. Check to make sure coolant reaches the bottom of filler neck.</p> <p>d. Check coolant level on filler neck.</p> <p>e. Add coolant as necessary.</p> <p>f. If you find coolant level way below filler neck, inspect radiator, hoses and lines for leaks.</p> 	<p>Cooling system Class III leaks.</p>

ITEM NO.	INTERVAL	MAN-HOUR	ITEM TO BE CHECKED OR SERVICED	CREWMEMBER PROCEDURE	EQUIPMENT NOT READY/ AVAILABLE IF:
6	Before		Coolant Level (M548A3)	<p>CREWMEMBER</p> <p style="text-align: center;">WARNING</p>  <p>Hot coolant can burn you. Do not touch hot cap with your bare hand. Let engine cool before removing filler cap.</p> <ol style="list-style-type: none"> a. Check coolant level as follows: b. Remove coolant fill cap. c. Check that coolant level reaches bottom of filler neck. d. Add coolant as needed. e. If coolant level is way below bottom of filler neck, check indicator and coolant lines for leaks. f. Check that coolant fill cap is in good shape and seals tightly in place. g. For coolant system maintenance, see WP006600. 	Coolant fill cap missing. Any sign of Class III leak.

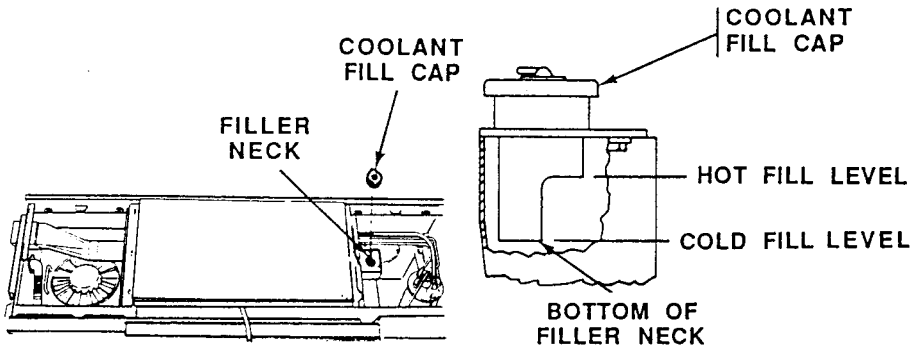

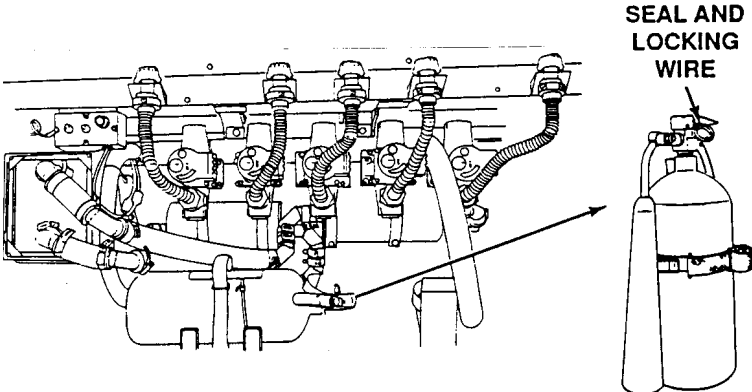
ITEM NO.	INTERVAL	MAN-HOUR	ITEM TO BE CHECKED OR SERVICED	CREWMEMBER PROCEDURE	EQUIPMENT NOT READY/ AVAILABLE IF:
7	Before		Fire Extinguishers (Portable)	<p>DRIVER</p> <p style="text-align: center;">WARNING</p>  <p>Carrier fire could cause injury or death and destroy equipment. Do not operate carrier unless both fire extinguishers are ready to use.</p> <ol style="list-style-type: none"> a. Check fire extinguishers as follows: b. Check portable fire extinguisher control seal. c. Make sure seal or locking wire is not broken. d. Report broken seal or locking wire to unit maintenance. e. Inspect fire extinguisher for security of mounting hardware and missing hardware. 	<p>Extinguisher missing.</p> <p>Seal or locking wire missing or broken.</p>
 <p>M548A3 SHOWN</p>					

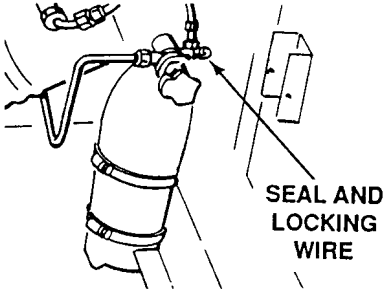
ITEM NO.	INTERVAL	MAN-HOUR	ITEM TO BE CHECKED OR SERVICED	CREWMEMBER PROCEDURE	EQUIPMENT NOT READY/ AVAILABLE IF:
8	Before		Fire Extinguishers (Fixed)	<p>DRIVER</p> <p style="text-align: center;">WARNING</p> <div style="text-align: center;">  </div> <p>Carrier fire could cause injury or death and destroy equipment. Except in an emergency, do not operate the vehicle if either fire extinguisher has been discharged or will not work.</p> <ol style="list-style-type: none"> a. Check fixed fire extinguisher control seal (located behind left side of driver's seat) as follows: b. Make sure seal or locking wire is not broken or missing from TURN handle or PULL handle. c. Inspect fixed fire extinguisher for security of mounting and missing hardware. d. Report broken or missing seal, locking wire, or missing hardware to unit maintenance. <div style="text-align: center;">  <p>SEAL AND LOCKING WIRE</p> </div>	Extinguisher missing. Seal or locking wire missing or broken.

ITEM NO.	INTERVAL	MAN-HOUR	ITEM TO BE CHECKED OR SERVICED	CREWMEMBER PROCEDURE	EQUIPMENT NOT READY/ AVAILABLE IF:
9	Before		Airbox Heater — Below 40°F (4.44°C)	<p>DRIVER</p> <ol style="list-style-type: none"> Check the airbox heater as follows: Turn the master switch on and pull the fuel shut-off. <p style="text-align: center;">NOTE</p> <p>Be sure the starter is engaged before operating heater.</p> <ol style="list-style-type: none"> Press the starter switch. Turn the airbox heater on. Look for puffs of black smoke from the engine exhaust. If you see smoke, heater is OK. Notify unit maintenance if no smoke appears. 	

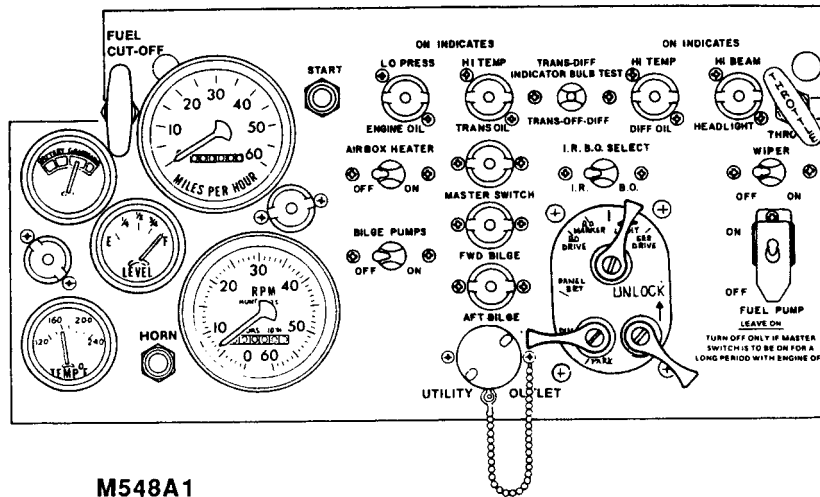

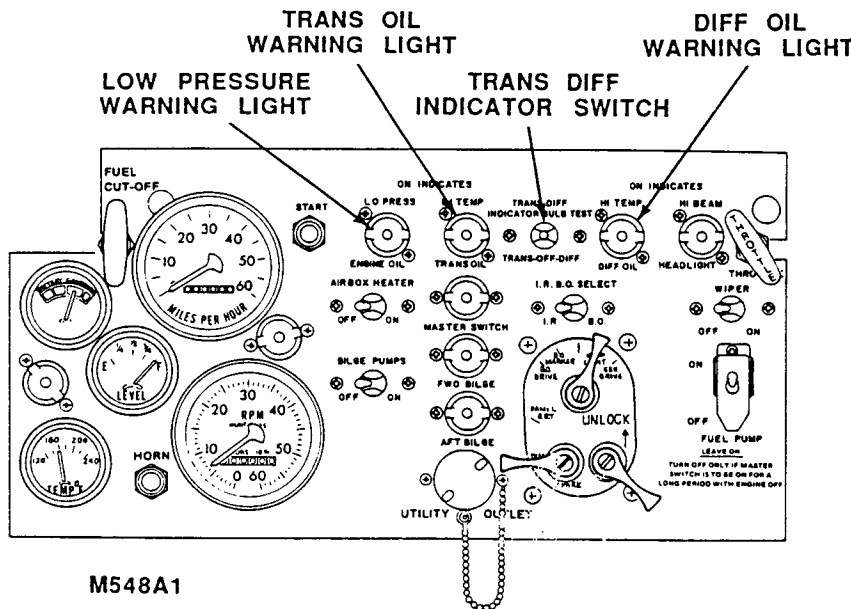

M548A1

ITEM NO.	INTERVAL	MAN-HOUR	ITEM TO BE CHECKED OR SERVICED	CREWMEMBER PROCEDURE	EQUIPMENT NOT READY/ AVAILABLE IF:
10	Before		Instrument Panel Warning Lights	<p>DRIVER</p> <ol style="list-style-type: none"> Before you start the engine, check your instrument panel warning lights as follows: Make sure Master Switch is ON. Check that engine LOW PRESSURE warning lights come on. For M548A1, flip TRANS-DIFF indicator bulb test switch to the right and left. TRANS OIL warning light and DIFF OIL warning light must come on. 	<p>LOW PRESSURE warning light fails to come on.</p> <p>TRANS-DIFF warning light fails to come on.</p>



PREVENTIVE MAINTENANCE CHECKS AND SERVICES — Continued

0057 00

ITEM NO.	INTERVAL	MAN-HOUR	ITEM TO BE CHECKED OR SERVICED	CREWMEMBER PROCEDURE	EQUIPMENT NOT READY/ AVAILABLE IF:
11	Before		Instrument Panel Temperature, Fuel Level, and Tachometer Gauges	<p>DRIVER</p> <p style="text-align: center;">WARNING</p>  <p>Carbon monoxide gas is a deadly poison. Make sure the power plant access panels, cab floor panels and seat support are closed tight before you start the engine.</p> <p style="text-align: center;">WARNING</p>  <p>Ear protection must be worn when operating this carrier.</p>	

ITEM NO.	INTERVAL	MAN-HOUR	ITEM TO BE CHECKED OR SERVICED	CREWMEMBER PROCEDURE	EQUIPMENT NOT READY/ AVAILABLE IF:
				<p style="text-align: center;">WARNING</p> <div style="text-align: center;">  </div> <p>Personnel could be killed if ammunition or other cargo gets into engine compartment. Do not operate vehicle carrying cargo without rear engine access panels and/or plywood protector installed.</p> <ol style="list-style-type: none"> a. <input type="checkbox"/> Check instrument panel gauges. b. Start engine in neutral position. Set hand throttle to run engine at 800 to 1000 rpm for 3-5 minutes to warm up engine. Release hand throttle. c. Check that fuel gauge is operating. d. Check tachometer for proper operation and that normal idle speed is 650 to 700 rpm. <p style="text-align: center;">NOTE</p> <p>Report abnormal idle speed to unit maintenance. Turn off engine if temperature goes above 220°F (104.4°C).</p> <ol style="list-style-type: none"> e. Check temperature gauge for proper operation and that normal coolant temperature is 160 to 220°F (17.1 to 104.4°C). 	<p>Engine fails to start in neutral (M548A1) or SL (M548A3).</p> <p>Temperature gauge is not working or missing.</p>

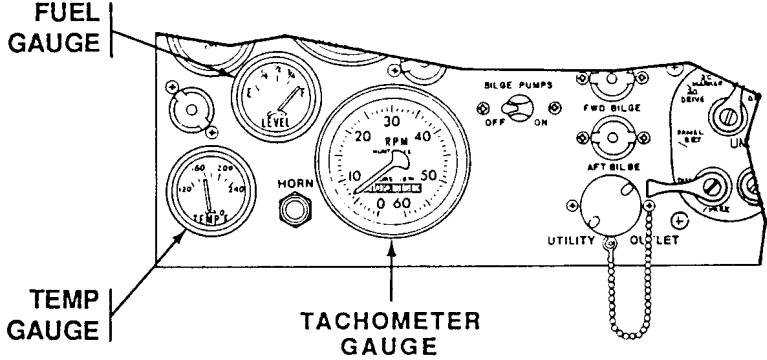
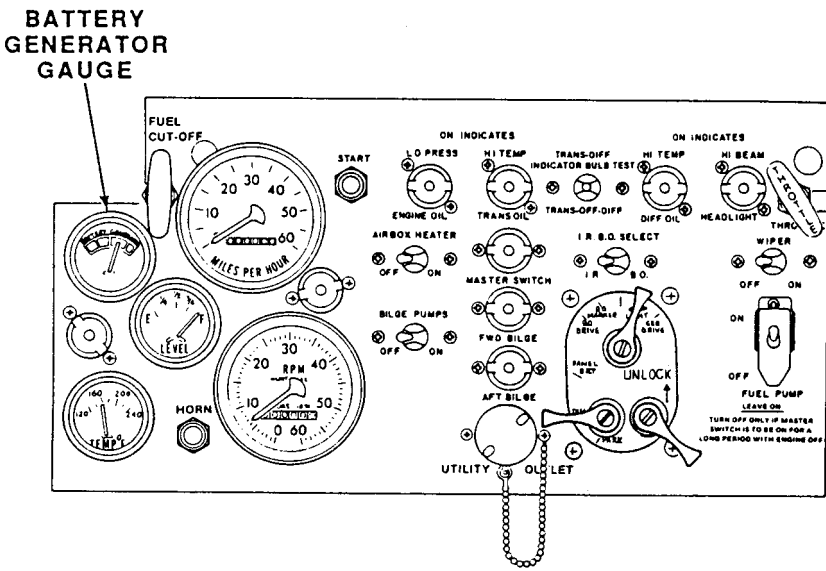
ITEM NO.	INTERVAL	MAN-HOUR	ITEM TO BE CHECKED OR SERVICED	CREWMEMBER PROCEDURE	EQUIPMENT NOT READY/ AVAILABLE IF:
				<p>f. Check the battery-generator. Gauge should read in the green zone.</p>	<p>Gauge is not in the green zone.</p>
				<p>M548A1</p>	

PREVENTIVE MAINTENANCE CHECKS AND SERVICES — Continued

0057 00

ITEM NO.	INTERVAL	MAN-HOUR	ITEM TO BE CHECKED OR SERVICED	CREWMEMBER PROCEDURE	EQUIPMENT NOT READY/ AVAILABLE IF:
12	Before		Steering and Braking Controls (M548A1)	<p>DRIVER</p> <ol style="list-style-type: none"> a. Inspect for proper installation of steering lever assemblies. b. Check that mounting bracket screws are tight. c. Check that quadrants are securely mounted and screws and nuts are tight. d. Inspect for proper operation of steering levers. e. Unlock levers. Push down on lock buttons and pull both steering levers rearward. If they are properly adjusted, resistance will be felt in both levers between the 2nd and 3rd notches of the quadrants. f. Unlock levers. Pull back and release levers several times. Get to know the feel of your carrier's steering levers. g. If your carrier's steering levers do not feel right to you, notify unit maintenance. 	<p>Any screws or nuts are loose or missing.</p> <p>Quadrants loose or missing.</p> <p>If resistance is felt at the first notch of quadrants. If resistance is not felt until levers are at the fourth notch of quadrants.</p> <p>If the difference between the left and right lever is greater than one notch.</p>

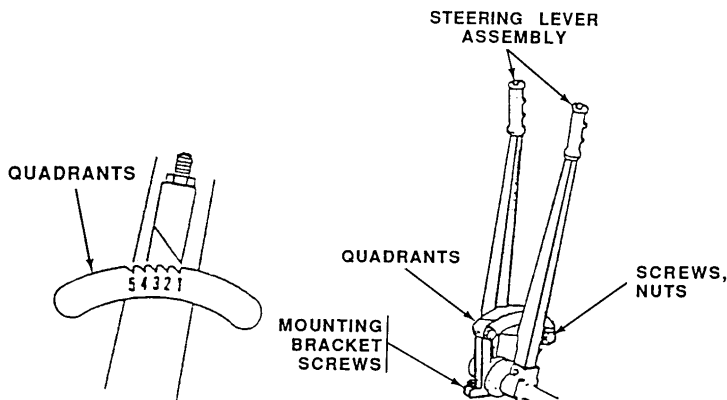

ITEM NO.	INTERVAL	MAN-HOUR	ITEM TO BE CHECKED OR SERVICED	CREWMEMBER PROCEDURE	EQUIPMENT NOT READY/ AVAILABLE IF:
13	Before		Track Tension	<p>DRIVER</p> <p style="text-align: center;">WARNING</p> <div style="text-align: center;">  </div> <p>Not having the correct track tension during inspection can cause you to not see defective track parts that could cause track failure and loss of vehicle control. Soldiers can be killed or injured.</p> <p>Adjust track tension before inspecting track assembly and track shoes.</p> <p style="text-align: center;">NOTE</p> <p>Perform adjustment after vehicle is fully loaded for each mission. Readjust track tension after unloading vehicle.</p> <p style="text-align: center;">NOTE</p> <p>Drive carrier onto hard level ground. Shift range selector to SL (for M548A3) or N (for M548A1) range and let carrier coast to stop. Do not use brakes or turn the steering wheel for the M548A3 or use the laterals on the M548A1. After carrier has stopped, shut off engine and exit carrier.</p>	

ITEM NO.	INTERVAL	MAN-HOUR	ITEM TO BE CHECKED OR SERVICED	CREWMEMBER PROCEDURE	EQUIPMENT NOT READY/ AVAILABLE IF:
				<p>a. Check for missing or damage track adjusters.</p> <p style="text-align: center;">WARNING</p> <div style="text-align: center;">  </div> <p>Not having the correct track tension during inspection can cause you to not see defective track parts that could cause track failure and loss of vehicle control. Soldiers can be killed or injured.</p> <p>Adjust track tension before inspecting track assembly and track shoes.</p> <p style="text-align: center;">CAUTION</p> <p>Track adjuster extended too far may buckle and become damaged during operation. Do not extend track adjuster beyond 17 inches (43 centimeters) (maximum), as measured between centers of track adjuster and mounting screws. Adjust track after vehicle has been unloaded of equipment.</p> <p style="text-align: center;">NOTE</p> <p>Use track pin punch for measurement of track adjuster. If longer than punch, remove track shoe.</p> <p>b. Adjust track tension as necessary (T130) (WP 0058 00) or (T150) (WP 0058 01).</p>	Track adjuster missing or unserviceable.

ITEM NO.	INTERVAL	MAN-HOUR	ITEM TO BE CHECKED OR SERVICED	CREWMEMBER PROCEDURE	EQUIPMENT NOT READY/ AVAILABLE IF:
----------	----------	----------	--------------------------------	----------------------	------------------------------------

T130 TRACK

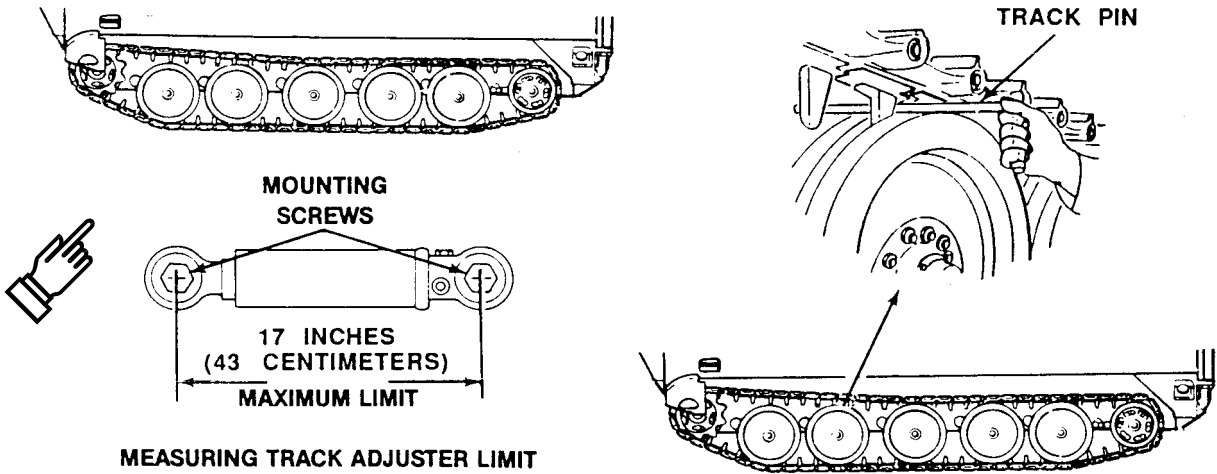

MEASURING TRACK ADJUSTER LIMIT

--	--	--	--	--	--

T150 TRACK

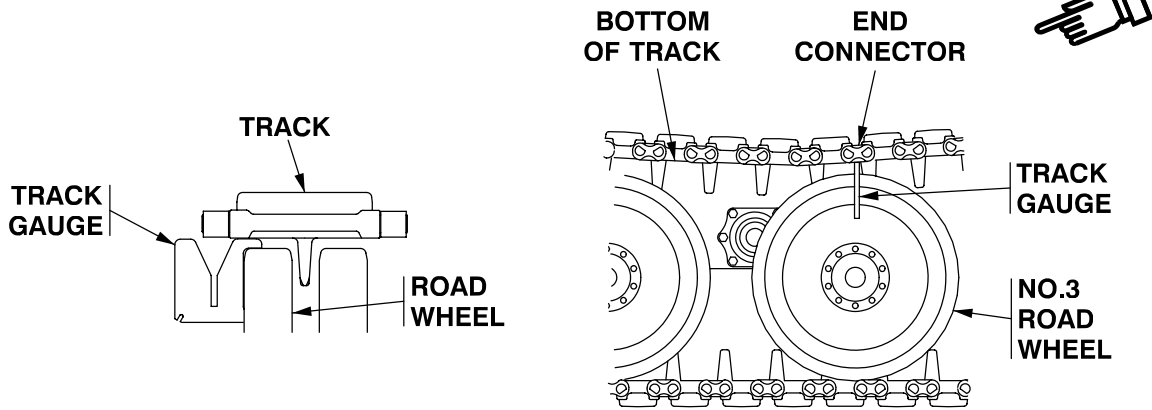

--	--	--	--	--	--

PREVENTIVE MAINTENANCE CHECKS AND SERVICES — Continued

0057 00

ITEM NO.	INTERVAL	MAN-HOUR	ITEM TO BE CHECKED OR SERVICED	CREWMEMBER PROCEDURE	EQUIPMENT NOT READY/ AVAILABLE IF:
14	Before		Track Shoes and Bushings (T130 Track Only)	<p>Driver</p> <p style="text-align: center;">WARNING</p>  <p>Failure to perform track PMCS and not repair or report to maintenance per technical manual procedures can allow you to operate the vehicle with defective track parts that could cause track failure and loss of vehicle control. Soldiers can be killed or injured.</p> <p>Never operate a vehicle without performing the BEFORE mission PMCS track tension adjustment and track inspection per PMCS procedures in the technical manual. Repair or report problems to maintenance per technical manual instructions as outlined in PMCS.</p>	

PREVENTIVE MAINTENANCE CHECKS AND SERVICES — Continued

0057 00

ITEM NO.	INTERVAL	MAN-HOUR	ITEM TO BE CHECKED OR SERVICED	CREWMEMBER PROCEDURE	EQUIPMENT NOT READY/ AVAILABLE IF:
				<p style="text-align: center;">WARNING</p> <div style="text-align: center;">  </div> <p>If you lose a track (break a track shoe or vehicle throws a track), extreme caution must be exercised in maintaining control. Immediately release accelerator and let the vehicle coast to a stop. Do not apply braking action, i.e. brake pedal, laterals, pivot, or any type of steering controls. This causes the vehicle to pull to the active or good track and could result in a rollover. It is absolutely necessary to apply braking action only and we stress only, if the vehicle is approaching a ravine, a cliff, or if you perceive the outcome to be catastrophic, probably resulting in fatalities. When a rollover is imminent, all crewmembers should immediately withdraw inside the vehicle, tighten seat belts and hold onto a secure fixture, until the vehicle comes to a complete stop.</p> <p>a. Move carrier one track length to inspect entire track.</p>	

PREVENTIVE MAINTENANCE CHECKS AND SERVICES — Continued

0057 00

ITEM NO.	INTERVAL	MAN-HOUR	ITEM TO BE CHECKED OR SERVICED	CREWMEMBER PROCEDURE	EQUIPMENT NOT READY/ AVAILABLE IF:
				<ol style="list-style-type: none"> 1) Visually check for unusual or uneven gaps between two adjacent shoes. Check any suspect bushing using the track and sprocket gauge. If a "NO/GO" reading is obtained on either the inside or outside of the block, the unserviceable shoe/shoes must be replaced. 2) Check track shoe for damaged pins, missing pin nuts, and any unusual or uneven gaps between two adjacent track shoes which indicate worn bushings. <p style="text-align: center;">NOTE</p> <p>Worn or missing track pads will cause the track shoe to mark the road surface.</p> <ol style="list-style-type: none"> 3) Replace worn or missing track pads and track pad nuts. 	<p>Any unserviceable shoe.</p> <p>Any one track shoe body bent, cracked, or broken. Any one track pin bent, broken, or missing.</p>

ITEM NO.	INTERVAL	MAN-HOUR	ITEM TO BE CHECKED OR SERVICED	CREWMEMBER PROCEDURE	EQUIPMENT NOT READY/ AVAILABLE IF:
<p>T130 TRACK</p> <p>CORRECT ALIGNMENT</p> <p>INCORRECT ALIGNMENT</p>					

ITEM NO.	INTERVAL	MAN-HOUR	ITEM TO BE CHECKED OR SERVICED	CREWMEMBER PROCEDURE	EQUIPMENT NOT READY/ AVAILABLE IF:
				<p>4) Check track shoe for damaged pins, missing pin nuts, and any unusual or uneven gaps between two adjacent track shoes which indicates worn bushings.</p> <p style="text-align: center;">NOTE</p> <p>Worn bushings are very difficult to locate. Worn bushings may cause the track pin to appear off-center; it may have protruding track pin or track pin nut, or unusual gaps between two adjacent shoes.</p>	<p>Any one shoe with worn bushing, protruding track pin, missing track pin nut, or pad height is less than 1/16 inch above grouser. Any one bushing deemed unserviceable.</p>

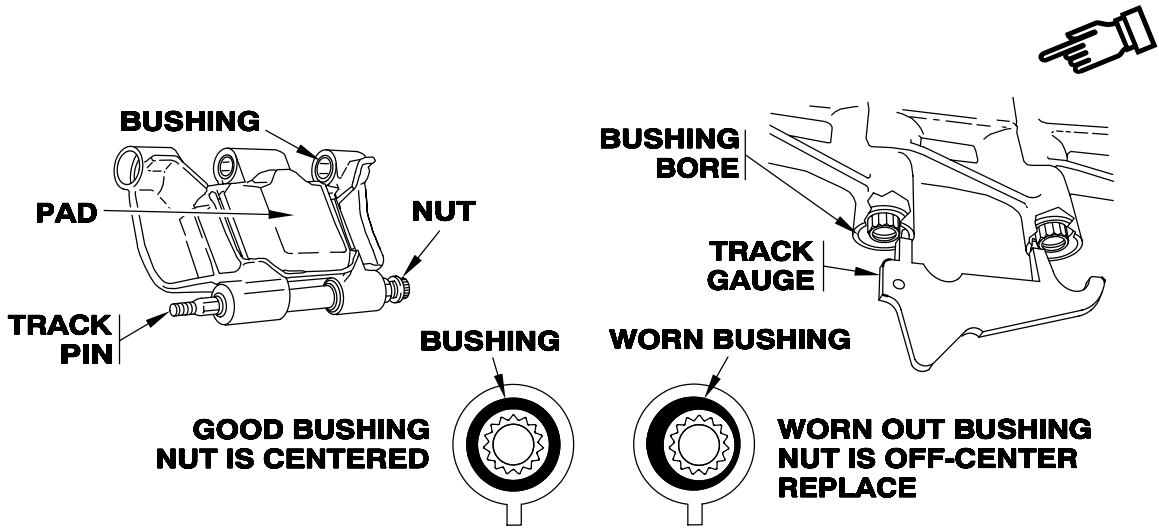

PREVENTIVE MAINTENANCE CHECKS AND SERVICES — Continued

0057 00

ITEM NO.	INTERVAL	MAN-HOUR	ITEM TO BE CHECKED OR SERVICED	CREWMEMBER PROCEDURE	EQUIPMENT NOT READY/ AVAILABLE IF:
				<p style="text-align: center;">NOTE</p> <p>Check left and right side of vehicle for damage to track shoes.</p> <p>5) Check for any suspect bushings which should be tested with the track and sprocket gauge. Gauge pins must be fully inserted into bushing bore. Any track shoe failing track gauge inspection is unserviceable. Replace any worn shoe bushing with shoe.</p>	<p>Any one track shoe with worn bushing, protruding track pin, or missing track pin nut. Any one bushing deemed unserviceable.</p>

PREVENTIVE MAINTENANCE CHECKS AND SERVICES — Continued

0057 00

ITEM NO.	INTERVAL	MAN-HOUR	ITEM TO BE CHECKED OR SERVICED	CREWMEMBER PROCEDURE	EQUIPMENT NOT READY/ AVAILABLE IF:
15	Before		Track Shoes and Bushings (T150 Only)	<p>DRIVER</p> <p style="text-align: center;">WARNING</p>  <p>Failure to perform track PMCS and not repair or report to maintenance per technical manual procedures can allow you to operate the vehicle with defective track parts that could cause track failure and loss of vehicle control. Soldiers can be killed or injured.</p> <p>Never operate a vehicle without performing the BEFORE mission PMCS track tension adjustment and track inspection per PMCS procedures in the technical manual. Repair or report problems to maintenance per technical manual instructions as outlined in PMCS.</p>	

ITEM NO.	INTERVAL	MAN-HOUR	ITEM TO BE CHECKED OR SERVICED	CREWMEMBER PROCEDURE	EQUIPMENT NOT READY/ AVAILABLE IF:
				<p style="text-align: center;">WARNING</p> <div style="text-align: center;">  </div> <p>If you lose a track (break a track shoe or vehicle throws a track), extreme caution must be exercised in maintaining control. Immediately release accelerator and let the vehicle coast to a stop. Do not apply braking action, i.e. brake pedal, laterals, pivot, or any type of steering controls. This causes the vehicle to pull to the active or good track and could result in a rollover. It is absolutely necessary to apply braking action only and we stress only, if the vehicle is approaching a ravine, a cliff, or if you perceive the outcome to be catastrophic, probably resulting in fatalities. When a rollover is imminent, all crewmembers should immediately withdraw inside the vehicle, tighten seat belts and hold onto a secure fixture, until the vehicle comes to a complete stop.</p> <p>a. Move carrier one track length to inspect engine track.</p>	

ITEM NO.	INTERVAL	MAN-HOUR	ITEM TO BE CHECKED OR SERVICED	CREWMEMBER PROCEDURE	EQUIPMENT NOT READY/ AVAILABLE IF:
				<ol style="list-style-type: none"> 1) Check for any broken track shoes (cracked or broken shoe body) bent, broken, or missing center guides, chunked or missing road wheel path. If one or more track shoes or three or more center guides in a row are broken, notify unit maintenance. 2) Check center guide wear. Use track wear gauge (WP 0081 00, Item 21A). If three or more center guides in a row show excessive wear, notify unit maintenance. <p style="text-align: center;">NOTE</p> <p>Worn or missing track shoe pads will cause track shoe to wear out prematurely and mark road surface.</p> <ol style="list-style-type: none"> 3) Check track shoe for worn or missing track pads/pad nuts. 	<p>One or more broken track shoes. Three or more broken center guides in a row.</p> <p>Three or more center guides in a row show excessive wear.</p>

T150 TRACK

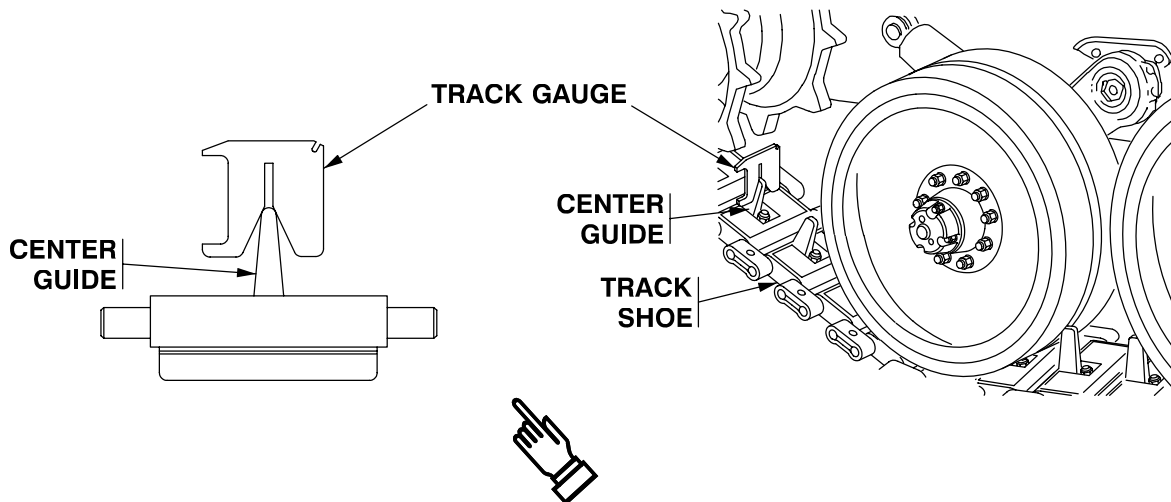

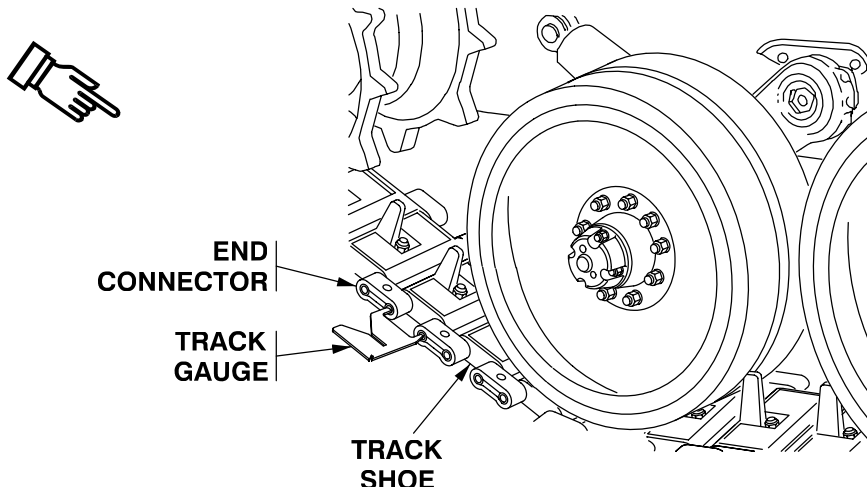
ITEM NO.	INTERVAL	MAN-HOUR	ITEM TO BE CHECKED OR SERVICED	CREWMEMBER PROCEDURE	EQUIPMENT NOT READY/ AVAILABLE IF:
			<p>T150 TRACK</p>  <p>The diagram illustrates the T150 track assembly. It shows a track shoe mounted on a track pin, which is held in place by an end connector. A track gauge is used to check the wear of the track pin bushing. Labels with arrows point to the 'END CONNECTOR', 'TRACK GAUGE', and 'TRACK SHOE'.</p>	<p>4) Check track shoe for cracked, missing, or loose end connectors/bolts. Tighten loose end connectors/bolts. Notify unit maintenance to torque any bolts you had to tighten.</p> <p>5) Check for track pin bushing wear. Use track wear gauge (WP 0081 00, Item 21A) when worn bushings are visible. If track gauge does not move freely inside track pin, notify maintenance.</p>	<p>If one or more end connectors/bolts are cracked, damaged, loose, or missing.</p> <p>Track gauge does not move freely inside track pin.</p>

PREVENTIVE MAINTENANCE CHECKS AND SERVICES — Continued

0057 00

ITEM NO.	INTERVAL	MAN-HOUR	ITEM TO BE CHECKED OR SERVICED	CREWMEMBER PROCEDURE	EQUIPMENT NOT READY/ AVAILABLE IF:
16	Before		Driver's Seat and Lap Seat Belt	<p>DRIVER</p> <p>a. Check for smooth operation of seat, horizontal control handle as needed with OE/HDO. See WP 0010 00 for seat adjustments.</p> <p>b. Check seat belts for operation and condition of belts, belt buckle, and belt tongue.</p>	Any missing, broken, or cracked seat hardware; less seat cushions; or cut, frayed seat belts; or missing seat.

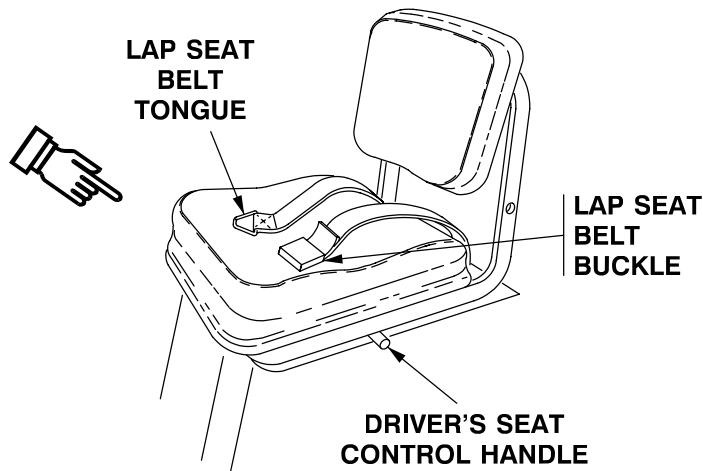

PREVENTIVE MAINTENANCE CHECKS AND SERVICES — Continued

0057 00

ITEM NO.	INTERVAL	MAN-HOUR	ITEM TO BE CHECKED OR SERVICED	CREWMEMBER PROCEDURE	EQUIPMENT NOT READY/ AVAILABLE IF:
17	Before		Passenger's Seats and Lap Seat Belt	<p>TRACK COMMANDER</p> <p>a. Check seats and cushions/backrests for condition, properly secured.</p> <p>b. Check seat belts for operation and condition of belts, belt buckle, and belt tongue.</p>	Any missing, broken, or cracked seat hardware; less seat cushions; or cut, frayed seat belts; or missing seat.

Table 17. Preventive Maintenance Checks and Services for M548A1/M548A3, During

ITEM NO.	INTERVAL	MAN-HOUR	ITEM TO BE CHECKED OR SERVICED	CREWMEMBER PROCEDURE	EQUIPMENT NOT READY/ AVAILABLE IF:
18	During		Instrument Panel Warning Lights and Gauges	<p>DRIVER</p> <p style="text-align: center;">CAUTION</p> <p>Do not operate carrier if oil HI-TEMP-LO-PRESS (M548A1) ENGINE OIL LOW PRESS (M548A3) warning light comes on with engine running. Engine can be damaged. If ENGINE OIL LOW PRESS or HI-TEMP-LOW warning light does not go off within 5-10 seconds after engine starts, stop engine (WP 0023 00) (for the M548A1) and (WP 0024 00) (for the M548A3).</p> <p style="text-align: center;">NOTE</p> <p>TRANS OIL LOW PRESS warning light may come on when brakes are released, but light should go off when engine speed reaches about 1400 rpm on M548A3 only.</p> <p>a. During carrier operation, check instrument panel warning lights and gauges periodically for possible carrier malfunctions. Panel indicators should read as follows:</p> <ol style="list-style-type: none"> 1) Warning lights - all OFF. 2) Battery Generator indicator - in green zone. 	<p>Any warning light comes on.</p> <p>Gauge is not in green zone.</p>

PREVENTIVE MAINTENANCE CHECKS AND SERVICES — Continued

0057 00

ITEM NO.	INTERVAL	MAN-HOUR	ITEM TO BE CHECKED OR SERVICED	CREWMEMBER PROCEDURE	EQUIPMENT NOT READY/ AVAILABLE IF:
				<p style="text-align: center;">CAUTION</p> <p>Damage to the engine will occur if the temperature gauge exceeds 230°F (110°C).</p> <p>3) Coolant Temperature Gauge - If outside air temperature is less than 85°F (29.44°C), normal coolant temperature should be 160-230°F (71.1-110°C).</p> <p>b. Report any abnormal indications to unit maintenance. For a complete description of warning lights and gauges, see WP 0004 00.</p>	<p>Outside air temperature is less than 85°F (29.44°C) and gauge is above 200°F (93.3°C). If outside air temperature is greater than 85°F (29.44°C) and gauge is above 230°F (110°C), notify unit maintenance immediately.</p>

PREVENTIVE MAINTENANCE CHECKS AND SERVICES — Continued

0057 00

ITEM NO.	INTERVAL	MAN-HOUR	ITEM TO BE CHECKED OR SERVICED	CREWMEMBER PROCEDURE	EQUIPMENT NOT READY/ AVAILABLE IF:
19	During		Steering, Braking, Shifting, and Throttle Controls (M548A1)	<p>DRIVER</p> <p style="text-align: center;">WARNING</p>  <p>Sudden carrier movement can throw you out of seat. Wear seat belt while carrier is in motion. Do not use any seat with missing or inoperative seat belt.</p>	

ITEM NO.	INTERVAL	MAN-HOUR	ITEM TO BE CHECKED OR SERVICED	CREWMEMBER PROCEDURE	EQUIPMENT NOT READY/ AVAILABLE IF:
				<p style="text-align: center;">WARNING</p> <div style="text-align: center;">  </div> <p>When vehicle is moving, pushing down on steering lever lock buttons can cause brake(s) to be locked. Personnel can be killed or injured. Perform steering and braking PMCS only when the engine is stopped.</p> <p>When steering and braking occurs before first notch or after fourth notch on the quadrant, vehicle can skid and crash, causing personnel to be killed or injured. If steering and braking is not between second and third notch, do not operate vehicle. Notify unit maintenance.</p> <p>If left and right steering lever positions are not within one notch difference on the quadrant during braking, carrier can skid and crash, causing personnel to be killed or injured. Do not operate carrier. Notify unit maintenance.</p>	



PREVENTIVE MAINTENANCE CHECKS AND SERVICES — Continued

0057 00

ITEM NO.	INTERVAL	MAN-HOUR	ITEM TO BE CHECKED OR SERVICED	CREWMEMBER PROCEDURE	EQUIPMENT NOT READY/ AVAILABLE IF:
				<ul style="list-style-type: none"> a. Check controls and be alert for binding, grabbing, looseness, or malfunctions. b. Operate the differential steering levers, pivot steering levers, and shift lever in all ranges, the hand throttle, and accelerator pedal. c. Get to know your carrier's response to these controls. 	<p>If there is a noticeable difference between left and right steering levers in excess of one notch on the quadrant when both levers are in the fully applied position.</p> <p>Steering lever travel is less than the second notch or more than the fourth notch on the quadrant in the fully applied position.</p>

PREVENTIVE MAINTENANCE CHECKS AND SERVICES — Continued

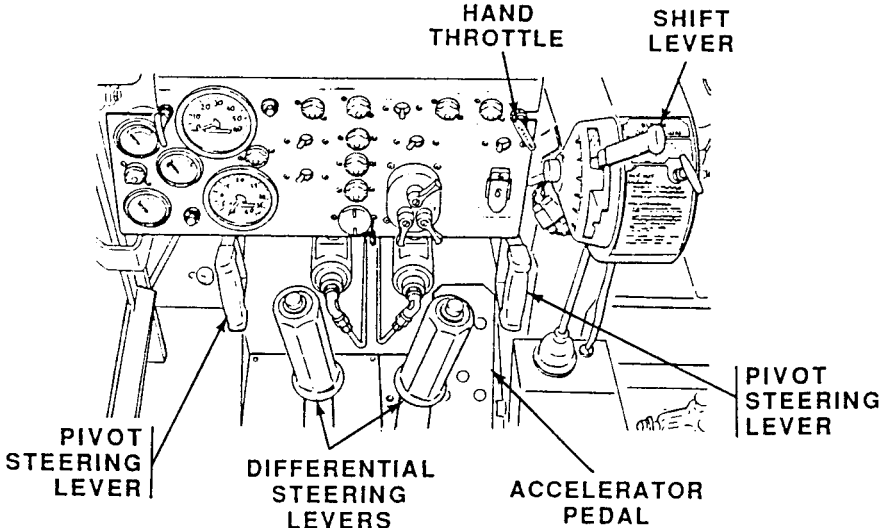
0057 00

ITEM NO.	INTERVAL	MAN-HOUR	ITEM TO BE CHECKED OR SERVICED	CREWMEMBER PROCEDURE	EQUIPMENT NOT READY/ AVAILABLE IF:
20	During		Steering, Braking, Shifting, and Throttle Controls (M548A3)	<p>d. If the response does not feel right or if the response changes, report it to unit maintenance.</p> <div style="text-align: center;">  </div> <p>DRIVER</p> <div style="text-align: center;"> <p>WARNING</p>  <p>Sudden carrier movement can throw you out of seat. Wear seat belt while carrier is in motion. Do not use any seat with missing or inoperative seat belt.</p> </div>	

ITEM NO.	INTERVAL	MAN-HOUR	ITEM TO BE CHECKED OR SERVICED	CREWMEMBER PROCEDURE	EQUIPMENT NOT READY/AVAILABLE IF:
				<p style="text-align: center;">CAUTION</p> <p>Replacement of several track pads on one side of carrier could result in carrier drift.</p> <ol style="list-style-type: none"> a. Check the following controls: b. Be alert for binding, grabbing, looseness, or malfunction. For correct operating procedures, see WP 0021 00. c. Operate the hand throttle, accelerator pedal, brake pedal, parking brake handle, and steering wheel. Operate transmission shift controller in all ranges. d. Get to know your carrier's response to these controls. e. If there is any noticeable drift of carrier during operation, notify unit maintenance. 	<p>Brakes do not stop carrier. Binding, grabbing, unusual noise, or vibration occurs during operation of controls.</p>
				<p>The diagram shows a top-down view of the operator's control station. Labels with arrows point to the following components: STEERING WHEEL (left side), HAND THROTTLE (center), RANGE SELECTOR (right side), PARKING BRAKE HANDLE (left side, below steering wheel), BRAKE PEDAL (center, below hand throttle), and ACCELERATOR PEDAL (right side, below range selector).</p>	

PREVENTIVE MAINTENANCE CHECKS AND SERVICES — Continued

0057 00

ITEM NO.	INTERVAL	MAN-HOUR	ITEM TO BE CHECKED OR SERVICED	CREWMEMBER PROCEDURE	EQUIPMENT NOT READY/ AVAILABLE IF:
			M548A3	<p>PERSONNEL/EQUIPMENT SAFETY, CARRIER OPERATION HANDLING</p> <p style="text-align: center;">WARNING</p>  <p>Carrier can pivot steer when engine is running, transmission is in SL (steering wheel locked), and steering wheel is unlocked. This could result in personnel injury or death. Install steering wheel lock safety pin before leaving carrier. Do not use the steering wheel as a grip handle when entering or leaving the cab.</p> <p>Do not leave driver's seat if you haven't:</p> <ol style="list-style-type: none"> 1) Installed steering wheel lock safety pin. 2) Set parking brake and put transmission shift controller in SL position. <p>Avoid oversteering at high speeds to prevent skidding or carrier upset. Use caution when turning on hills or side slopes. If you break a track shoe or carrier throws a track, use extreme CAUTION to maintain carrier control. Immediately release accelerator and let carrier coast to a stop. Do not use brake or steering controls unless you are about to enter a more hazardous situation.</p>	

ITEM NO.	INTERVAL	MAN-HOUR	ITEM TO BE CHECKED OR SERVICED	CREWMEMBER PROCEDURE	EQUIPMENT NOT READY/ AVAILABLE IF:
21	During		Braking Controls	<p>DRIVER</p> <p>a. The following check requires the engine to be running:</p> <p style="text-align: center;">NOTE</p> <p>Parking brake handle only supplies adequate force to lock the service brake. Handle will not supply enough force to actuate service brake.</p> <p>b. Depress brake pedal as hard as possible.</p> <p>c. Apply parking brake (pull up on handle).</p> <p>d. If brake pedal is held firmly or moves downward slightly, parking brake adjustment is OK.</p> <p>e. If any upward movement of brake pedal is noticed, parking brake must be adjusted. Notify unit maintenance.</p> <p>f. Notify unit maintenance if parking brake will not hold or parking brake handle can be moved very easily.</p>	Parking brake will not hold or handle can be moved up and down freely.
22	During		Air Cleaner Restriction Indicator	DRIVER	

ITEM NO.	INTERVAL	MAN-HOUR	ITEM TO BE CHECKED OR SERVICED	CREWMEMBER PROCEDURE	EQUIPMENT NOT READY/ AVAILABLE IF:
				<p style="text-align: center;">CAUTION</p> <p>Do not operate carrier if air cleaner element is missing or door gasket is missing or damaged. Extensive damage to engine will result.</p> <ol style="list-style-type: none"> a. Check air cleaner restriction indicator with engine running. b. Observe air cleaner indicator window. c. If at any time you see only red in the window and button does not reset when pushed in, notify unit maintenance. d. For air cleaner maintenance, see WP 0063 00 or WP 0064 00. 	<p>Air restriction indicator remains red after resetting. Air cleaner element, door, or door gasket is missing or damaged.</p>

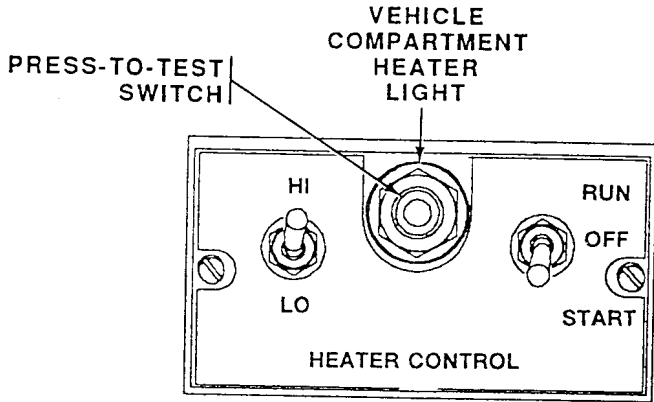
ITEM NO.	INTERVAL	MAN-HOUR	ITEM TO BE CHECKED OR SERVICED	CREWMEMBER PROCEDURE	EQUIPMENT NOT READY/ AVAILABLE IF:
23	During		Vehicle Compartment Heater Electrical Circuits	<p>DRIVER</p> <p style="text-align: center;">NOTE</p> <p>Item is to be checked only if heater is to be used during operation.</p> <ol style="list-style-type: none"> a. Check the operation of the vehicle compartment heater electrical circuits. b. Push the press-to-test light cover and see that the indicator light comes on before you start the heater. c. When you turn the heater off, make sure the indicator light stays on and the blower runs until the heater cools down. <div style="text-align: center;">  <p>The diagram shows a rectangular control panel labeled 'HEATER CONTROL'. It features three rotary switches. The leftmost switch has positions 'HI' and 'LO'. The middle switch is a 'PRESS-TO-TEST SWITCH' with a 'VEHICLE COMPARTMENT HEATER LIGHT' indicator. The rightmost switch has positions 'RUN' and 'OFF'. A 'START' button is located at the bottom right of the panel.</p> </div>	
24	During		Vehicle Compartment Heater	DRIVER	

ITEM NO.	INTERVAL	MAN-HOUR	ITEM TO BE CHECKED OR SERVICED	CREWMEMBER PROCEDURE	EQUIPMENT NOT READY/ AVAILABLE IF:
				<p style="text-align: center;">NOTE</p> <p>Item will be checked only if heater is to be used during operation.</p> <p>a. Check to make sure nothing is blocking the vehicle compartment heater exhaust, air inlet, or heat ducts. Check for leaks in the fuel lines. [See WP 0002 00 for M548A3.</p>	<p>Any fuel leak.</p>

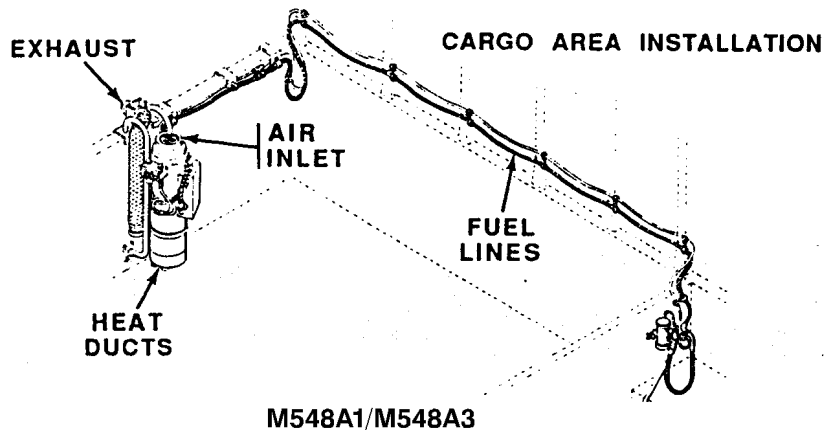
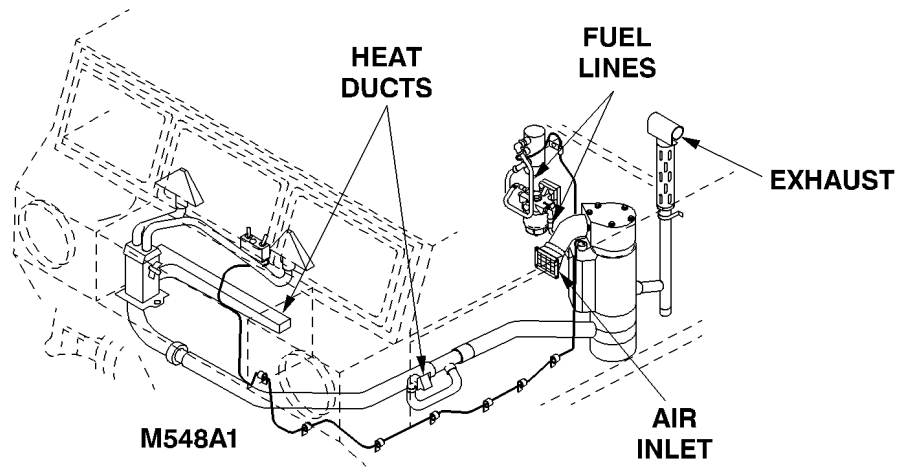

ITEM NO.	INTERVAL	MAN-HOUR	ITEM TO BE CHECKED OR SERVICED	CREWMEMBER PROCEDURE	EQUIPMENT NOT READY/ AVAILABLE IF:
25	During		Coolant Heater (if installed)	<p>DRIVER</p> <ol style="list-style-type: none"> a. Check to make sure nothing is blocking the coolant heater exhaust or air inlet. b. Inspect for leaks in fuel lines and coolant lines. c. Make sure the coolant valves are open before you start the heater. d. <input type="checkbox"/> See WP 0002 00 for M548A3. 	Any fuel leak.

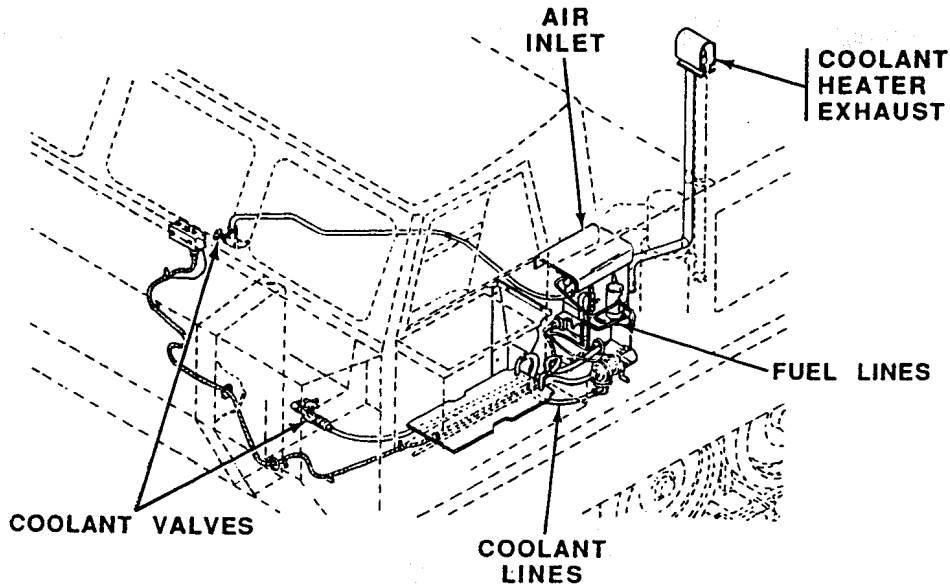

PREVENTIVE MAINTENANCE CHECKS AND SERVICES — Continued

0057 00

ITEM NO.	INTERVAL	MAN-HOUR	ITEM TO BE CHECKED OR SERVICED	CREWMEMBER PROCEDURE	EQUIPMENT NOT READY/ AVAILABLE IF:
26	During		Coolant Heater (Electrical Circuits)	<p>DRIVER</p> <p style="text-align: center;">NOTE</p> <p>Item will be checked only if heater is to be used during operation.</p> <p>a. Push the press-to-test light cover and see that the indicator light comes on before you start the heater.</p> <div style="text-align: center;">  </div>	

Table 18. Preventive Maintenance Checks and Services for M548A1/M548A3, After

ITEM NO.	INTERVAL	MAN-HOUR	ITEM TO BE CHECKED OR SERVICED	CREWMEMBER PROCEDURE	EQUIPMENT NOT READY/AVAILABLE IF:
27	After		Material Handling Kit Lifting Sling (if equipped)	<p>CREWMEMBER</p> <p style="text-align: center;">NOTE</p> <p>Reference: TB 43-0142, Safety Inspection and Testing of Lifting Devices, 28 Feb 97</p> <ol style="list-style-type: none"> a. Check that beam stops are in place on each end of I-beam. Replace missing stops. Inspect beam lock and trolley lock for proper operation. b. Inspect/check hoist chains and hook for evidence of wear, damage, bends, or distortions. Check for any grabbing or binding of chains. c. Check lifting sling. Webbing must be of uniform thickness. Inspect for evidence of chemical damage, snags, punctures, tears, cuts, and broken or worn stitching. d. Check sling end fittings for distortion or sharp edges. Replace damaged sling. 	<p>Stops missing.</p> <p>Bent hook or damaged chains.</p> <p>Any evidence of damage.</p>

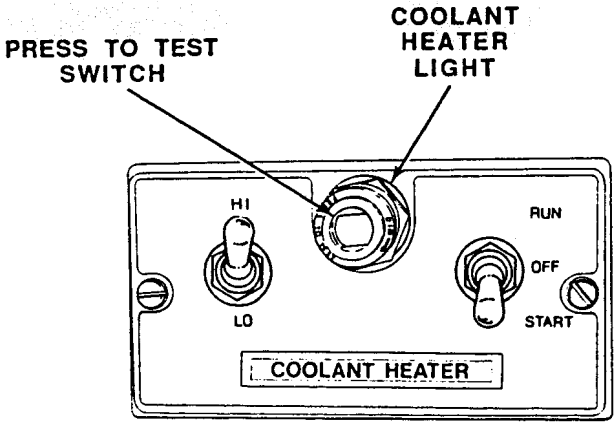
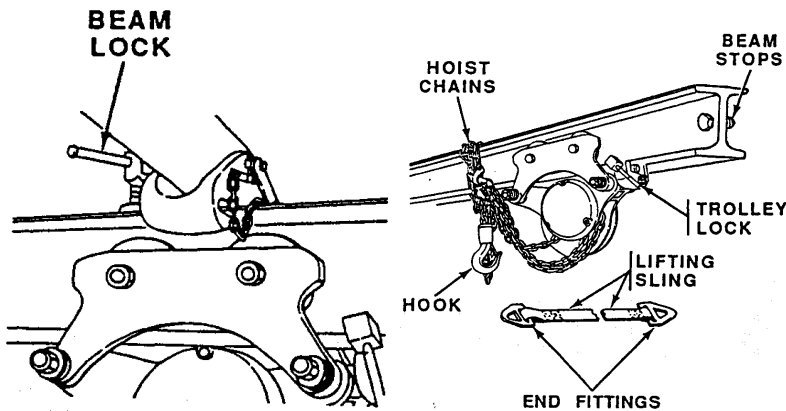
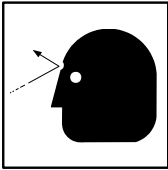
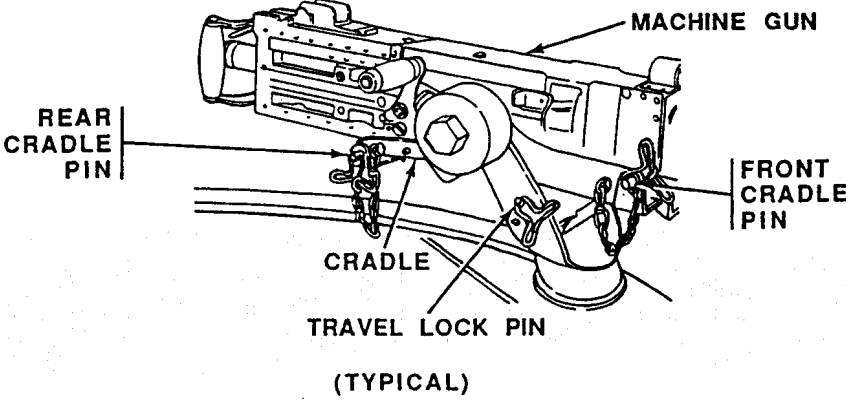

ITEM NO.	INTERVAL	MAN-HOUR	ITEM TO BE CHECKED OR SERVICED	CREWMEMBER PROCEDURE	EQUIPMENT NOT READY/ AVAILABLE IF:
28	After		Gun Mount Installation (if equipped)	<p>TRACK COMMANDER</p> <p style="text-align: center;">WARNING</p>  <p>Make sure machine gun is clear of ammo and barrel is free of obstructions.</p> <ol style="list-style-type: none"> <input type="checkbox"/> Check that gun mount is complete, and cradle pin, bolts, and ring are undamaged and securely mounted. If ammunition is present, see that ammunition boxes are stowed right. Be sure gun is locked in travel position, unless machine gun is required for immediate use. If M3 tripod mount is present, make sure it is stowed securely to the rear supports. See TM 9-1005-213-10 (M2), or TM 9-1005-224-10 (M60) for machine gun PMCS. 	

PREVENTIVE MAINTENANCE CHECKS AND SERVICES — Continued

0057 00

ITEM NO.	INTERVAL	MAN-HOUR	ITEM TO BE CHECKED OR SERVICED	CREWMEMBER PROCEDURE	EQUIPMENT NOT READY/AVAILABLE IF:
29	After	0.2	Transmission Oil Level (Hot Check) (M548A1)	<p>DRIVER/COMMANDER</p> <p style="text-align: center;">WARNING</p> <div style="text-align: center;">  </div> <p>Make sure carrier is on level surface and the brakes are set and locked.</p> <p>Carrier could move, causing serious injury to personnel and damage to the carrier.</p>	

PREVENTIVE MAINTENANCE CHECKS AND SERVICES — Continued

0057 00

ITEM NO.	INTERVAL	MAN-HOUR	ITEM TO BE CHECKED OR SERVICED	CREWMEMBER PROCEDURE	EQUIPMENT NOT READY/ AVAILABLE IF:
				<p>a. Pull back on both steering levers and press the lock buttons down.</p> <p>b. Check transmission oil level while engine is running at a temperature of 160 to 230°F (71.1 to 110°C) and 1500 rpm.</p> <p>c. If engine is not up to operating temperature, put transmission range selector in 2-3 range and run the engine at 1000 rpm for 3-5 minutes.</p> <p>d. Reduce engine speed to idle (650-700 rpm) and move the shift lever through the ranges.</p> <p>e. Put transmission range selector in neutral (N) and set the hand throttle to run engine at 1500 rpm.</p> <p>f. Check transmission oil dipstick.</p> <p>g. Oil level should be between ADD and FULL/HOT.</p> <p>h. Carrier may be safely operated when oil shows between ADD and FULL/HOT.</p> <p>i. <input type="checkbox"/> Add oil as needed. <input type="checkbox"/> Do not overfill. <input type="checkbox"/> For lubricant information, see Table 5, page 0057 00-7. <input type="checkbox"/></p>	Any Class III leak.

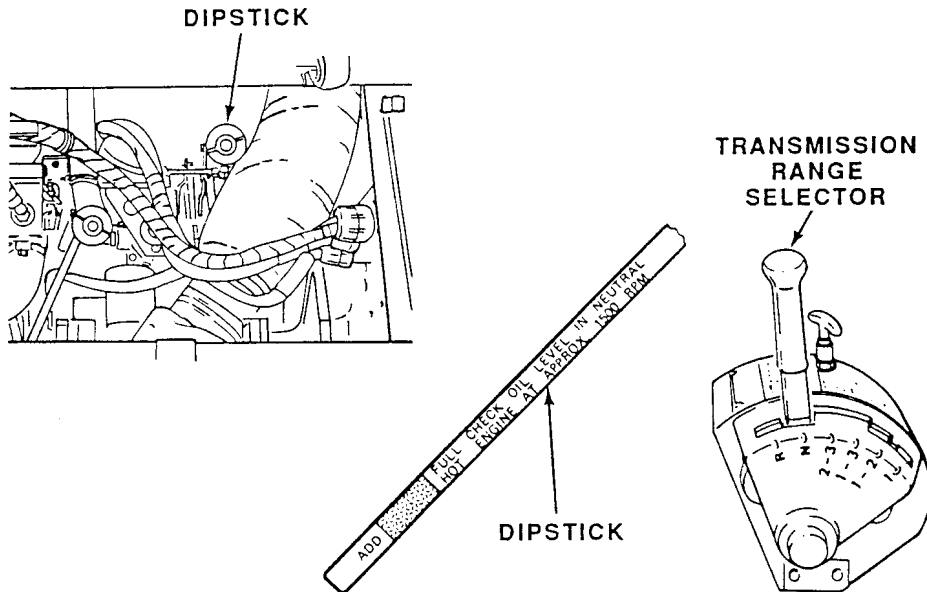

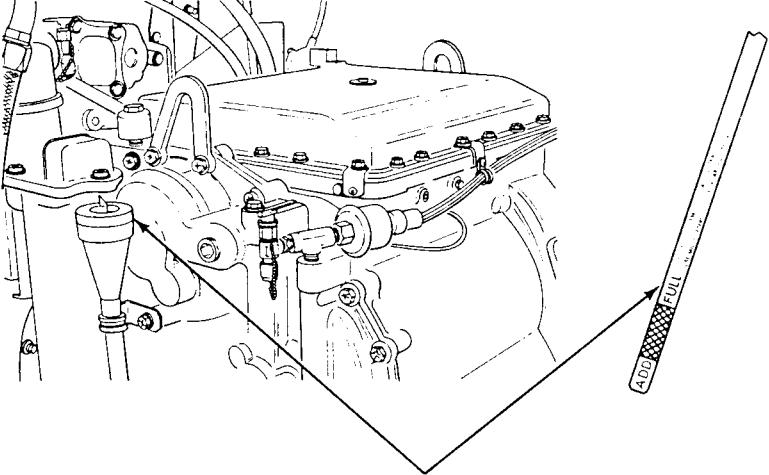
ITEM NO.	INTERVAL	MAN-HOUR	ITEM TO BE CHECKED OR SERVICED	CREWMEMBER PROCEDURE	EQUIPMENT NOT READY/ AVAILABLE IF:
30	After		Transmission Oil Level (M548A3)	<p>DRIVER</p> <p style="text-align: center;">NOTE</p> <p>Carrier must be on level surface when checking oil level.</p> <ol style="list-style-type: none"> a. Check transmission oil level. b. Stop engine (WP 0024 00). c. Oil level should be between ADD and FULL marks on transmission gauge rod. <p style="text-align: center;">NOTE</p> <p>There is approximately 1 gallon capacity between add and full mark.</p> <ol style="list-style-type: none"> d. Add oil as needed. Do not overfill. For lubricant information, see Table 4, page 0057 00-7. <div style="text-align: center;">  <p>TRANSMISSION GAUGE ROD</p> </div>	<p>Any sign of Class III leak.</p> <p>Oil level not within operating range.</p>

PREVENTIVE MAINTENANCE CHECKS AND SERVICES — Continued

0057 00

ITEM NO.	INTERVAL	MAN-HOUR	ITEM TO BE CHECKED OR SERVICED	CREWMEMBER PROCEDURE	EQUIPMENT NOT READY/ AVAILABLE IF:
31	After		Engine Shutdown	<p>DRIVER</p> <ol style="list-style-type: none"> a. Check engine for proper shutdown. b. Reduce engine speed to normal idle (650-700 rpm). c. Allow engine to idle 3-5 minutes until normal idle operating temperature (160 to 220°F) (71.1 to 104.4°C) is reached. d. Pull fuel cut-off to stop engine. e. Inspect fuel cut-off cable for any binding, grabbing, or looseness that would prevent the engine from being shut down. 	Engine won't shut down.

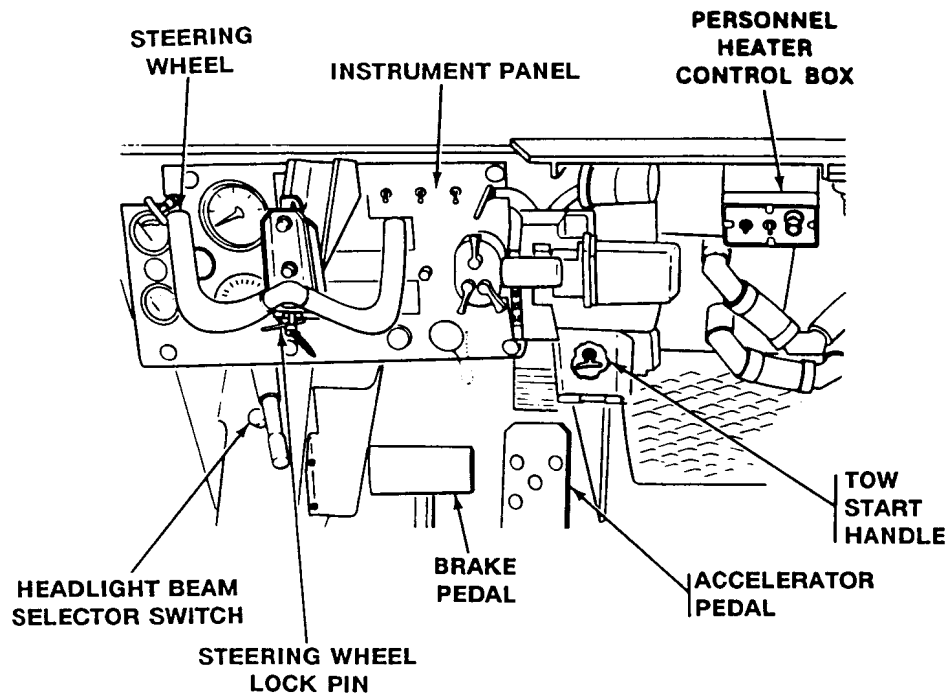

ITEM NO.	INTERVAL	MAN-HOUR	ITEM TO BE CHECKED OR SERVICED	CREWMEMBER PROCEDURE	EQUIPMENT NOT READY/ AVAILABLE IF:
32	After	0.1	Engine Oil Level (M548A1)	<p>DRIVER</p> <p style="text-align: center;">CAUTION</p> <p>Carrier must be on level surface when checking oil level.</p> <p style="text-align: center;">NOTE</p> <p>Oil level between “L” and “F” is OK on a cold check. Oil level should not be above the “F” (Full) mark.</p> <ol style="list-style-type: none"> a. Check oil level of engine. b. Oil level on engine dipstick should be between L (low) and F (full). c. Add oil as necessary. Do not overfill. For lubricant information, see Table 2, page 0057 00-6. 	<p>Class III leak.</p> <p>Oil level not within operating range.</p>

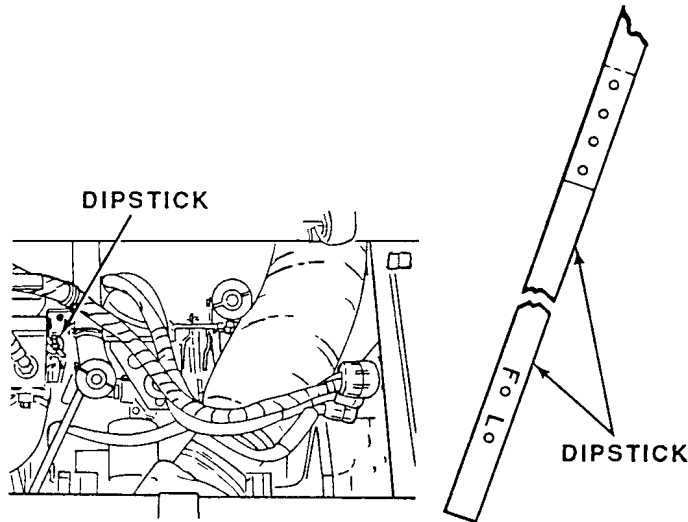

ITEM NO.	INTERVAL	MAN-HOUR	ITEM TO BE CHECKED OR SERVICED	CREWMEMBER PROCEDURE	EQUIPMENT NOT READY/ AVAILABLE IF:
33	After	0.1	Engine Oil Level (M548A3)	<p>DRIVER</p> <p style="text-align: center;">NOTE</p> <p>Carrier must be on level surface when checking oil level.</p> <ol style="list-style-type: none"> a. Check oil level of engine. b. Oil level on engine gauge rod should read between L (low) and F (full). <p style="text-align: center;">NOTE</p> <p>There is approximately 2 quarts capacity between low and full.</p> <ol style="list-style-type: none"> c. Add oil as necessary. Do not overfill. For lubricant information, see Table 3, page 0057 00-6. Oil level should not be above F (Full) mark. 	<p>Any Class III leak.</p> <p>Oil level not within operating range.</p>

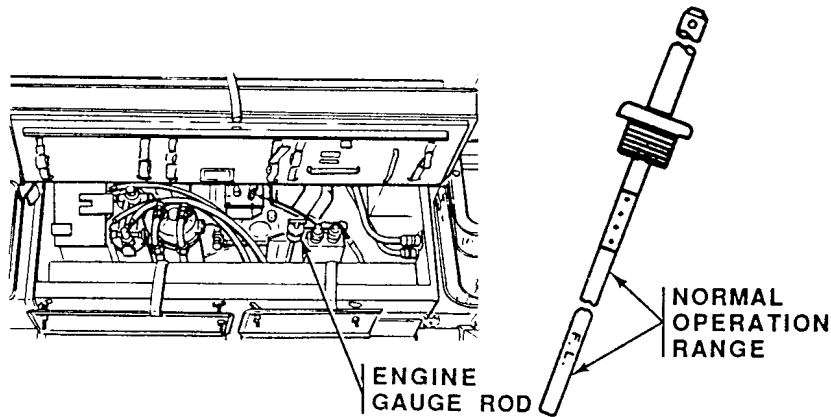

PREVENTIVE MAINTENANCE CHECKS AND SERVICES — Continued

0057 00

ITEM NO.	INTERVAL	MAN-HOUR	ITEM TO BE CHECKED OR SERVICED	CREWMEMBER PROCEDURE	EQUIPMENT NOT READY/ AVAILABLE IF:
34	After	0.4	Differential Oil (M548A1)	<p>DRIVER</p> <p style="text-align: center;">NOTE</p> <p>If engine has been running, wait 10 to 15 minutes after stopping engine before checking differential oil level.</p> <ol style="list-style-type: none"> a. Check oil level of the differential. b. Oil level on dipstick should be between ADD and FULL. c. Add oil as necessary. Do not overfill. For lubricant information, see Table 7, page 0057 00-8. 	Any Class III leak.

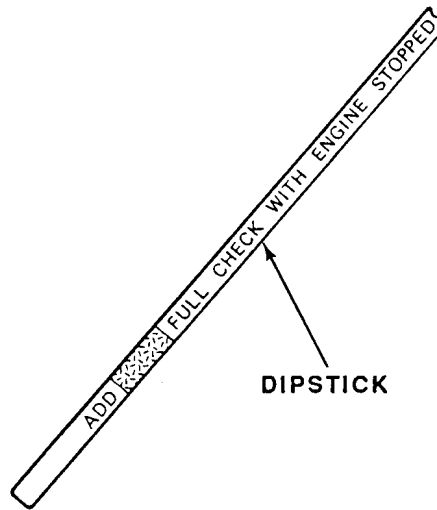
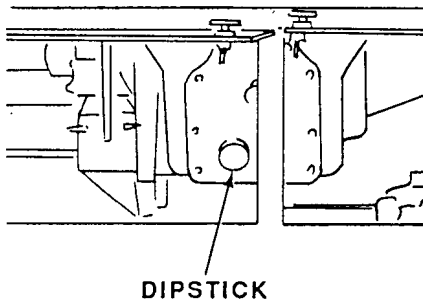

PREVENTIVE MAINTENANCE CHECKS AND SERVICES — Continued

0057 00

ITEM NO.	INTERVAL	MAN-HOUR	ITEM TO BE CHECKED OR SERVICED	CREWMEMBER PROCEDURE	EQUIPMENT NOT READY/ AVAILABLE IF:
35	After		Propeller Shafts, Universal Joints (Three Locations, M548A1) (Two Locations, M548A3)	<p>DRIVER</p> <p>a. Check propeller shafts, universal joints, mating coupling, and yokes for loose or missing mounting hardware, corrosion, and evidence of wear/damage.</p>	Any bolts or washers loose, broken, or missing.
36	After		Propeller Shafts, Universal Joints, and Yokes	<p>DRIVER</p> <p>a. Inspect left and right propeller shafts, universal joints, mating coupling, and yokes for loose or missing mounting hardware, corrosion, and evidence of wear/damage.</p>	Any loose or missing mounting hardware.

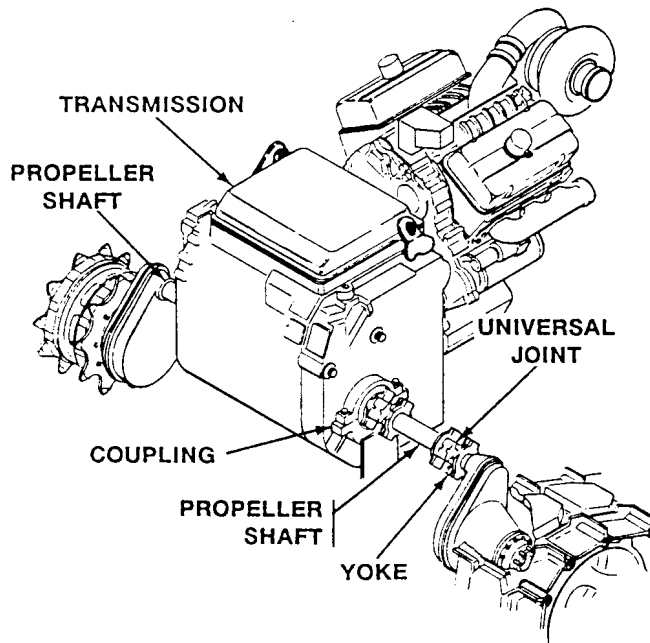

M548A3 SHOWN

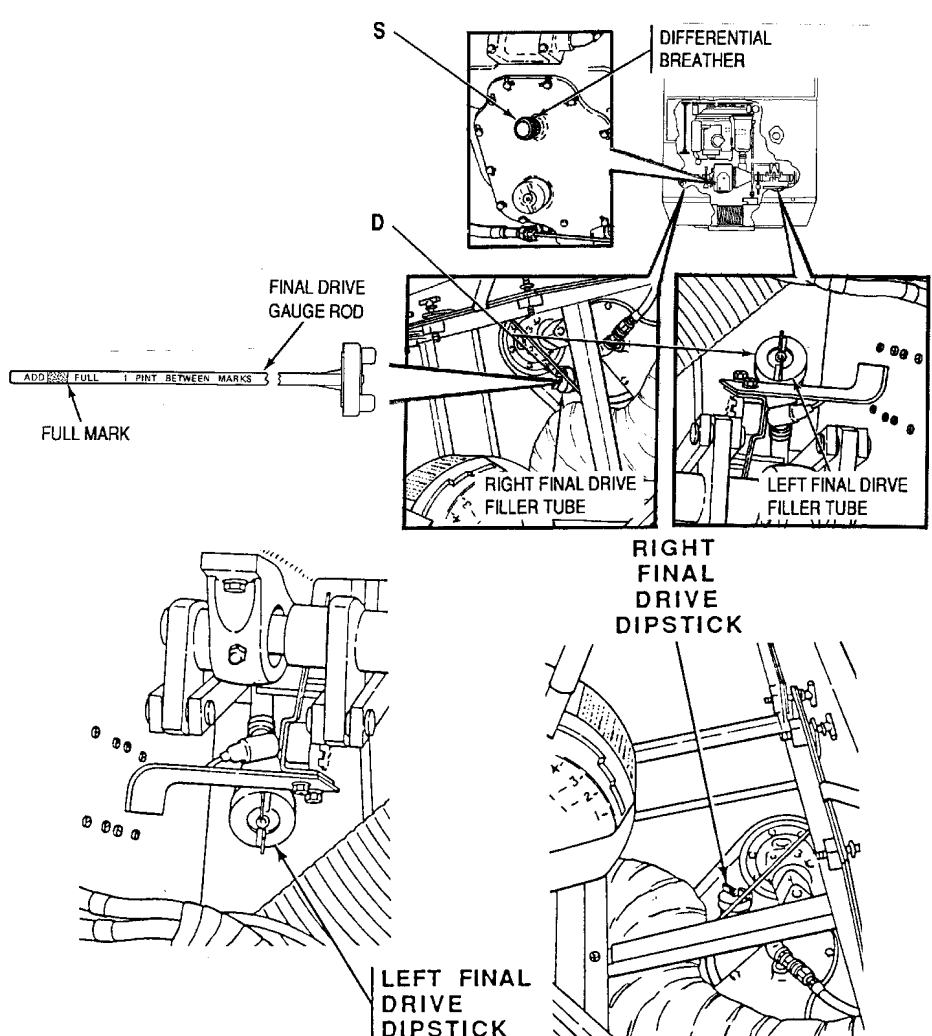
ITEM NO.	INTERVAL	MAN-HOUR	ITEM TO BE CHECKED OR SERVICED	CREWMEMBER PROCEDURE	EQUIPMENT NOT READY/ AVAILABLE IF:
37	After	0.2	Final Drive Oil	<p>DRIVER</p> <ol style="list-style-type: none"> Check the oil level of the left and right final drives. For lubricant information, see Table 8, page 0057 00-8. Oil level of the left final drive dipstick and the right final drive dipstick should be between ADD and FULL. 	Class III leak.
				c. Add oil as necessary. Do not overfill.	

PREVENTIVE MAINTENANCE CHECKS AND SERVICES — Continued

0057 00

ITEM NO.	INTERVAL	MAN-HOUR	ITEM TO BE CHECKED OR SERVICED	CREWMEMBER PROCEDURE	EQUIPMENT NOT READY/ AVAILABLE IF:
38	After		Rear Engine Compartment	<p>d. Check final drive housings for overheating.</p> <p>e. Feel final drive housing for overheating which indicates a bearing that may need service.</p> <p>f. Report any excessively hot final drive housings.</p> <p>DRIVER</p> <p>a. Remove rear access cover and grille over rear engine compartment.</p> <p>b. Inspect hydraulic, coolant, and fuel components and hoses for leaks.</p> <p>c. Report Class II and III leaks after operation.</p> <p>d. Inspect air induction hoses.</p>	<p>Any overheated final drive housing.</p> <p>Any fuel or Class III leaks.</p> <p>Any holes or tears in hoses.</p>

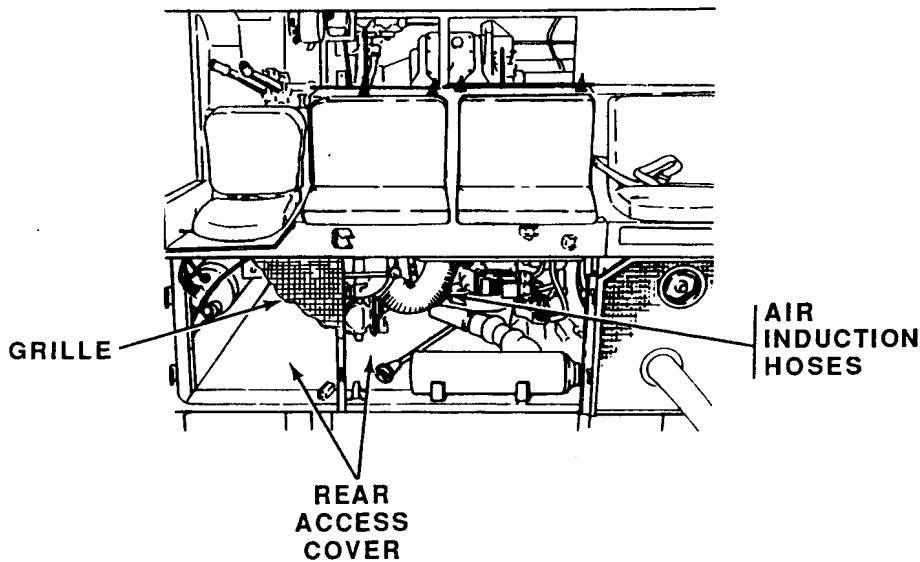

M548A1

ITEM NO.	INTERVAL	MAN-HOUR	ITEM TO BE CHECKED OR SERVICED	CREWMEMBER PROCEDURE	EQUIPMENT NOT READY/ AVAILABLE IF:
39	After		Fuel Filters (M548A1)	<p>DRIVER</p> <ol style="list-style-type: none"> Check by draining any water and deposits out of the primary and secondary fuel filters. Put a suitable container under the drain valve at the bottom of the filter. Turn MASTER SWITCH ON. Turn FUEL PUMP switch ON. Open the valve. Drain until clear fuel runs out. Dispose of waste fuel per company SOP. Turn MASTER SWITCH OFF. 	Any fuel leak.
40	After		Fuel Filters (M548A3)	<p>DRIVER</p> <p style="text-align: center;">NOTE</p> <p>Keep fuel tank as full as possible to help prevent condensation and possible contamination.</p>	

ITEM NO.	INTERVAL	MAN-HOUR	ITEM TO BE CHECKED OR SERVICED	CREWMEMBER PROCEDURE	EQUIPMENT NOT READY/ AVAILABLE IF:
				<p>a. Drain water and sediment from engine primary and secondary fuel filters as follows:</p> <ol style="list-style-type: none"> 1) Turn MASTER SWITCH ON. Turn FUEL PUMP switch ON. 2) Place a container under primary fuel filter. 3) Open drain cock to drain water and sediment from primary fuel filter. When clean fuel starts to drain out, close drain cock. 	<p>Any sign of fuel leak.</p>

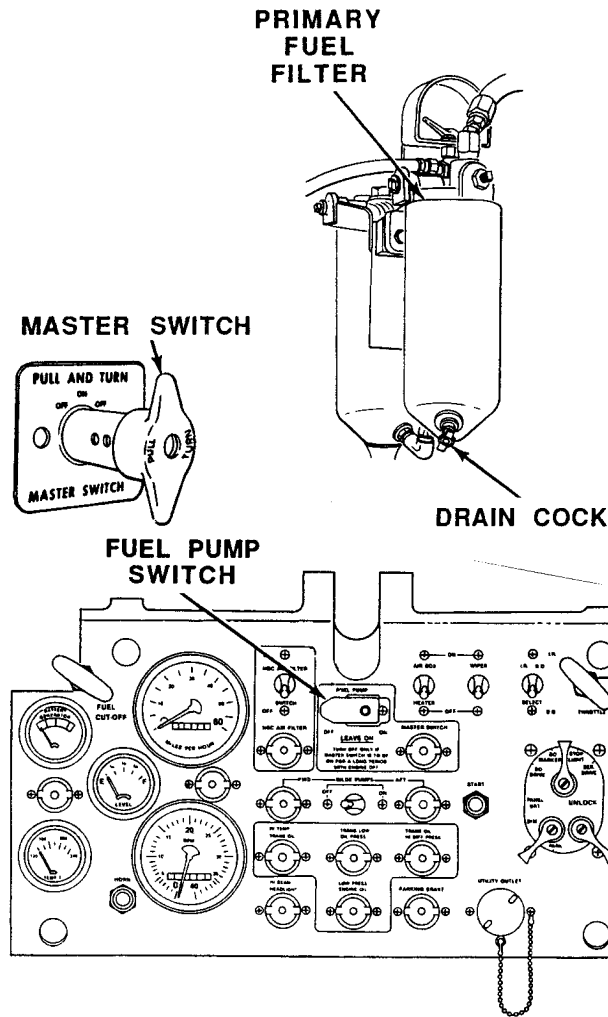

ITEM NO.	INTERVAL	MAN-HOUR	ITEM TO BE CHECKED OR SERVICED	CREWMEMBER PROCEDURE	EQUIPMENT NOT READY/ AVAILABLE IF:
				<ol style="list-style-type: none"> 4) Place a container under open end of hose. 5) Raise handle to open toggle valve and drain water and sediment from secondary fuel filter. When clean fuel starts to drain out, push handle down to close toggle valve. 6) Turn MASTER SWITCH OFF. Turn FUEL PUMP switch OFF. 7) When sediment/water is found when draining secondary fuel filter, notify unit maintenance immediately. 	<p>Any sign of fuel leak.</p>

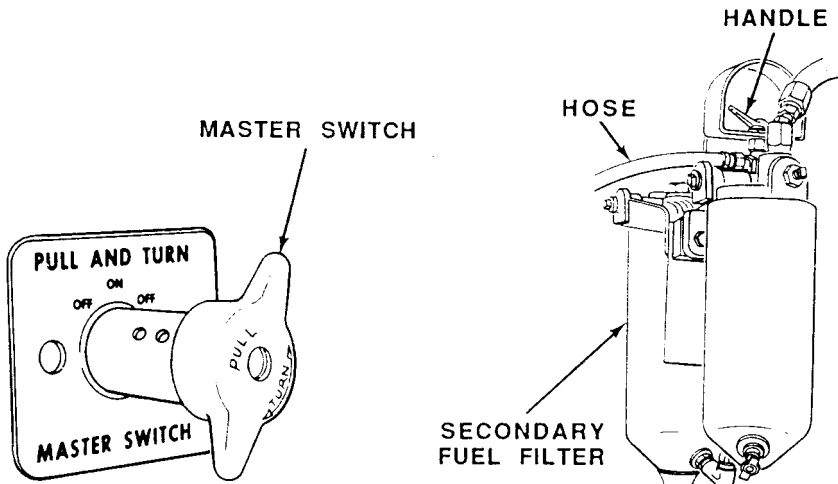

PREVENTIVE MAINTENANCE CHECKS AND SERVICES — Continued

0057 00

ITEM NO.	INTERVAL	MAN-HOUR	ITEM TO BE CHECKED OR SERVICED	CREWMEMBER PROCEDURE	EQUIPMENT NOT READY/ AVAILABLE IF:
41	After		Personnel Heater Fuel Filter Drain (M548A3)	<p>DRIVER</p> <ol style="list-style-type: none"> a. Remove front cover b. Put a suitable container under the drain valve. c. Push on the valve. d. Check that fuel is clear; drain until clear. 	Any fuel leak.

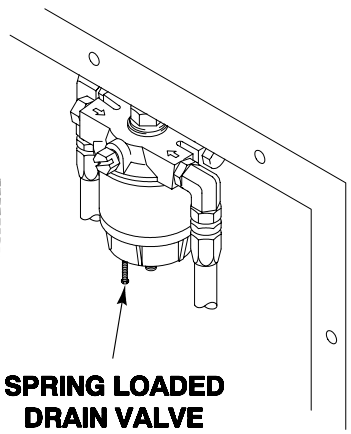
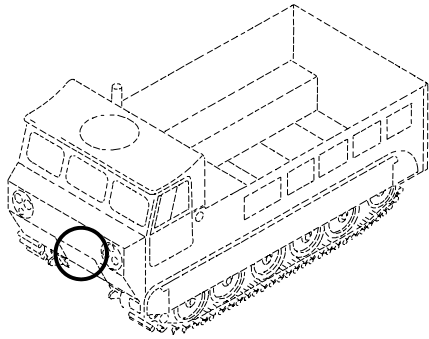

ITEM NO.	INTERVAL	MAN-HOUR	ITEM TO BE CHECKED OR SERVICED	CREWMEMBER PROCEDURE	EQUIPMENT NOT READY/ AVAILABLE IF:
42	After	0.3	Transfer Gearcase Oil (M548A1)	<p>DRIVER</p> <ol style="list-style-type: none"> a. Check oil level of the transfer gearcase. For lubricant information, see Table 6, page 0057 00-7. b. Oil level on transfer gearcase dipstick should be between ADD and FULL. c. Add oil as necessary. 	Class III leak.

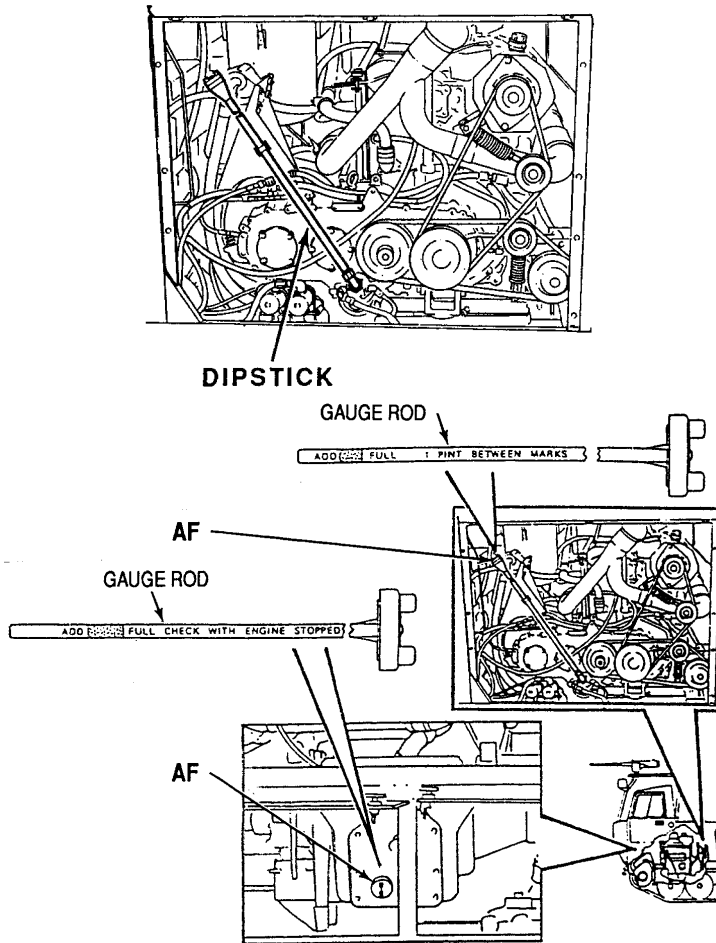

PREVENTIVE MAINTENANCE CHECKS AND SERVICES — Continued

0057 00

ITEM NO.	INTERVAL	MAN-HOUR	ITEM TO BE CHECKED OR SERVICED	CREWMEMBER PROCEDURE	EQUIPMENT NOT READY/ AVAILABLE IF:
43	After		V-Belts, Air Brake Compressor Drive Belts (Power Plant Compartment) (M548A1)	DRIVER a. Open engine compartment rear access cover. b. Check V-belts for looseness and cracks. Check idler adjustment (WP 0067 00).	One or more belt(s) missing. Fan assembly grinding or squeaking.

PREVENTIVE MAINTENANCE CHECKS AND SERVICES — Continued

0057 00

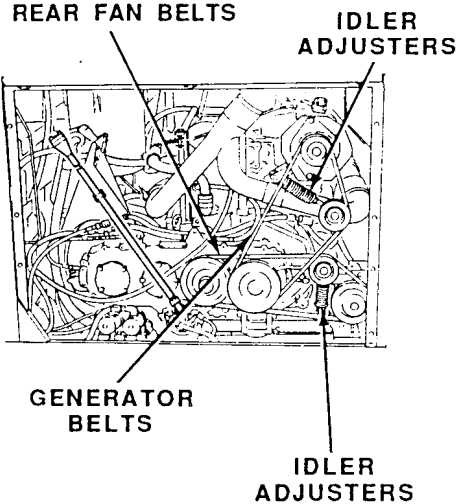
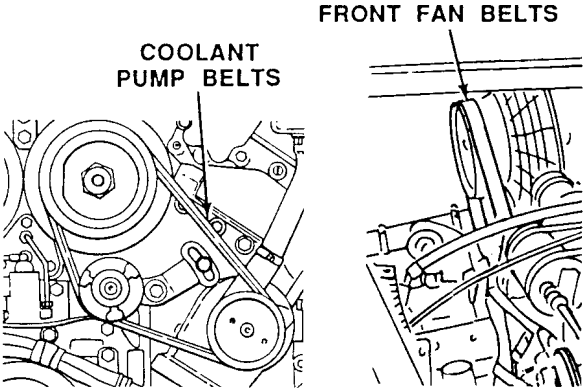
ITEM NO.	INTERVAL	MAN-HOUR	ITEM TO BE CHECKED OR SERVICED	CREWMEMBER PROCEDURE	EQUIPMENT NOT READY/ AVAILABLE IF:
				<p>c. Check generator belts, fan belts, and coolant pump belts for adjustment (WP 0067 00), dry rot, fraying, and cracks.</p> <p>d. Inspect idler adjusters for correct adjustment.</p>	<p>Any belt is missing, broken, cracks in belt fiber, has more than one crack 1/8 inch in depth (or 50% of belt thickness), or has frays more than two inches long.</p>
					
				<p>e. Check that idler adjusting rod is between the operating range marks.</p> <p>f. Inspect coolant pump belt tension by pushing on belt halfway between pulleys.</p> <p>g. Check that generator belt does not move more than about 3/8 inch.</p> <p>h. Check all pulleys for cracks, damage, or unserviceability.</p>	<p>Any pulley cracked, damaged, or unserviceable, or bolt loose or missing.</p>

PREVENTIVE MAINTENANCE CHECKS AND SERVICES — Continued

0057 00

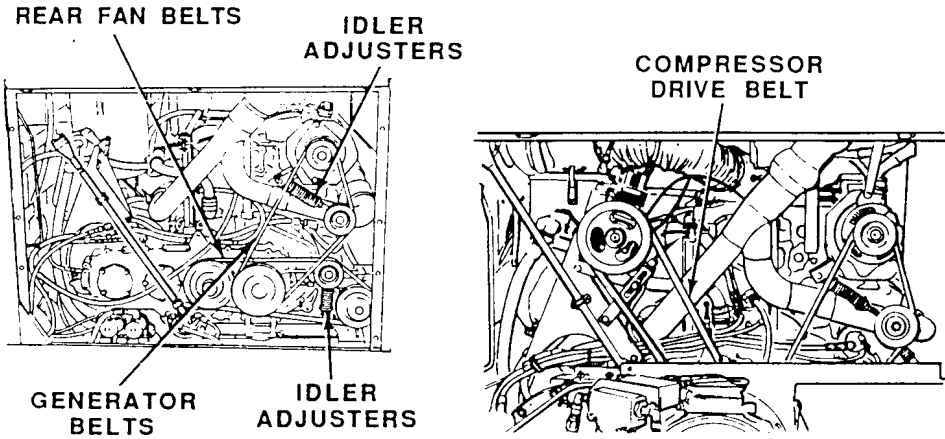
ITEM NO.	INTERVAL	MAN-HOUR	ITEM TO BE CHECKED OR SERVICED	CREWMEMBER PROCEDURE	EQUIPMENT NOT READY/AVAILABLE IF:
				<p>i. Check compressor drive belts for looseness, cracks, proper adjustment (WP 0075 00), or oil saturation.</p>	<p>One or more belts missing.</p>

PREVENTIVE MAINTENANCE CHECKS AND SERVICES — Continued

0057 00

ITEM NO.	INTERVAL	MAN-HOUR	ITEM TO BE CHECKED OR SERVICED	CREWMEMBER PROCEDURE	EQUIPMENT NOT READY/ AVAILABLE IF:
44	After		Fan Belts (Power Plant Compartment) (M548A3)	<p>DRIVER</p> <ol style="list-style-type: none"> Check fan belt, generator belt, and coolant pump belts (WP 0068 00). Inspect idler adjuster for proper adjustment (between operating range marks). Notify unit maintenance if idler is not in operating range and coolant pump belt has more than 3/8 inch deflection between pulleys. 	<p>Belt loose, frayed, or missing. Fan assembly grinding or squeaking.</p> <p>Loose or missing idler adjuster and/or hardware.</p>

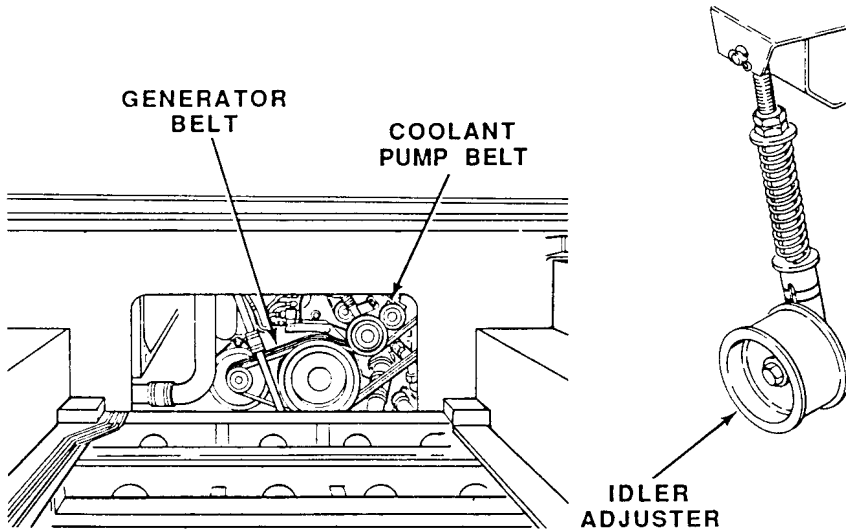

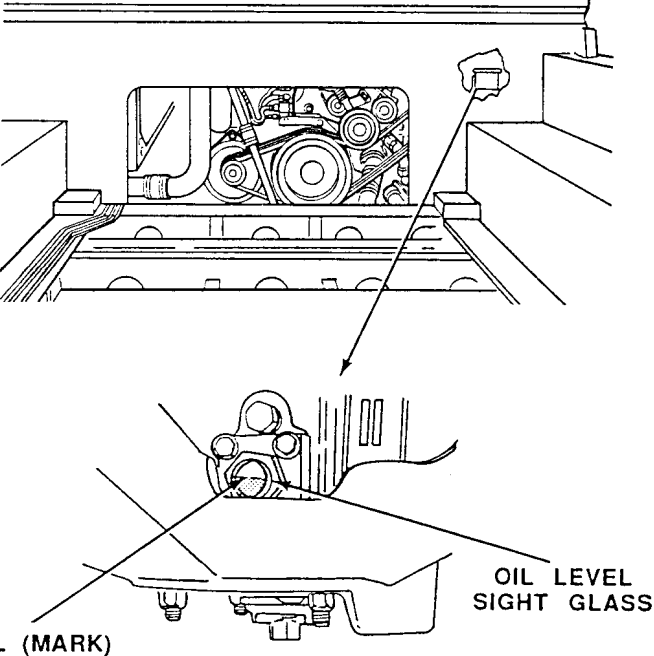
ITEM NO.	INTERVAL	MAN-HOUR	ITEM TO BE CHECKED OR SERVICED	CREWMEMBER PROCEDURE	EQUIPMENT NOT READY/ AVAILABLE IF:
45	After	0.3	Fan Gear Box (M548A3)	<p>DRIVER</p> <p>a. Check oil level in sight glass of fan gear box.</p> <p style="text-align: center;">NOTE</p> <p>Add mark is even with bottom of sight glass. Full mark is even with center of sight glass.</p> <p>b. Fan gear box oil level must be between ADD and FULL on sight glass.</p> <p>c. If low, notify unit maintenance.</p> 	Any sign of Class III leak, no sign of oil in sight glass, or oil is contaminated.

ITEM NO.	INTERVAL	MAN-HOUR	ITEM TO BE CHECKED OR SERVICED	CREWMEMBER PROCEDURE	EQUIPMENT NOT READY/ AVAILABLE IF:
46	After		Track Tension	<p>DRIVER</p> <p style="text-align: center;">WARNING</p> <div style="text-align: center;">  </div> <p>Not having the correct track tension during inspection can cause you to not see defective track parts that could cause track failure and loss of vehicle control. Soldiers can be killed or injured.</p> <p>Adjust track tension before inspecting track assembly and track shoes.</p> <p style="text-align: center;">NOTE</p> <p>Drive carrier onto hard level ground. Shift range selector to SL (for M548A3) or N (for M548A1) range and let carrier coast to stop. Do not use brakes or turn the steering wheel for the M548A3 or use the laterals on the M548A1. After carrier has stopped, shut off engine and exit carrier.</p> <p>a. Check for missing or damaged track adjusters.</p>	Track adjuster missing or unserviceable.

ITEM NO.	INTERVAL	MAN-HOUR	ITEM TO BE CHECKED OR SERVICED	CREWMEMBER PROCEDURE	EQUIPMENT NOT READY/ AVAILABLE IF:
				<p style="text-align: center;">CAUTION</p> <p>Track adjuster extended too far may buckle and become damaged during operation. Do not extend track adjuster beyond 17 in (43 cm) (maximum), as measured between centers of track adjuster and mounting screws. Adjust track after vehicle has been unloaded of equipment.</p> <p style="text-align: center;">NOTE</p> <p>Use track pin punch for measurement of track adjuster. If longer than punch, remove track shoe.</p> <p>b. Adjust track tension as necessary (T130 track) (WP 0058 00) or (T150 track) (WP 0058 01).</p>	

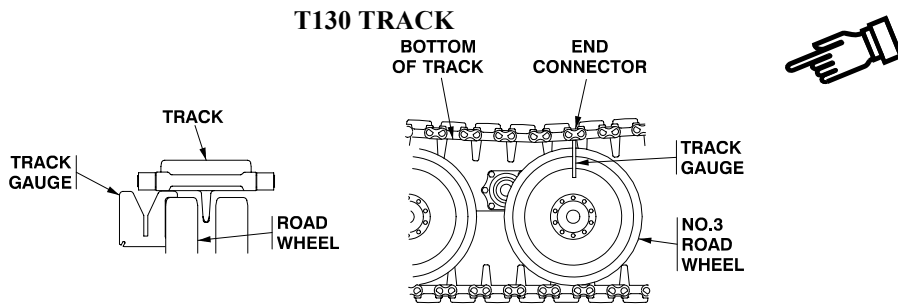
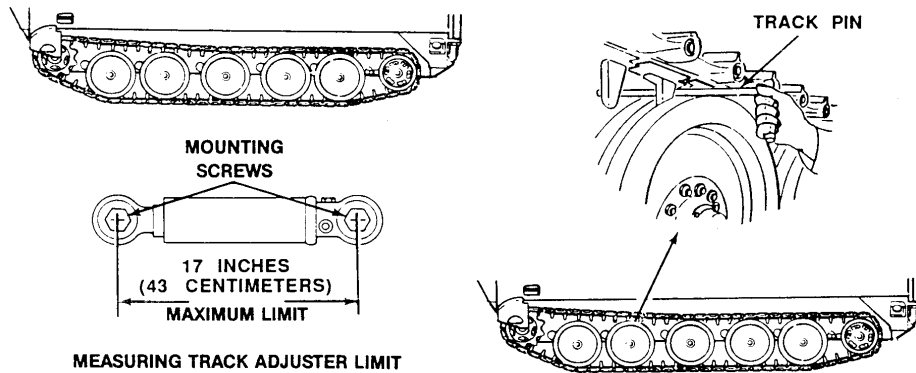

PREVENTIVE MAINTENANCE CHECKS AND SERVICES — Continued

0057 00

ITEM NO.	INTERVAL	MAN-HOUR	ITEM TO BE CHECKED OR SERVICED	CREWMEMBER PROCEDURE	EQUIPMENT NOT READY/ AVAILABLE IF:
47	After		Sprockets and Cushions	<p>DRIVER</p> <p>a. Check sprockets for cracked, broken, or missing teeth and loose or missing mounting bolts. Report cracked, broken, or missing sprocket tooth and missing mounting bolts to unit maintenance. Tighten loose mounting bolts as needed.</p>	<p>Any sprocket tooth is cracked, broken, or missing. Any sprocket to carrier mounting bolt is missing. Two or more carrier to hub mounting bolts missing.</p>

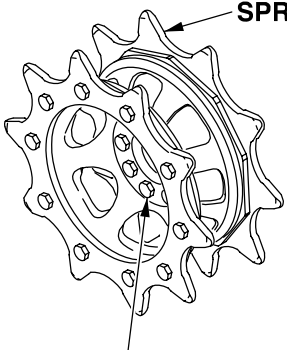
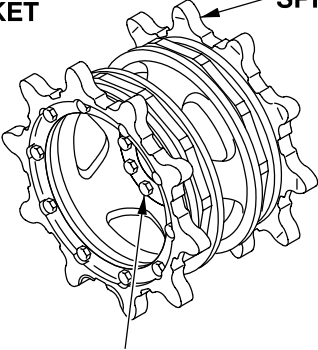
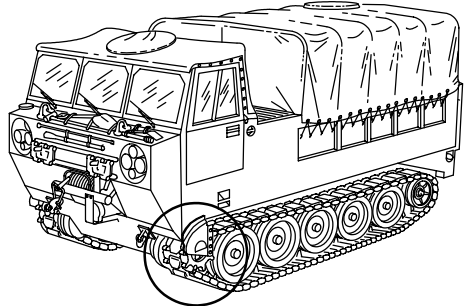
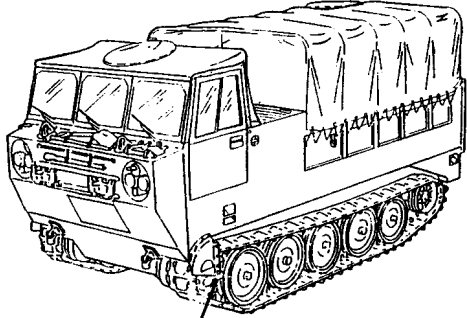
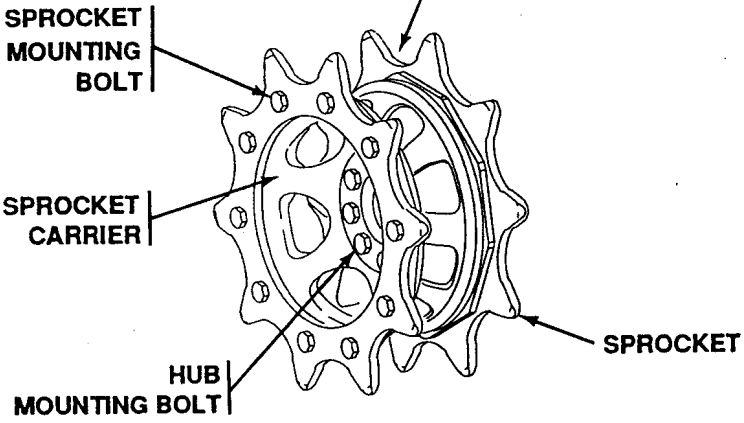
ITEM NO.	INTERVAL	MAN-HOUR	ITEM TO BE CHECKED OR SERVICED	CREWMEMBER PROCEDURE	EQUIPMENT NOT READY/ AVAILABLE IF:
			 <p>SPROCKET</p> <p>MOUNTING BOLT</p> <p>T130 TRACK</p>	 <p>SPROCKET</p> <p>MOUNTING BOLT</p> <p>T150 TRACK</p>	   <p>SPROCKET MOUNTING BOLT</p> <p>SPROCKET CARRIER</p> <p>HUB MOUNTING BOLT</p> <p>SPROCKET</p>

ITEM NO.	INTERVAL	MAN-HOUR	ITEM TO BE CHECKED OR SERVICED	CREWMEMBER PROCEDURE	EQUIPMENT NOT READY/ AVAILABLE IF:
				<p style="text-align: center;">NOTE</p> <p>New style drive sprocket will have an indented circle on one sprocket tooth, on each side of the sprocket. This is for a visible wear indicator for when to reverse the sprockets or replace the sprockets, if both sides are worn to the wear indicator. The wear indicator may not be on the same tooth for both sides. The old drive sprockets will still require the use of the profile gauge to measure the sprocket teeth wear.</p> <p>b. Check sprockets teeth for wear. Use the profile gauge on old style drive sprockets to measure sprocket teeth. If any of the sprocket tooth does not extend beyond gauge or wear indicator (on newer sprockets), notify unit maintenance.</p> <p>c. Check cushions for wear and damage. If cushions appear to be moving on sprocket hub, notify unit maintenance. If track shoes are contacting sprocket hub flange, a thumping sound will be heard. Cushions should be replaced.</p>	<p>Any sprocket tooth fails gauge test or is worn to the wear indicator.</p>

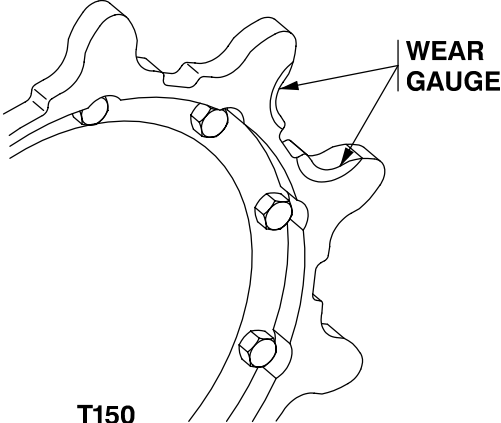
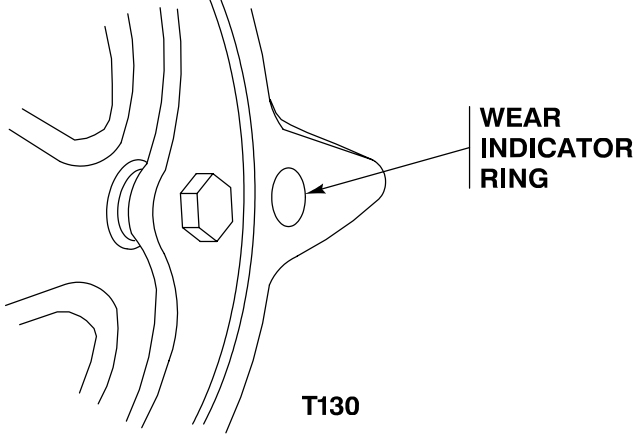
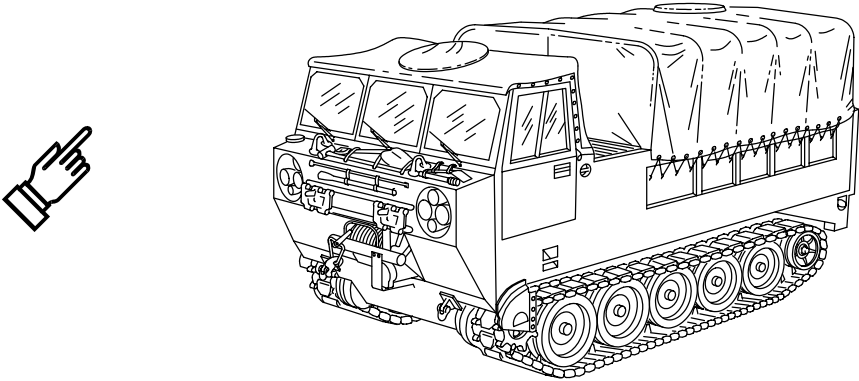
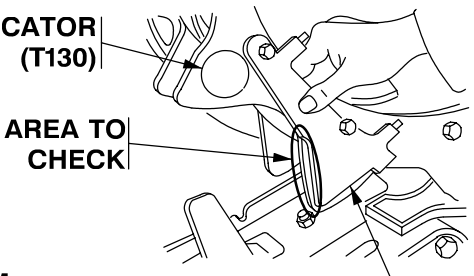
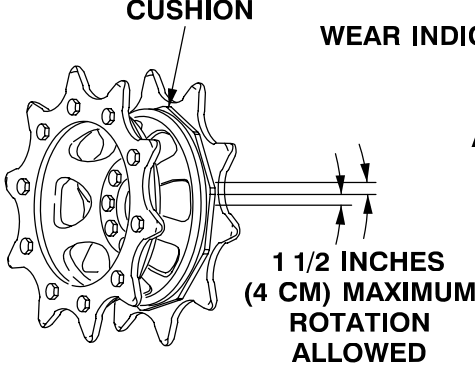
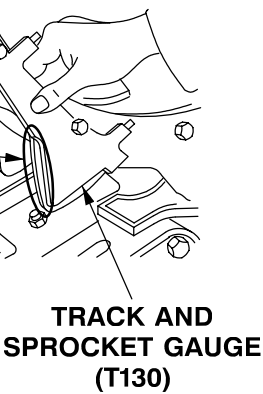
ITEM NO.	INTERVAL	MAN-HOUR	ITEM TO BE CHECKED OR SERVICED	CREWMEMBER PROCEDURE	EQUIPMENT NOT READY/ AVAILABLE IF:
			 <p>T150</p>	 <p>T130</p>	
				 <p>WEAR INDICATOR (T130)</p> <p>AREA TO CHECK</p>	
			 <p>CUSHION</p> <p>1 1/2 INCHES (4 CM) MAXIMUM ROTATION ALLOWED</p>	 <p>TRACK AND SPROCKET GAUGE (T130)</p>	

ITEM NO.	INTERVAL	MAN-HOUR	ITEM TO BE CHECKED OR SERVICED	CREWMEMBER PROCEDURE	EQUIPMENT NOT READY/ AVAILABLE IF:
48	After		Road Wheels and Idler Wheels	<p>DRIVER</p> <p style="text-align: center;">WARNING</p>  <p>Roadwheel hubs and idler wheel hubs can heat up enough to burn you.</p> <ol style="list-style-type: none"> a. Check roadwheels and idler wheels for overheating, worn mounting holes, and separation of rubber from metal. b. Check for missing, bent, or cracked roadwheels or idler wheels. 	<p>Separation of one-half of rubber contact from the hub. Chunking across one-half width of outer rubber surface.</p> <p>Missing, bent, warped, or cracked roadwheel or idler wheel. Mounting holes elongated.</p>

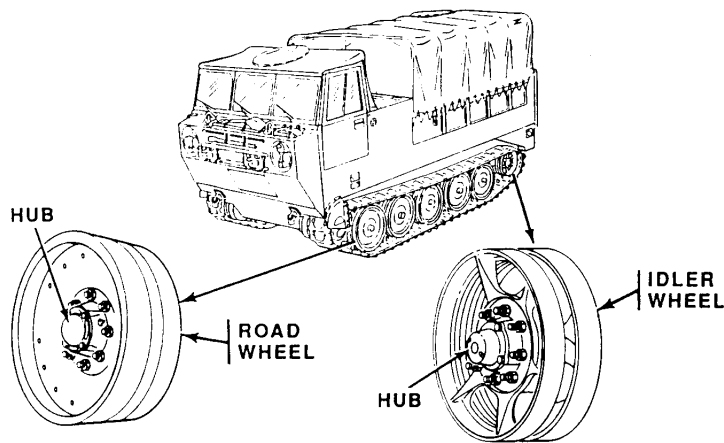

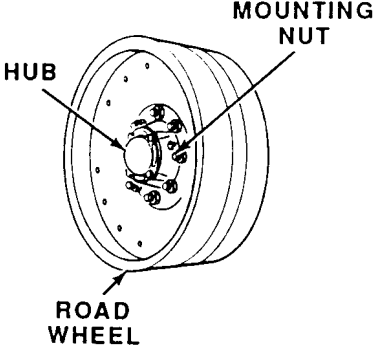
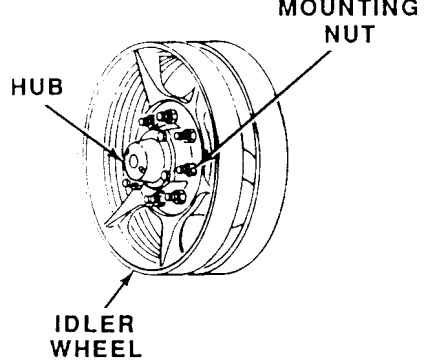
ITEM NO.	INTERVAL	MAN-HOUR	ITEM TO BE CHECKED OR SERVICED	CREWMEMBER PROCEDURE	EQUIPMENT NOT READY/ AVAILABLE IF:
				<p style="text-align: center;">NOTE</p> <p>If a hub feels hotter than any other or is hotter than normal, you may have a bearing that needs service.</p> <p>c. Feel roadwheel hubs and idler wheel hubs.</p> <p>d. Report any hub that feels hotter than others to unit maintenance.</p> <p>e. Check roadwheels and idler wheels for worn mounting holes by looking for a shiny area around mounting nuts.</p>	<p>Missing, bent, or cracked roadwheel or idler wheel. Mounting holes elongated.</p> <p>Any stud or nut loose or missing or mounting holes elongated.</p>
					
				<p>f. Check roadwheel and idler wheel hubs for lubricant leakage from around outer hub cap and between rear of hub and support arm.</p>	

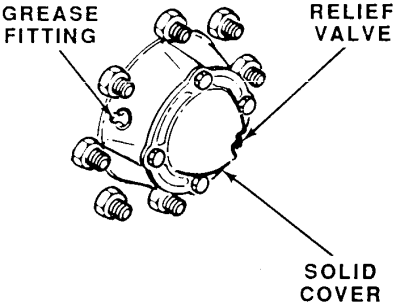
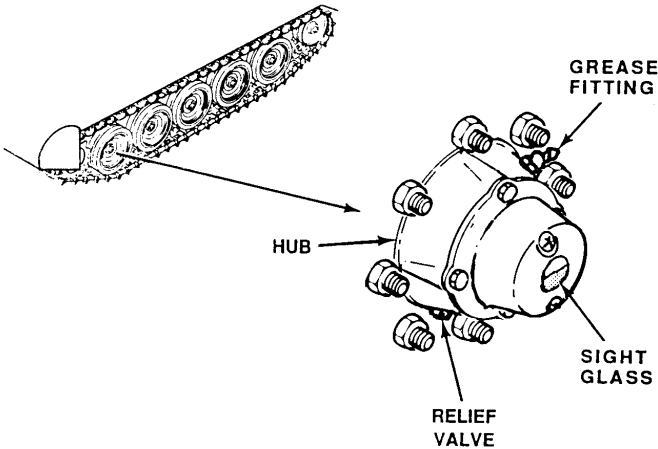
ITEM NO.	INTERVAL	MAN-HOUR	ITEM TO BE CHECKED OR SERVICED	CREWMEMBER PROCEDURE	EQUIPMENT NOT READY/ AVAILABLE IF:
				<p data-bbox="711 422 1193 548">g. Check roadwheel and idler wheel hubs by adding grease to fitting until it comes out of the pressure relief valve. Service grease-filled hubs.</p>  <p data-bbox="922 1020 1016 1052">NOTE</p> <p data-bbox="743 1089 1182 1182">If you see bubbles in the grease or if grease looks milky, there is water in it. Notify unit maintenance.</p> <p data-bbox="711 1199 1230 1352">h. The reworked hub will have a sight glass in the middle of the cover, a grease fitting, and a relief valve in the hub. Make sure glass is not broken or cracked. Service grease-filled hubs.</p> 	<p data-bbox="1252 1199 1419 1419">Cracked or broken sight glass allowing a Class III leak. Any grease fitting or relief valve missing.</p>

ITEM NO.	INTERVAL	MAN-HOUR	ITEM TO BE CHECKED OR SERVICED	CREWMEMBER PROCEDURE	EQUIPMENT NOT READY/ AVAILABLE IF:
49	After		Shock Absorbers	<p>DRIVER</p> <p style="text-align: center;">WARNING</p> <div style="text-align: center;">  </div> <p>Shock absorbers can heat up enough to burn you.</p> <p style="text-align: center;">CAUTION</p> <p>Do not perform water operations if roadwheel arm or shock absorber mounting bolts are loose or missing.</p> <p style="text-align: center;">NOTE</p> <p>Small dents in shock absorber should not affect its performance. Feel all shock absorbers after use. A cold shock is defective and should be replaced. Check for leaks. If shock is cold or has a Class III leak, notify unit maintenance.</p>	

PREVENTIVE MAINTENANCE CHECKS AND SERVICES — Continued

0057 00

ITEM NO.	INTERVAL	MAN-HOUR	ITEM TO BE CHECKED OR SERVICED	CREWMEMBER PROCEDURE	EQUIPMENT NOT READY/ AVAILABLE IF:
				<p>a. Check shock absorbers. After a good run on rough terrain or bumpy course shock absorbers should be warm enough so you can tell they have been operating properly.</p> <p>b. Check for missing or loose roadwheel arm or shock absorber mounting bolts.</p>	<p>Any shock absorber is broken or cold after operation. Any Class III leak. Any shock absorber missing.</p> <p>Any bolt loose or missing.</p>
50	After		Torsion Bars and Road Wheel Arms	<p>DRIVER</p> <p>a. Check for bent, broken, or missing road wheel arms and torsion bars. With crowbar, try to lift each road wheel. If any road wheel comes up easily, you have a broken or missing torsion bar. Notify unit maintenance of any broken or missing torsion bar.</p>	Torsion bar or road wheel arm is bent, broken, or missing.

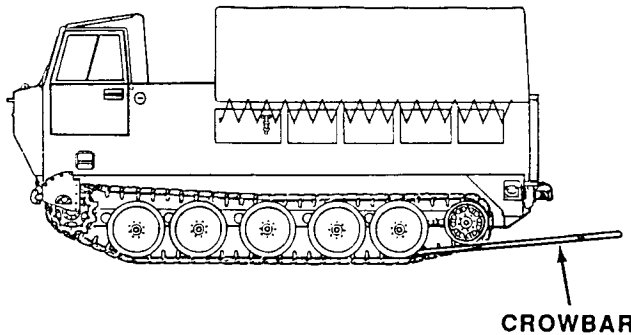
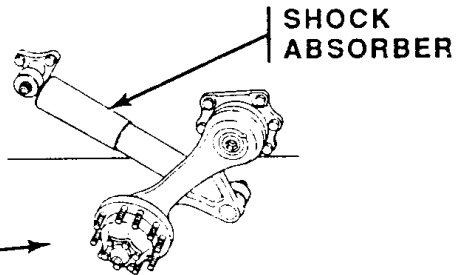
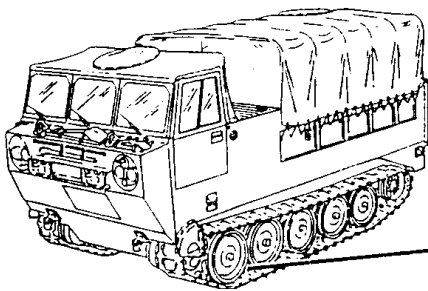

PREVENTIVE MAINTENANCE CHECKS AND SERVICES — Continued

0057 00

ITEM NO.	INTERVAL	MAN-HOUR	ITEM TO BE CHECKED OR SERVICED	CREWMEMBER PROCEDURE	EQUIPMENT NOT READY/ AVAILABLE IF:
51	After		Windshields, Windows, and Wipers	<p>b. Check that torsion bar plugs are fully seated and retaining screws are tight.</p> <p>DRIVER</p> <p>a. Check the cab windshields and side windows for cracks and breaks. Make sure they are mounted correctly. Open and close the side windows to be sure they work.</p> <div data-bbox="467 814 1328 1241" style="text-align: center;"> <p>The diagram shows a three-quarter view of a vehicle cab. Three arrows point to the windshield wiper blades, labeled 'WIPER BLADES'. Two arrows point to the front and side windshields, labeled 'WINDSHIELDS'. One arrow points to the side window, labeled 'SIDE WINDOWS'.</p> </div> <p>NOTE</p> <p>Carrier operation with inoperative windshield wipers may violate AR 385-55. Blades which are damaged or which streak badly on a clean windshield should be replaced.</p> <p>b. Check for damage, cracking, or hardening of the windshield wiper blades.</p>	

PREVENTIVE MAINTENANCE CHECKS AND SERVICES — Continued

0057 00

ITEM NO.	INTERVAL	MAN-HOUR	ITEM TO BE CHECKED OR SERVICED	CREWMEMBER PROCEDURE	EQUIPMENT NOT READY/ AVAILABLE IF:
52	After		NBC Air Filter System (M548A3)	<p>DRIVER</p> <p style="text-align: center;">NOTE</p> <p>Typically, the M548A3 will have only four NBC stations. However, M548A3 vehicles converted from M730A2 vehicles may have five NBC stations.</p> <ol style="list-style-type: none"> a. Raise spring clip up to uncover air inlet openings on the precleaner and particulate filter assembly. Turn NBC air filter switch on instrument panel to ON. Pull filtered air hose down from orifice connector assembly and check for air flow from each hose outlet. Check protective mask and microphone operation. b. Make sure spring clips are serviceable and present. Spring clips should be installed on the gas particulate filter unit (GPFU) when the GPFU is not in operation. Proper spring clip installation prevents water from damaging the filters and blower motors. c. Check hoses for tears, cracks, restrictions, dry rot, and missing or damaged connectors and hose clamps. Properly stowing the hoses after each use will help maintain your hoses in a serviceable condition. 	

PREVENTIVE MAINTENANCE CHECKS AND SERVICES — Continued

0057 00

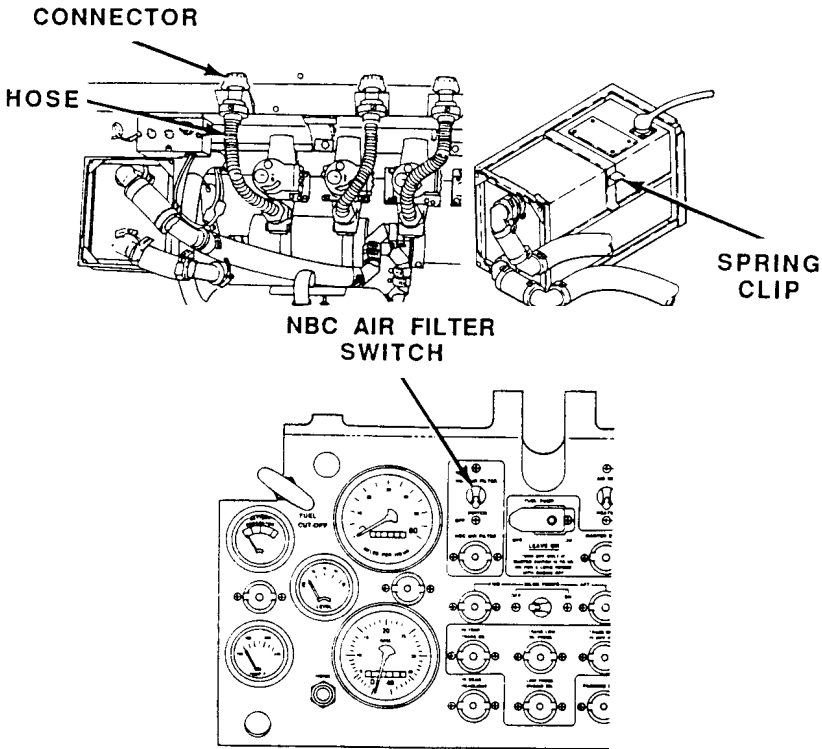
ITEM NO.	INTERVAL	MAN-HOUR	ITEM TO BE CHECKED OR SERVICED	CREWMEMBER PROCEDURE	EQUIPMENT NOT READY/ AVAILABLE IF:
			<p style="text-align: center;">CONNECTOR</p>  <p style="text-align: center;">HOSE</p> <p style="text-align: center;">NBC AIR FILTER SWITCH</p> <p style="text-align: right;">SPRING CLIP</p>		

PREVENTIVE MAINTENANCE CHECKS AND SERVICES — Continued

0057 00

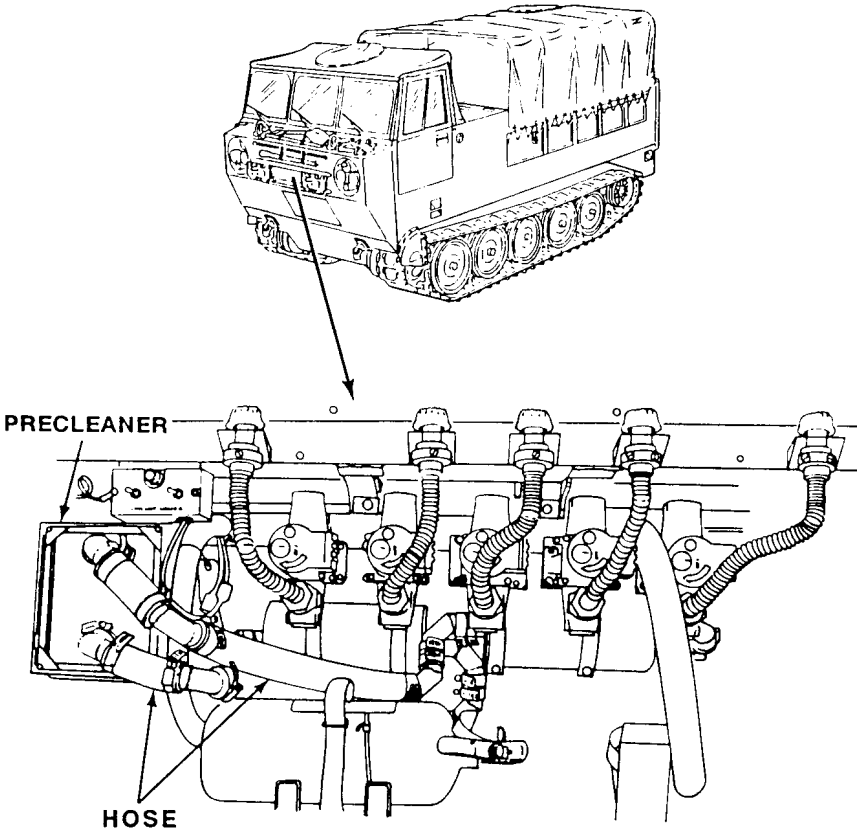
ITEM NO.	INTERVAL	MAN-HOUR	ITEM TO BE CHECKED OR SERVICED	CREWMEMBER PROCEDURE	EQUIPMENT NOT READY/ AVAILABLE IF:
				<p>d. Visually check precleaner for damage. Check air hoses for holes and tears.</p> 	

PREVENTIVE MAINTENANCE CHECKS AND SERVICES — Continued

0057 00

ITEM NO.	INTERVAL	MAN-HOUR	ITEM TO BE CHECKED OR SERVICED	CREWMEMBER PROCEDURE	EQUIPMENT NOT READY/ AVAILABLE IF:
				<p>e. Check operation of air filter indicator light: f. Raise spring clip from air intake openings on precleaner. g. Place NBC air filter switch ON. h. Check that NBC air filter indicator light comes on.</p>	

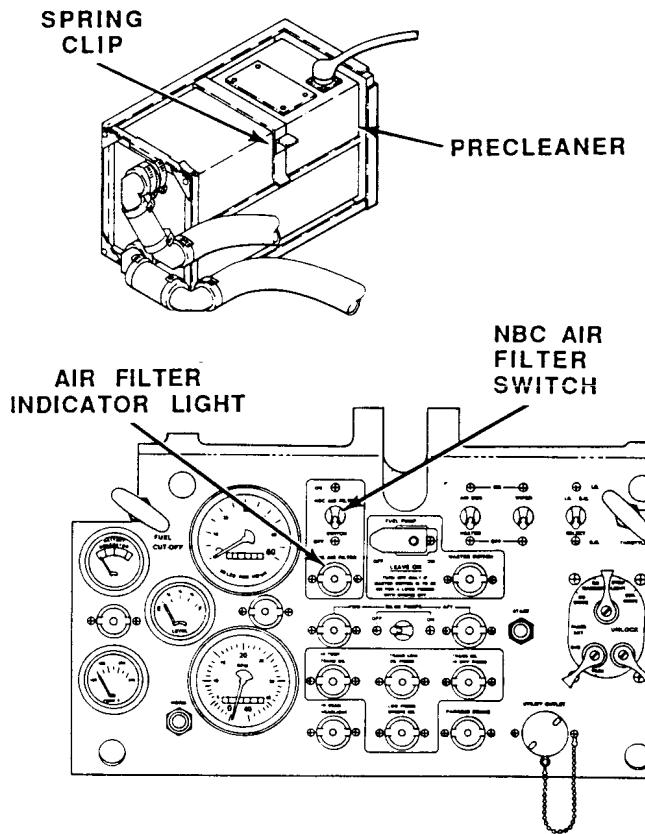

ITEM NO.	INTERVAL	MAN-HOUR	ITEM TO BE CHECKED OR SERVICED	CREWMEMBER PROCEDURE	EQUIPMENT NOT READY/ AVAILABLE IF:
53	After		NBC Air Filter System (M548A3)	<p>COMMANDER</p> <ol style="list-style-type: none"> a. Check for NBC system air flow. b. Remove air hose from orifice connector assembly at each crew member station. c. Check for steady flow of air at each hose outlet. d. Check NBC heater indicator light. e. Turn heater control knob at each crew member station to the right. Check that indicator light at each member station comes on. f. Check for heated air. 	

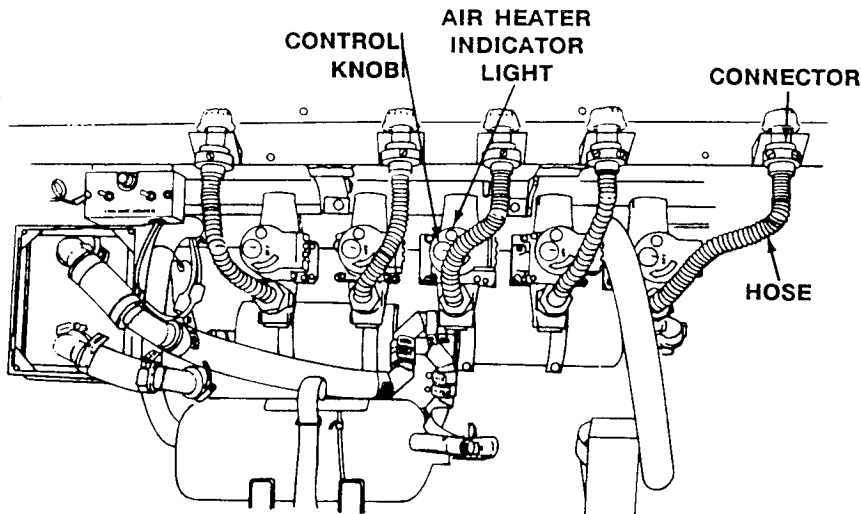

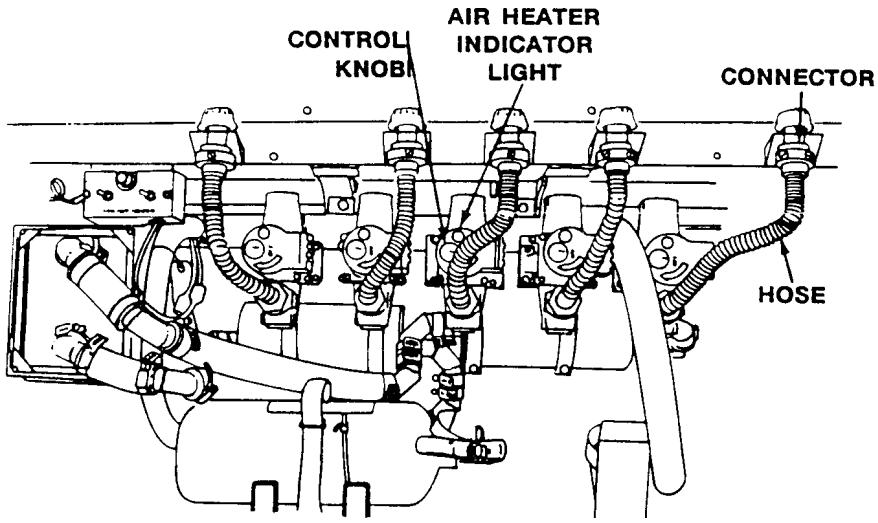
ITEM NO.	INTERVAL	MAN-HOUR	ITEM TO BE CHECKED OR SERVICED	CREWMEMBER PROCEDURE	EQUIPMENT NOT READY/ AVAILABLE IF:
				<p style="text-align: center;">NOTE</p> <p>It takes fifteen minutes for air flow to reach maximum temperature.</p> <p>g. Check for increase in temperature of air flow at each hose outlet. Turn heater control knob at each crew member station to OFF.</p> <p>h. Install air hose on orifice connector assembly at each crew member station.</p> <div style="text-align: center;">  <p>The diagram shows a control panel with five stations. From left to right, each station has a control knob, an indicator light, and a hose connector. A label 'CONTROL KNOB' points to the first knob, 'AIR HEATER INDICATOR LIGHT' points to the second light, and 'CONNECTOR' points to the third connector. A 'HOSE' is shown connected to the fourth connector. The panel is mounted on a structure with various mechanical components and wiring visible.</p> </div>	

ITEM NO.	INTERVAL	MAN-HOUR	ITEM TO BE CHECKED OR SERVICED	CREWMEMBER PROCEDURE	EQUIPMENT NOT READY/ AVAILABLE IF:
54	After		NBC Air Filter System (M548A3)	<p>DRIVER</p> <ol style="list-style-type: none"> a. Check NBC air filter indicator light. b. Press spring clip down over air intake openings on precleaner. c. Place NBC air filter switch to OFF. Check that indicator light goes off. 	

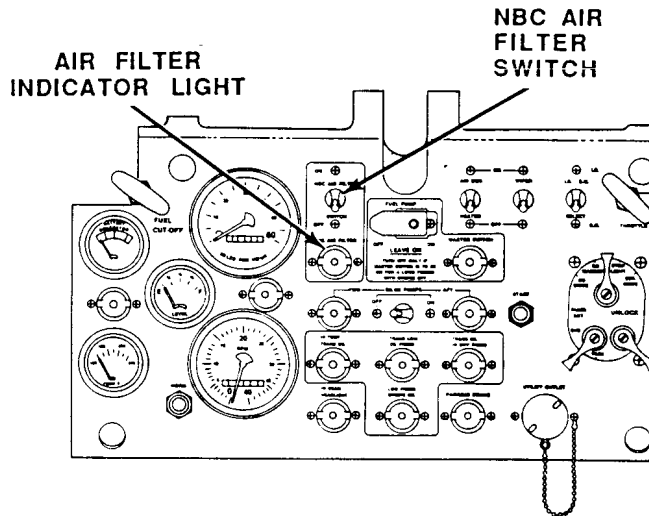
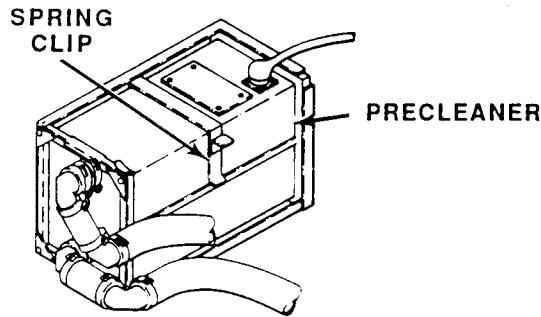
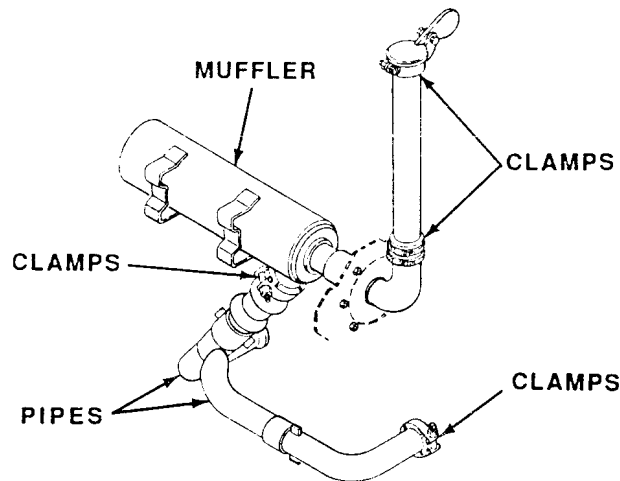

Table 19. Preventive Maintenance Checks and Services for M548A1/M548A3, Weekly

ITEM NO.	INTERVAL	MAN-HOUR	ITEM TO BE CHECKED OR SERVICED	CREWMEMBER PROCEDURE	EQUIPMENT NOT READY/ AVAILABLE IF:
55	Weekly		Exhaust Pipes and Muffler (M548A1)	<p style="text-align: center;">NOTE</p> <p>The exhaust system emits carbon particles when cold; however, as the system heats up, the pipe joints expand and seal, allowing minimal carbon emissions.</p> <ol style="list-style-type: none"> a. Check all visible components of the exhaust system, pipes, muffler, and clamps. b. Check for deterioration, damage, or weld failures. c. Check for loose or missing hardware. 	Exhaust system is damaged or any part is missing, improperly aligned, or insecurely mounted.





PREVENTIVE MAINTENANCE CHECKS AND SERVICES — Continued

0057 00

ITEM NO.	INTERVAL	MAN-HOUR	ITEM TO BE CHECKED OR SERVICED	CREWMEMBER PROCEDURE	EQUIPMENT NOT READY/ AVAILABLE IF:
56	Weekly		Exhaust System, Engine (M548A3)	<p style="text-align: center;">NOTE</p> <p>The exhaust system emits carbon particles when cold; however, as the system heats up, the pipe joints expand and seal, allowing minimal carbon emissions.</p> <ol style="list-style-type: none"> a. Inspect all visible components of the exhaust system. b. Check for deterioration, damage, or weld failures. c. Check for loose or missing hardware. d. Notify unit maintenance of any defects. 	Any part is missing, damaged, improperly aligned, or insecurely mounted.

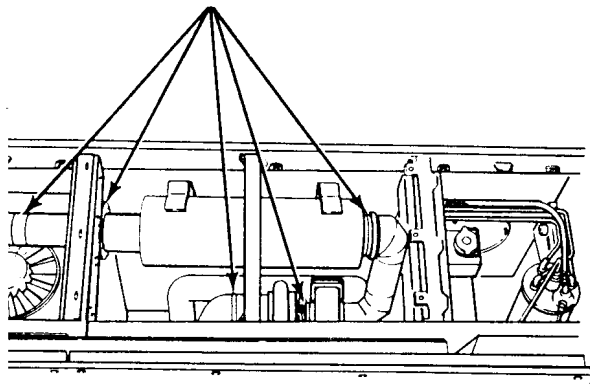
CONNECTION POINTS (CLAMPS)

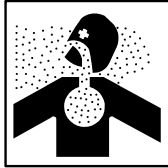

ITEM NO.	INTERVAL	MAN-HOUR	ITEM TO BE CHECKED OR SERVICED	CREWMEMBER PROCEDURE	EQUIPMENT NOT READY/ AVAILABLE IF:
57	Weekly		Air Cleaner Element	<p style="text-align: center;">WARNING</p> <div style="display: flex; justify-content: space-around;">   </div> <p>If NBC exposure is suspected, all air filter media should be handled by personnel wearing protective equipment. Consult your unit NBC officer or NBC NCO for appropriate handling instructions.</p> <p style="text-align: center;">CAUTION</p> <p>Do not drop or rap filter element when cleaning it. Two non-interchangeable air cleaner types are used. Make sure you reinstall the right element and container.</p> <p style="text-align: center;">NOTE</p> <p>The M548A3 air cleaner element should not be removed unless directed by unit maintenance when cleaning is required. Otherwise, damage may occur to the air cleaner elements's supports and then non-filtered air will go through to the engine, causing damage to the piston cylinders.</p>	

PREVENTIVE MAINTENANCE CHECKS AND SERVICES — Continued

0057 00

ITEM NO.	INTERVAL	MAN-HOUR	ITEM TO BE CHECKED OR SERVICED	CREWMEMBER PROCEDURE	EQUIPMENT NOT READY/ AVAILABLE IF:
58	Weekly		Air Cleaner (M548A3)	<p>a. Service the air cleaner weekly.</p> <p>b. Remove air cleaner container with the element inside.</p> <p>c. Take out element.</p> <p>d. Clean and reinstall element.</p> <p>e. Install container with element inside.</p> <p>f. Check air cleaner restriction indicator.</p> <div data-bbox="532 1087 1055 1480" data-label="Image"> </div> <p style="text-align: center;">WARNING</p> <p>Do not service air cleaner or vent system after NBC attack until carrier has been decontaminated. Before doing this task, read NBC warnings (WP 0053 00).</p>	<p>Container, latches, or element is missing, damaged, or broken. Gasket torn or separated from filter element.</p> <p>Hose or indicator is cracked or unserviceable.</p>

ITEM NO.	INTERVAL	MAN-HOUR	ITEM TO BE CHECKED OR SERVICED	CREWMEMBER PROCEDURE	EQUIPMENT NOT READY/ AVAILABLE IF:
				<p style="text-align: center;"><u>CAUTION</u></p> <p>Do not operate carrier if air cleaner element is missing or door gasket is missing or damaged. Extensive engine damage will result.</p> <p>During steam cleaning of carrier, do not allow water to enter air cleaner system. Engine oil can be contaminated.</p> <ol style="list-style-type: none"> a. Check air cleaner as follows: b. Remove door. c. Check door for missing or damaged seals and latch works. d. Ensure air cleaner element is present. e. Notify unit maintenance if air cleaner element needs servicing. 	Air cleaner element, door, or gasket is missing or damaged.

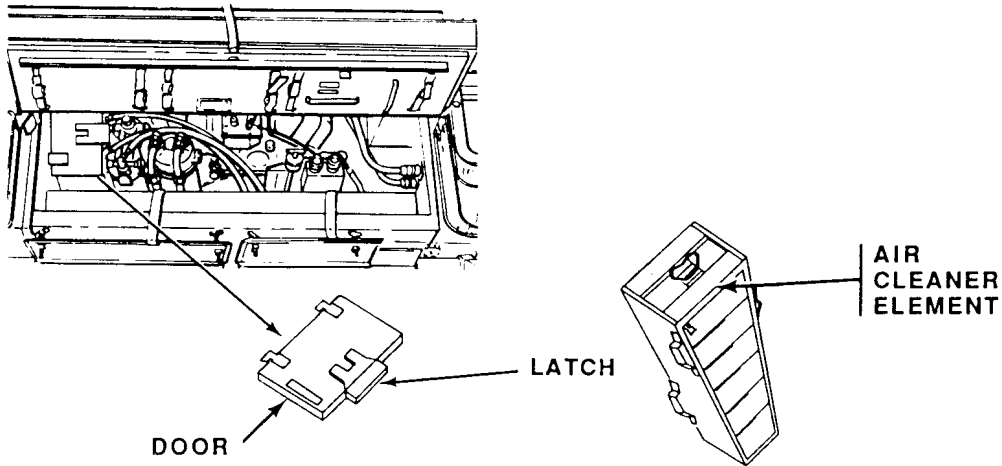

ITEM NO.	INTERVAL	MAN-HOUR	ITEM TO BE CHECKED OR SERVICED	CREWMEMBER PROCEDURE	EQUIPMENT NOT READY/ AVAILABLE IF:
59	Weekly		Lights	<p>a. Check the driving lights by turning the main light switch on. Make sure the headlights work on high and low beam.</p> <p>b. Check high beam indicator light and instrument panel lights to see if they are working.</p>	Any inoperable lights, cracked or missing lens, or broken hardware.
<p>M548A1</p>					
<p style="text-align: center;">WARNING</p>					
<p>Do not look directly into infrared lights. You may damage your eyes.</p>					
<p>c. Check infrared lights on both high and low beam by holding your hand over lens. If light is working, you will feel heat.</p> <p>d. Check if your carrier is equipped with turn signals. See if signal works on both sides of carrier.</p>					

PREVENTIVE MAINTENANCE CHECKS AND SERVICES — Continued

0057 00

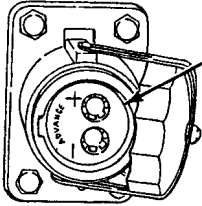
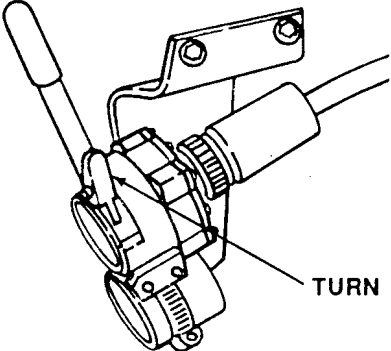
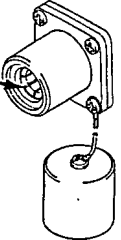
ITEM NO.	INTERVAL	MAN-HOUR	ITEM TO BE CHECKED OR SERVICED	CREWMEMBER PROCEDURE	EQUIPMENT NOT READY/ AVAILABLE IF:
60	Weekly		Slave Cable Receptacle  <p>M548A1</p>	 <p>TURN SIGNALS</p> <p>e. Check stoplight-taillight operation. f. Stoplight-taillight should light when headlights are turned on. g. Make sure stoplight-taillight brightens during carrier braking. h. Check blackout drive, marker, and stoplights.</p> <p>a. Check the slave receptacle for damage and corrosion.</p>  <p>SLAVE RECEPTACLE</p> <p>M548A3</p>	

PREVENTIVE MAINTENANCE CHECKS AND SERVICES — Continued

0057 00

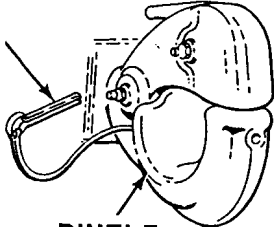
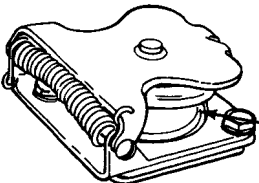
ITEM NO.	INTERVAL	MAN-HOUR	ITEM TO BE CHECKED OR SERVICED	CREWMEMBER PROCEDURE	EQUIPMENT NOT READY/ AVAILABLE IF:
61	Weekly		Towing Pintle and Trailer Receptacle	<p>a. Check the pintle and locking pin to be sure nothing is missing or broken. Twist the pintle twice to see that it doesn't bind.</p> <div data-bbox="737 554 1203 800" style="text-align: center;">  <p>LOCKING PIN</p> <p>PINTLE</p> </div> <p>b. Check the trailer light receptacle to see if it is broken or corroded.</p> <div data-bbox="513 961 1073 1142" style="text-align: center;">  <p>TRAILER LIGHT RECEPTACLE</p> </div>	
62	Weekly		Cab Doors, Cargo Compartment Door, and Tailgate	<p>a. Open and close cab doors, cargo compartment door, and tailgate. Check that latches and hinges hold doors and tailgate tightly shut by opening and closing cab doors, cargo compartment door, and tailgate.</p> <p style="text-align: center;">NOTE</p> <p>A seal that is brittle, cracked, broken, or obviously not sealing is no good.</p> <p>b. Notify unit maintenance of bad seals.</p> <p>c. Check cab door seals, cargo door seals, and tailgate seal.</p>	Cargo door will not secure tightly. Tailgate will not secure tightly.

PREVENTIVE MAINTENANCE CHECKS AND SERVICES — Continued

0057 00

ITEM NO.	INTERVAL	MAN-HOUR	ITEM TO BE CHECKED OR SERVICED	CREWMEMBER PROCEDURE	EQUIPMENT NOT READY/ AVAILABLE IF:
63	Weekly		Engine Airbox Drain (M548A1)	<p>a. Check the airbox drain can and plastic element.</p> <p>b. Remove the airbox drain can.</p> <p style="text-align: center;">NOTE</p> <p>Dispose of waste fuel per local SOP.</p> <p>c. Dump waste fuel and the element out of the can.</p> <p>d. Clean the can and element with cleaning compound. Put the element in the can and install can on engine.</p>	Airbox can missing.

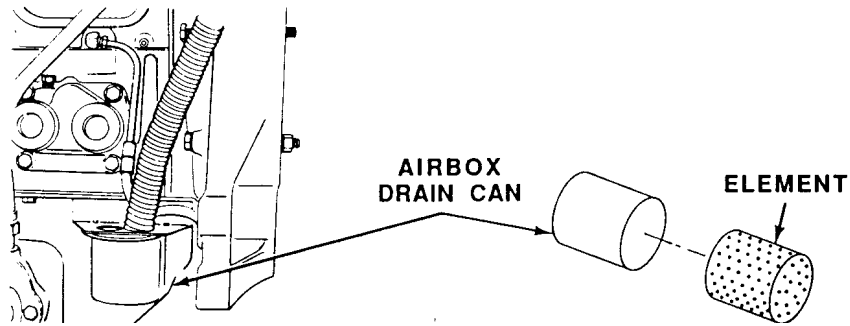

ITEM NO.	INTERVAL	MAN-HOUR	ITEM TO BE CHECKED OR SERVICED	CREWMEMBER PROCEDURE	EQUIPMENT NOT READY/ AVAILABLE IF:
64	Weekly		Front Bilge Pump	<ol style="list-style-type: none"> Check operation of front bilge pump. Turn on the master switch and bilge pump switch. Check that the front bilge pump light comes on. Feel at the bilge pump outlet for a stream of water, if water is in the bilge. 	Bilge pump inoperable.

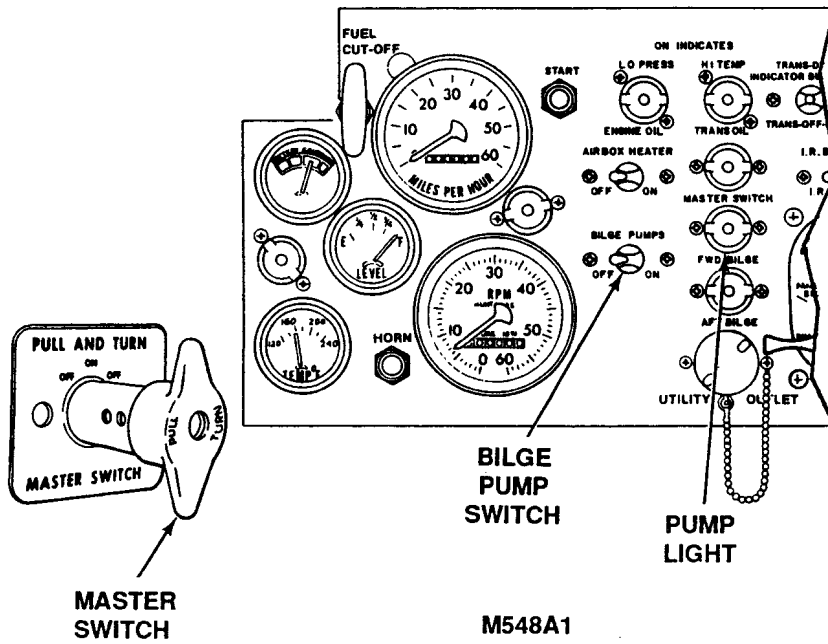

M548A1

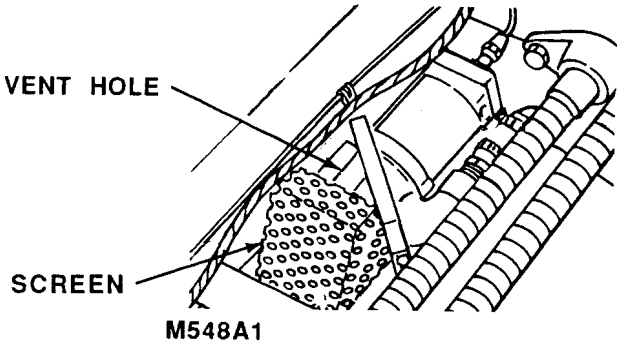
ITEM NO.	INTERVAL	MAN-HOUR	ITEM TO BE CHECKED OR SERVICED	CREWMEMBER PROCEDURE	EQUIPMENT NOT READY/ AVAILABLE IF:
				<p style="text-align: center;">WARNING</p> <div style="text-align: center;">  </div> <p>Touching your bare hands or tools to the starter terminals on the starter, or electrical leads when accessing through the bottom access cover, may cause death or serious injury. Do not touch any electrical leads or terminals on the starter because there is 24 volts with over 200 amps connected directly from the batteries.</p> <p style="text-align: center;">NOTE</p> <p>Access for the front bilge pump on M548A1 is through the center floor plates. Access on the M548A3 is through the bottom hull access cover.</p> <p>e. Check the screen that protects the bilge pump intake. Keep screen and vent hole clean.</p> <div style="text-align: center;">  </div>	

ITEM NO.	INTERVAL	MAN-HOUR	ITEM TO BE CHECKED OR SERVICED	CREWMEMBER PROCEDURE	EQUIPMENT NOT READY/ AVAILABLE IF:
65	Weekly		Batteries	<p style="text-align: center;"><u>CAUTION</u></p> <p>In cold weather, the batteries must be charged immediately after adding water so the water will combine with electrolyte and not freeze.</p> <p style="text-align: center;"><u>NOTE</u></p> <p>The M548A3 has a second set of batteries on the right side under the passenger seat.</p> <ol style="list-style-type: none"> a. Check that the electrolyte is at the right level and batteries are in good shape. b. Take off caps and make sure the electrolyte is at the right level. Fill with distilled water if the level is low. c. Check that cables and terminals are clean and the connections are tight. d. Check that the hold down clamps and retainers are tight. 	<p>Batteries unserviceable.</p> <p>Any terminal or cable damaged or loose.</p> <p>Damage to retainers or missing clamps and retainers.</p>

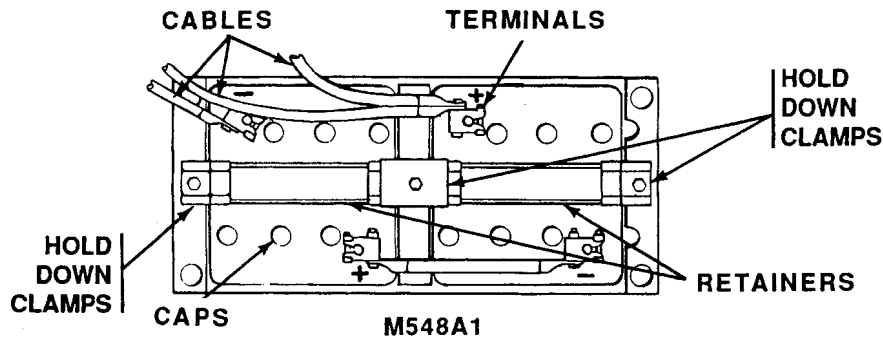

PREVENTIVE MAINTENANCE CHECKS AND SERVICES — Continued

0057 00

ITEM NO.	INTERVAL	MAN-HOUR	ITEM TO BE CHECKED OR SERVICED	CREWMEMBER PROCEDURE	EQUIPMENT NOT READY/ AVAILABLE IF:
66	Weekly		Cab Cover and Cargo Compartment Cover	<p>e. Check that vent holes in caps are clear before installing caps.</p> <p>f. Check battery casing and post for damage and signs of corrosion.</p> <div data-bbox="548 621 1224 995" data-label="Diagram"> <p>The diagram shows a top-down view of a battery bank. It features two rows of terminals and posts. Labels with arrows point to 'TERMINALS POSTS' on the left, 'BATTERY CAP' on the right, and 'CABLES' at the bottom. The battery bank is labeled 'M548A3 SHOWN DRIVER'S SIDE'.</p> </div> <p>a. Check the cab cover and the cargo compartment cover.</p> <p>b. Check that covers are in good shape and installed right.</p> <p>c. Inspect the hatches.</p> <p>d. If covers are dirty or mildewed, you should wash, scrub, and dry them.</p> <p>e. Inspect tiedown ropes.</p> <p>f. Replace badly frayed rope.</p>	<p>Damage to battery casing or posts.</p>

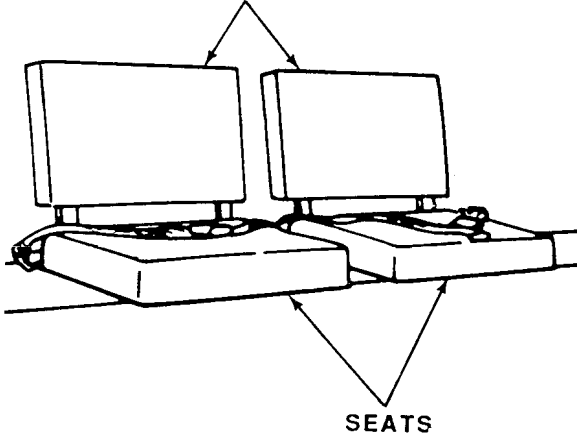
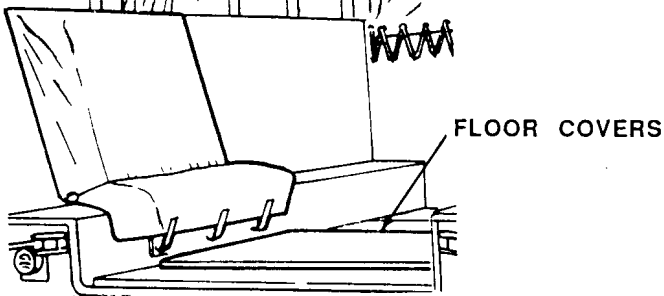
ITEM NO.	INTERVAL	MAN-HOUR	ITEM TO BE CHECKED OR SERVICED	CREWMEMBER PROCEDURE	EQUIPMENT NOT READY/ AVAILABLE IF:
67	Weekly		Cab, Personnel Seats and Belts	<p style="text-align: center;">NOTE</p> <p>Carrier operation with inoperative seat belts may violate AR 385-55.</p> <ol style="list-style-type: none"> a. Check seats and backrests for holes or tears. b. Check seat belts for rips, tears, or holes. c. Check seat pins/mount bolts. <div style="text-align: center;"> <p>BACKRESTS</p>  <p>SEATS</p> </div>	
68	Weekly		Floor Covers	<ol style="list-style-type: none"> a. Make sure the floor covers are in good shape and securely mounted. <div style="text-align: center;">  <p>FLOOR COVERS</p> </div>	

PREVENTIVE MAINTENANCE CHECKS AND SERVICES — Continued

0057 00

ITEM NO.	INTERVAL	MAN-HOUR	ITEM TO BE CHECKED OR SERVICED	CREWMEMBER PROCEDURE	EQUIPMENT NOT READY/ AVAILABLE IF:
69	Weekly		Insulated Cargo Cover and Thermal Windows	<ol style="list-style-type: none"> a. Check the cargo cover for holes or tears, ties, or buckles. b. Make sure the hatch cover is OK and snug on its mounting ring. c. See that the thermal windows are clear, secure, and not damaged. 	

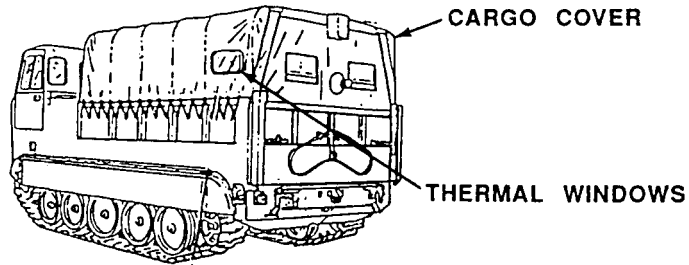

INSPECT/ADJUST T130 TRACK TENSION

0058 00

THIS WORK PACKAGE COVERS:

Inspection (page 0058 00-1).
 Adjustment (page 0058 00-5).

INITIAL SETUP:

Maintenance Level

Operator

Materials/Parts

Wiping rag (WP 0083 00, Item 16)

Tools and Special Tools

Drive Pin Punch (WP 0081 00, Item 32)
 Grease Gun (WP 0081 00, Item 22)
 Open End Wrench, 5/8 inch (WP 0081 00, Item 41)
 Profile Gauge (WP 0081 00, Item 21)

Personnel Required

Driver

Equipment Condition

Engine stopped (WP 0023 00 or WP 0024 00)

INSPECTION

WARNING



Not having the correct track tension during inspection can cause you to not see defective track parts that could cause track failure and loss of vehicle control. Soldiers can be killed or injured.

Adjust track tension before inspecting track assembly and track shoes.

1. Measure the height of the top edge of the grouser above the bushing housing. If grouser height left is less than 1/4 inch (0.6 cm), replace shoe (WP 0060 00).

NOTE

Always keep a set of good track pads on the rear bumper.

2. Measure the height of the top of the track shoe pad above the top of the grouser. If height is less than 1/16 inch (0.15 cm), the pad is too worn for that shoe. If the shoe is otherwise OK, the pad must be replaced because it will damage a paved road (WP 0061 00).

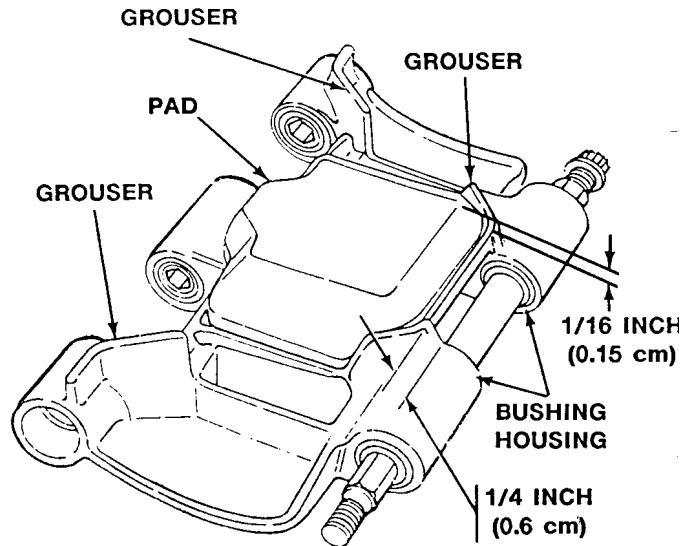

NOTE

Measure track shoe wear with track installed and under normal tension.

3. Measure track shoe bushing wear by inserting two pins of profile gauge into the bushing housings of two track shoes. If the pins can be inserted at the shortest distance, the bushings are OK. If the pins don't line up with housings see task: Remove/Install Track Shoe (WP 0060 00).
4. Start engine (WP 0013 00 or WP 0014 00).
5. Drive carrier slowly to firm level ground (WP 0020 00 or WP 0021 00).

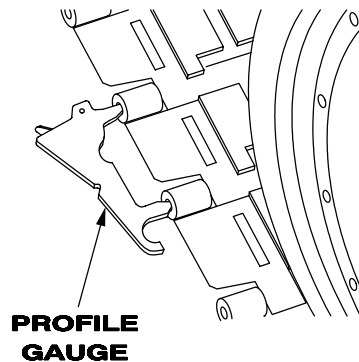
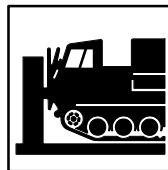
**WARNING**

Loss of control at speeds above 5 mph (8 kph) could cause vehicle to crash. Do not shift to SL (Steering Lock) position at speeds above 5 mph (8 kph).

NOTE

Perform Step 6 if operating an M548A3. Perform Step 7 if operating an M548A1.

6. Let carrier coast to a stop. Do not use steering wheel or press brake pedal to stop carrier. Place transmission controller in SL (Steering Lock) position to coast to a stop.
7. Let carrier coast to a stop. Do not use laterals or pivot brakes to stop carrier. Place transmission in N (neutral) position to coast to a stop.
8. Stop engine (WP 0023 00 or WP 0024 00).

NOTE

Either drive pin punch or profile gauge may be used to check track tension. If using drive pin punch, do Steps 9 - 10. If using profile gauge, do Steps 11 - 12.

9. Check track tension by using drive pin punch. Insert drive pin punch between top of number two road wheel and bottom of track. If drive pin punch can be inserted freely and track touches top of number three road wheel, track tension is correct.
10. If drive pin punch cannot be inserted freely, track tension is too loose. To tighten track tension, do ADJUSTMENT Step 1. If drive pin punch can be inserted freely, but track does not touch top of number three road wheel, track tension is too tight. To loosen track tension, do ADJUSTMENT Step 2.

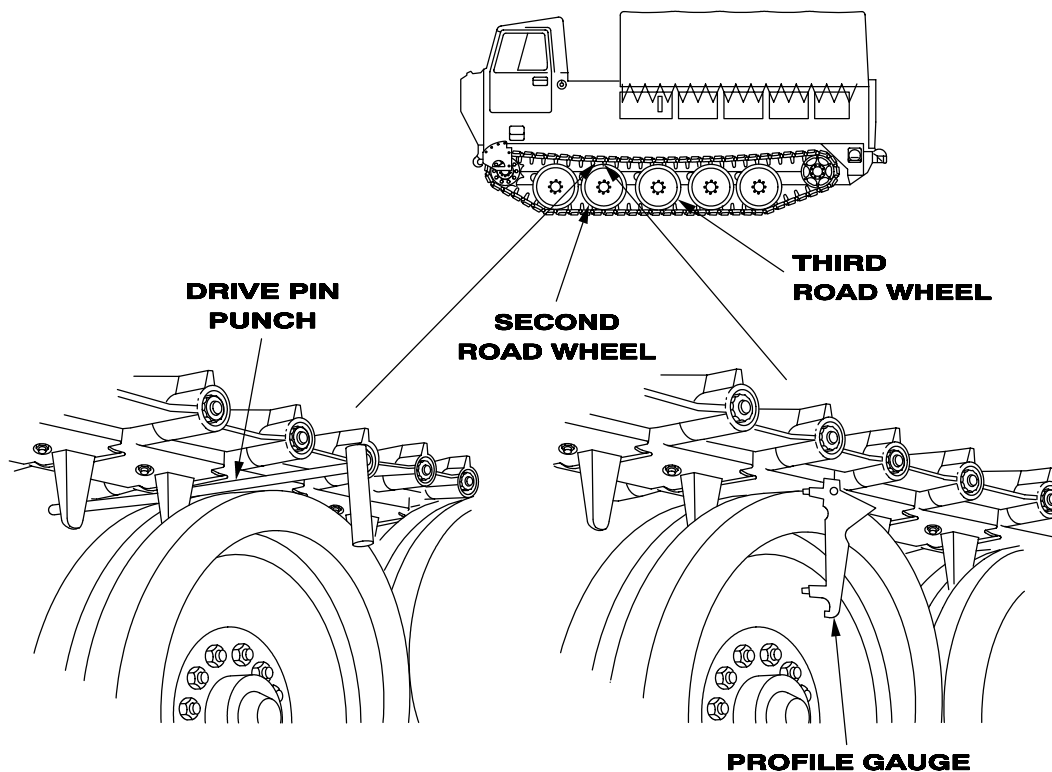

11. Check track tension by using profile gauge. Position gauge lightly against bottom of track at centerline of second road wheel. Look through hole in gauge. If top of second road wheel can be seen (3/8 to 5/8 inch (1 to 1.6 cm)) and track touches number three road wheel, track tension is correct.
12. If top of second road wheel can't be seen or track does not touch third road wheel, track needs adjusting. To tighten track tension, do ADJUSTMENT Step 1. To loosen track tension, do ADJUSTMENT Step 2.

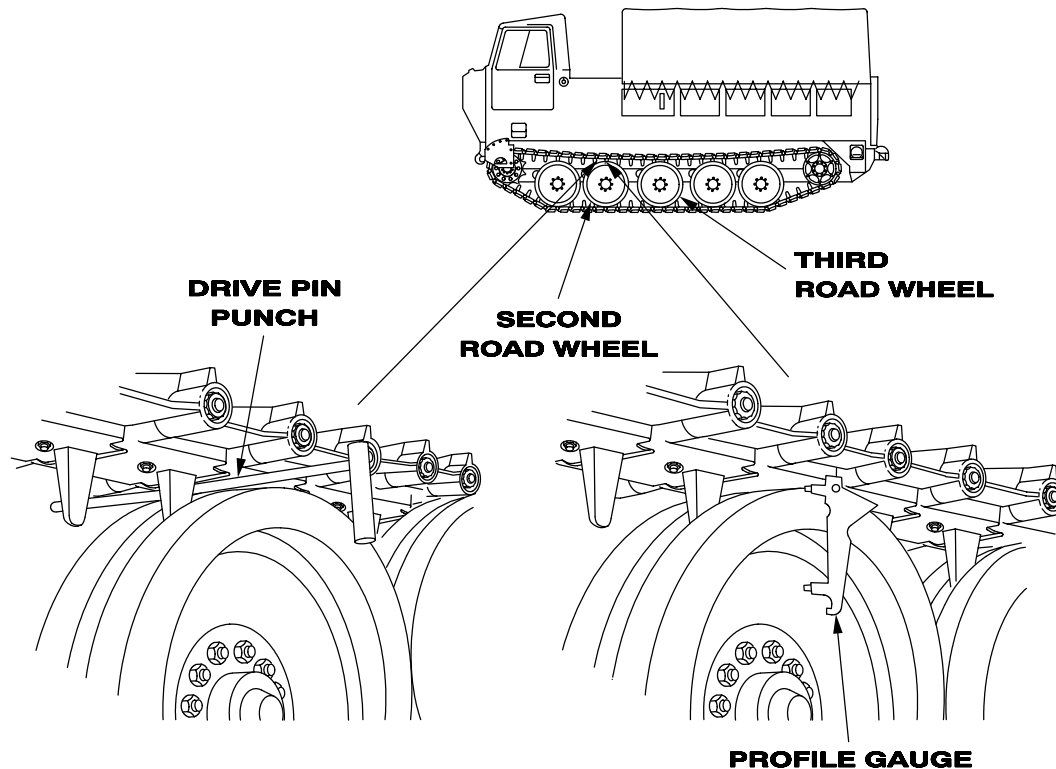

ADJUSTMENT

CAUTION

Dirt can damage fitting and cylinder. Clean all dirt from fitting on track tension adjuster.

Servicing the fitting can damage the track adjuster, idler wheel, and final drive bearings. Track adjuster fitting is not a true lubrication point. **DO NOT** service when lubricating the carrier.

Track adjuster can be damaged during carrier operation. Do not extend adjuster beyond 17 inches (43 cm).

1. Tighten track tension using grease gun to add grease through fitting on track tension adjuster. If track adjuster is extended to its maximum limit of 17 inches and the track is still too loose, remove one track shoe (WP 0060 00).

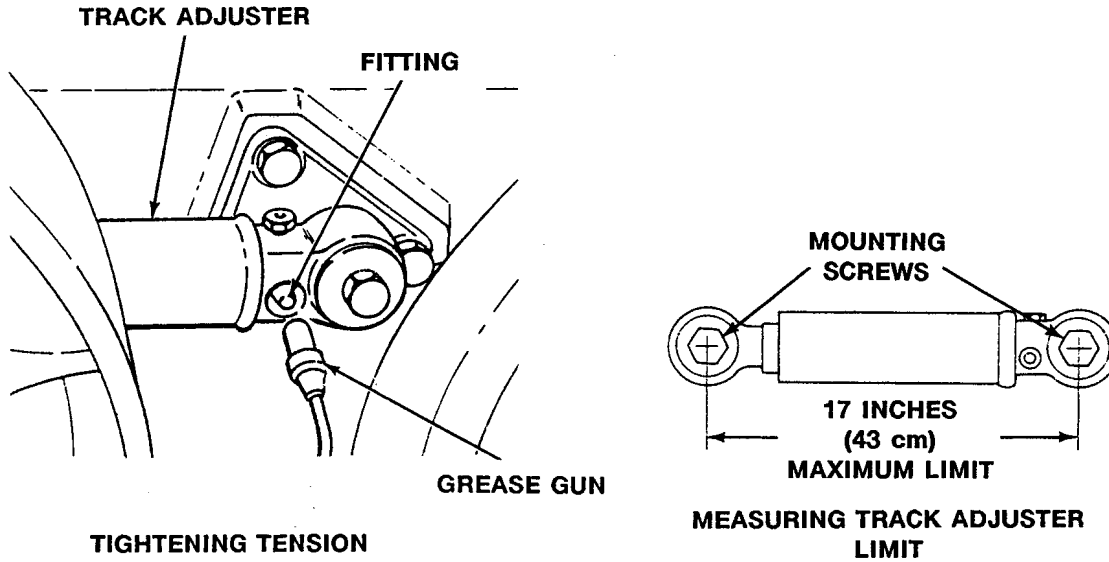

2. Loosen track tension by slowly opening bleed valve on track tension adjuster to let grease out. Wipe up excess grease. Use 5/8 inch open end wrench and wiping rag. If track adjuster is in as far as it will go, and track is still too tight, add one track shoe (WP 0060 00). Check track tension. See INSPECTION Steps 9-12.

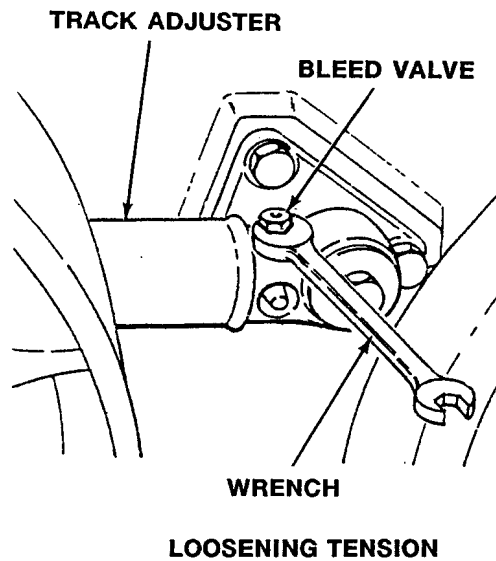

END OF TASK

ADJUST T150 TRACK TENSION

0058 01**THIS WORK PACKAGE COVERS:**

Adjust Track Tension (page 0058 01-1).

INITIAL SETUP:Maintenance Level

Operator

Personnel Required

Driver

Tools and Special Tools

Grease Gun (WP 0081 00, Item 22)

Open End Wrench, 5/8 inch (WP 0081 00, Item 41)

Track Gauge (WP 0081 00, Item 21A)

Equipment Condition

Engine stopped (WP 0023 00 or WP 0024 00)

Materials/Parts

Wiping rag (WP 0083 00, Item 16)

ADJUSTMENT

1. Start engine (WP 0013 00 or WP 0014 00).
2. Drive carrier slowly to firm level ground (WP 0020 00 or WP 0021 00).

WARNING

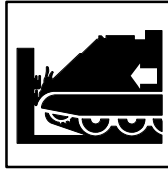

Do not shift to SL (Steering Lock) position at speeds above 5 mph. Loss of control at speeds above 5 mph could cause vehicle to crash.

NOTE

Tension needs to be adjusted after mission when vehicle is completely unloaded of equipment and before mission after vehicle has been fully loaded.

NOTE

Perform Step 3 if operating an M548A3. Perform Step 4 if operating an M548A1.

3. Let carrier coast to a stop. Do not use steering wheel or press brake pedal to stop carrier. Place transmission controller in PV (Pivot) position to coast to a stop
4. Let carrier coast to a stop. Do not use laterals or pivot brakes to stop carrier. Place transmission in N (neutral) position to coast to a stop.
5. Stop engine (WP 0023 00 or WP 0024 00).
6. Block track
7. To check track tension, position track tension gauge lightly between bottom of track and the third road wheel. Gauge should fit between bottom of track and top of road wheel.

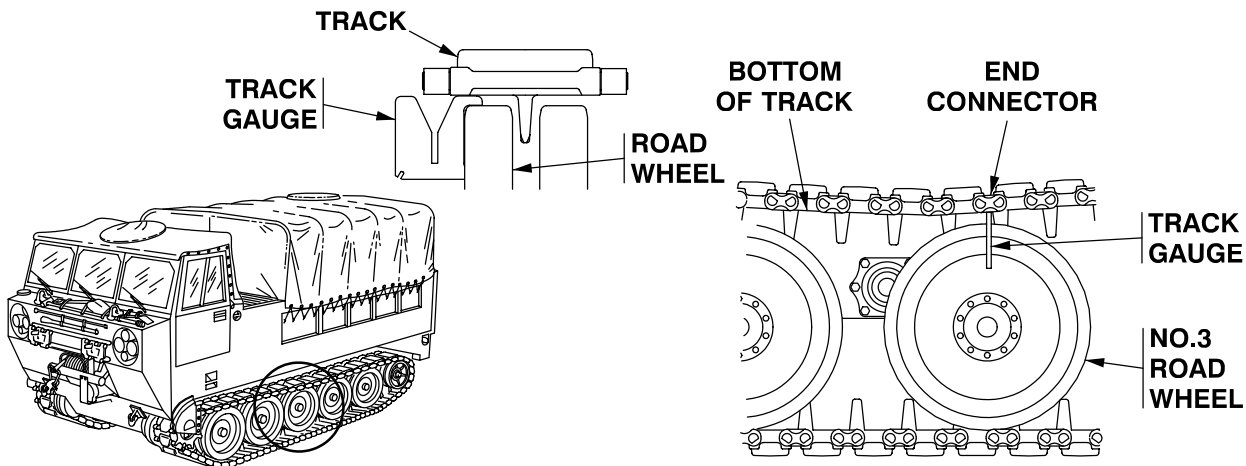

8. If gauge does not fit between bottom of track and top of road wheel, track tension is too loose; if gauge fits between track and road wheel, but is not touching both at the same time, track tension is too tight. To tighten track tension, go to Step 9. To loosen track tension, go to Step 10.

CAUTION

Dirt can damage fitting and cylinder. Clean all dirt from fittings on track tension adjuster. Servicing the fitting can damage the track adjuster, idler wheel, and final drive bearings. Track adjuster fitting is not a true lubrication point. Do not service when lubricating the carrier.

9. To tighten track tension, add grease through fitting on track adjuster. If track adjuster is extended to its maximum limit of 17 inches (43 centimeters) and the track is still loose, remove one track shoe (WP 0060 01) and readjust track tension (Steps 6 □ 10) □

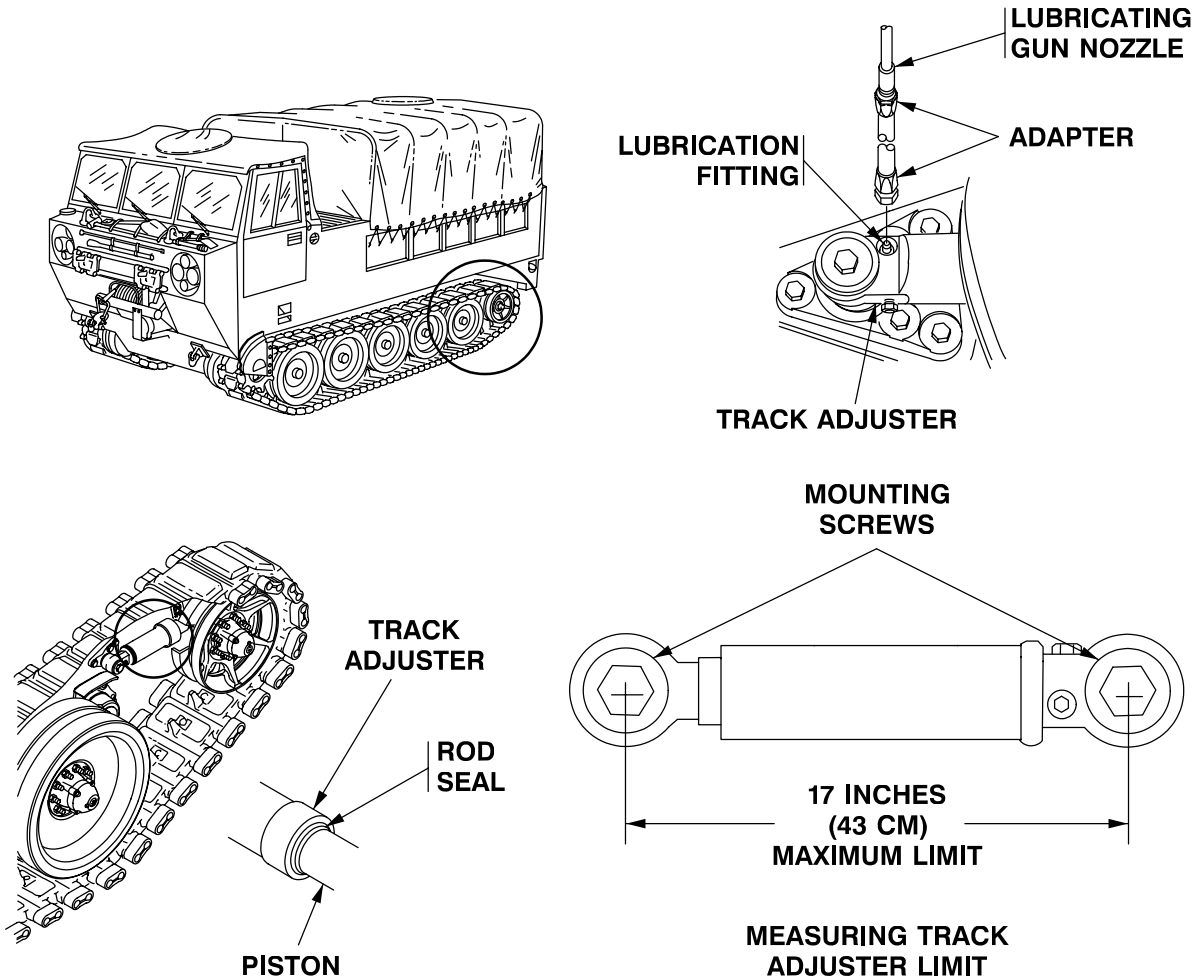

10. To loosen track tension, slowly open bleed valve on track tension adjuster to let grease out. Wipe up excess grease. Use 5/8 inch open end wrench and wiping rag. If track adjuster is in as far as it will go, and track is still too tight, add one track shoe (WP 0060 01) and readjust track tension (Steps 6 - 10).

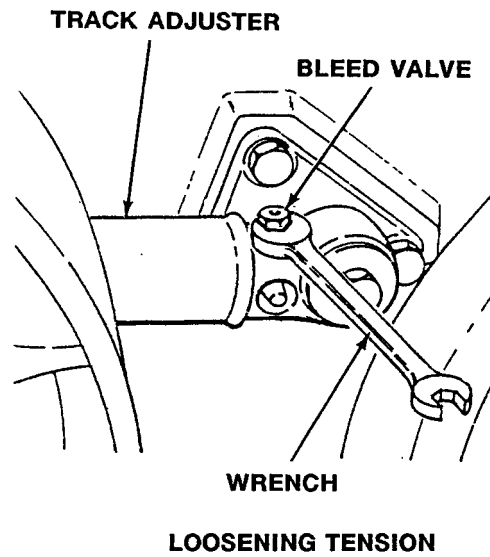

END OF TASK

BREAK/JOIN T130 TRACK

0059 00

THIS WORK PACKAGE COVERS:

- Break (page 0059 00-1).
- Join (page 0059 00-6).

INITIAL SETUP:

Maintenance Level

Operator

Personnel Required

- Driver
- Crew

Tools and Special Tools

- Adjustable Wrench (WP 0081 00, Item 43)
- Crowbar (WP 0081 00, Item 12)
- Drive Pin Punch (WP 0081 00, Item 32)
- Grease Gun (WP 0081 00, Item 22)
- Hammer, 2 lb (WP 0081 00, Item 24)
- Industrial Goggles (WP 0082 00)
- Socket Wrench Handle (WP 0081 00, Item 27)
- Socket Wrench, 11/16 inch (WP 0081 00, Item 38)
- Track Fixtures (WP 0081 00, Item 19)

Equipment Condition

Engine stopped (WP 0023 00 or WP 0024 00)

BREAK

1. Unstow crowbar, track fixtures, and hammer.

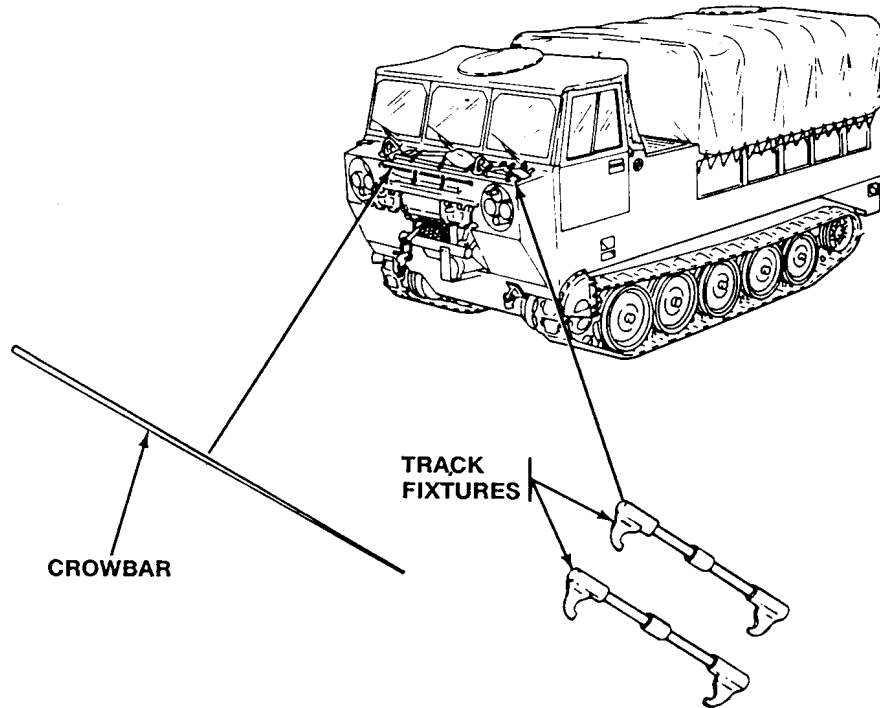

2. Start engine (WP 0013 00 or WP 0014 00).
3. Drive carrier to firm level ground (WP 0020 00 or WP 0021 00).
4. Drive carrier slowly so the track pin to be removed is about halfway between the first road wheel and the drive sprocket or halfway between the idler wheel and fifth road wheel. Do not use steering wheel or press brake pedal to stop carrier.

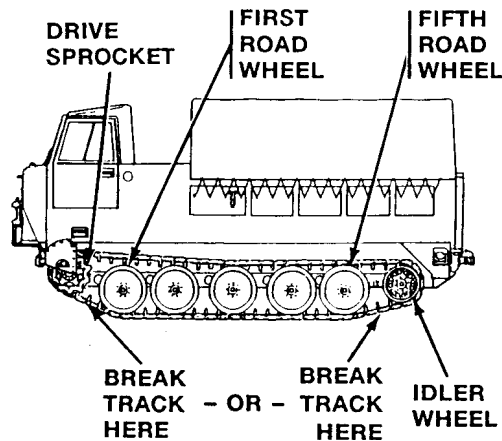

NOTE

Block track with suitable object.

5. Block track on side which is not being broken (WP 0038 00).
6. Stop engine (WP 0023 00 or WP 0024 00).
7. Release track tension all the way on track to be broken (WP 0058 00).

WARNING



You could be injured if track swings out and hits you. Do not stand in front of track being broken.

8. □ Install two track fixtures across the pin to be removed. Tighten track fixtures evenly to about a 20-degree angle between the shoes to be disconnected. There should be about 2 inches (5 cm) between the fixtures and the track at the pin. Use adjustable wrench.

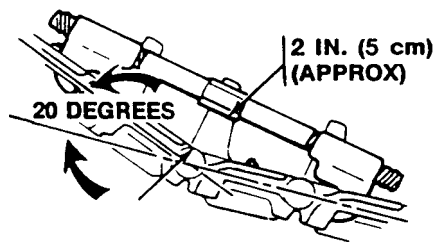
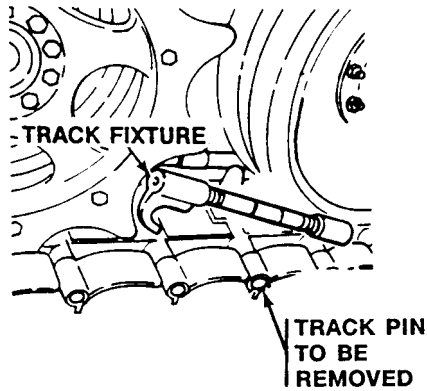

9. Remove track pin nut from track pin to be removed. Use socket wrench handle and 11/16 inch socket wrench.

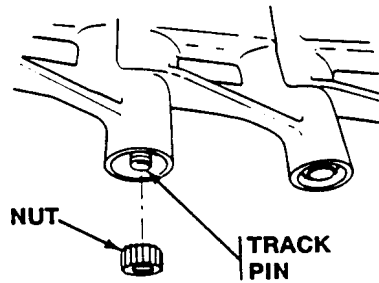

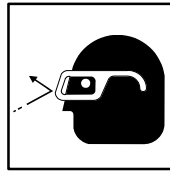
WARNING

Hammering on drive pin punch or track pin may deflect particles of metal or dirt into soldier's eyes. To prevent eye damage, protection (goggles) is necessary.

10. Drive track pin part way out with short end of drive pin punch. Use hammer. Remove drive pin punch.

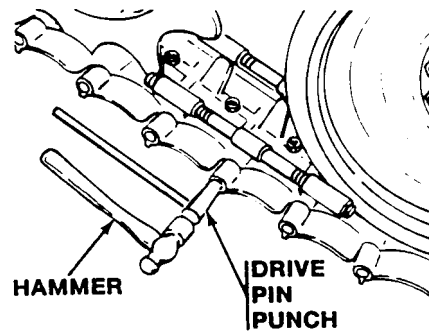

11. Drive track pin all the way out with long end of drive pin punch.

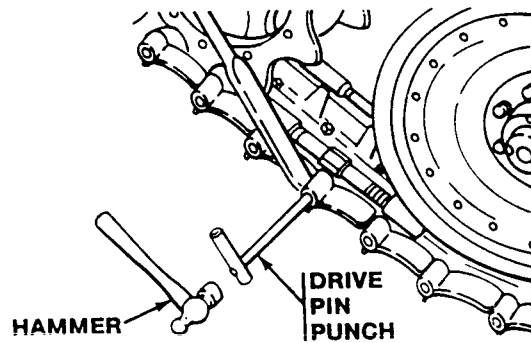

NOTE

Inside track fixture is removed first.

12. If you're planning to add or remove a track shoe, remove two track fixtures. Use adjustable wrench.

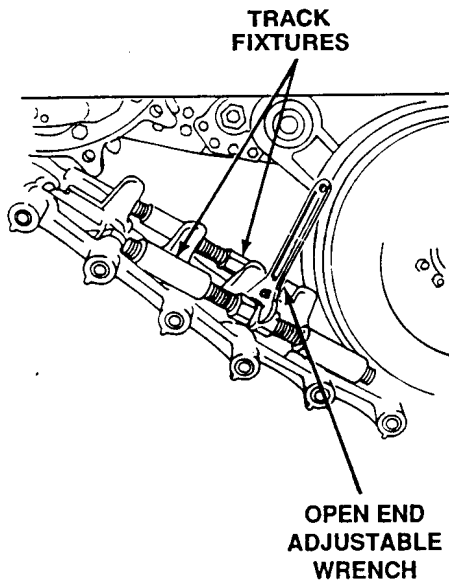

13. Disconnect track. Use crowbar to break track apart.

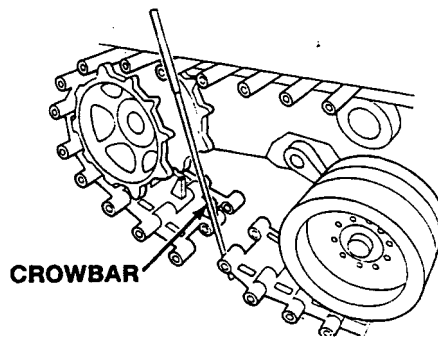

JOIN

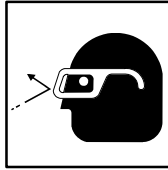
WARNING

Hammering on drive pin punch or track pin may deflect particles of metal or dirt into soldier's eyes. To prevent eye damage, protection (goggles) is necessary.

CAUTION

Track pin threads are easily damaged. Do not force track pin. Tap track pin lightly with hammer.

NOTE

If track is difficult to join, use the track fixtures to pull the track together and open the track adjuster relief valve (T130) (WP 0058 00) or (T150) (WP 0058 01) to relieve any track tension from the track adjuster.

As track pin moves through track hole, the track pin will push the drive pin punch out ahead of it.

1. If track shoe was added or removed, install two track fixtures across place where track is to be connected. Install track fixture on outside of track first. Use adjustable wrench.
2. Move ends of track together with crowbar.

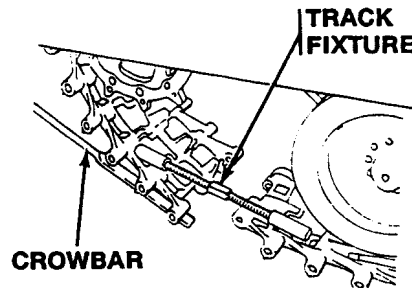
**CAUTION**

Oil or grease will destroy the rubber bushings in track shoes over time. Do not coat track pin with oil or grease.

3. Install a nut flush with one end of the pin.

4. Tighten each track fixture an equal amount to line up track pin holes. Tap long end of drive pin punch through track pin holes to other side of track. Use hammer. Tighten track fixture as needed to obtain 20-degree angle between shoes to be connected. Use adjustable wrench.

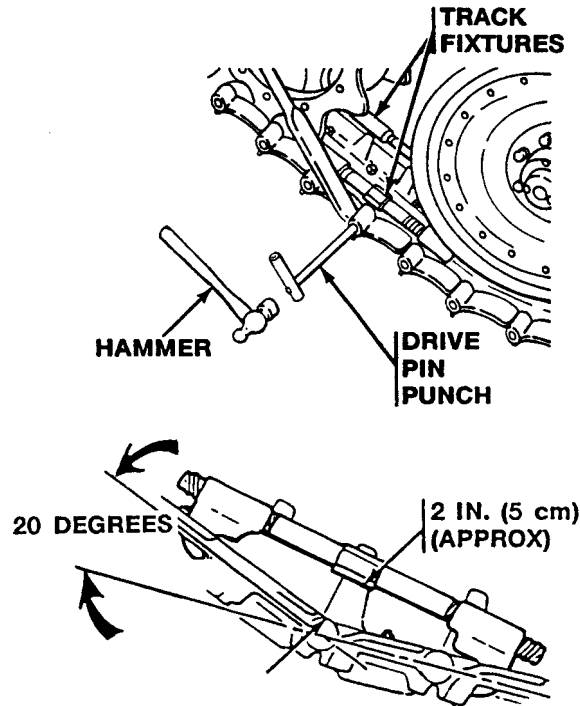

WARNING



Track shoe bushing failure can cause track assembly failure and loss of vehicle control. Soldiers can be killed or injured.

Do not use excessive force that could damage the track shoe bushing while driving in the track pin during assembly.

WARNING

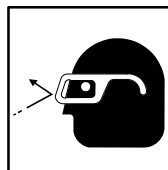

Hammering on drive pin punch or track pin may deflect particles of metal or dirt into soldier's eyes. To prevent eye damage, protection (goggles) is necessary.

5. From inside of track, install track pin in track pin hole. As helper aligns track pin holes with crowbar, lightly tap in track pin. Drive track pin all the way through track. Use hammer.

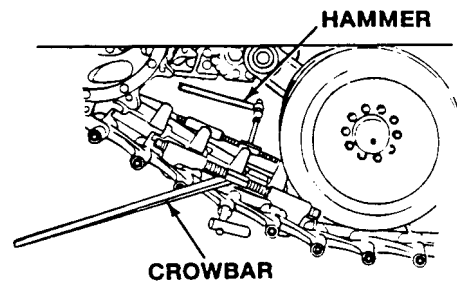

6. Install a nut on the other end of the track pin. Tighten both nuts until 2 or 3 threads show between the nuts and the ends of the pin or about 1/8 inch (0.3 cm). Use socket wrench handle and 11/16 inch socket wrench.

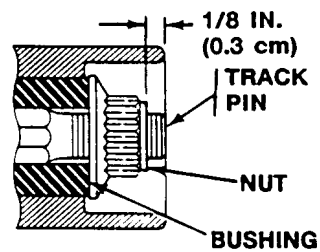

7. Mark nut so unit maintenance can torque it properly. Fill out form DA 2404 or DA 5988-E and notify unit maintenance.
8. Remove two track fixtures. Use adjustable wrench.

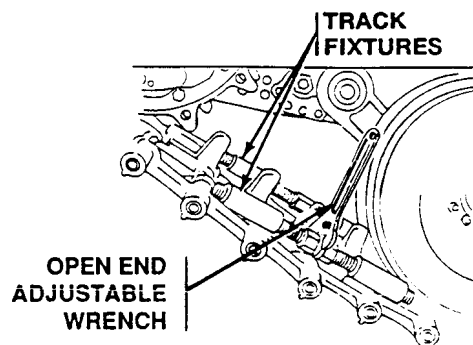

9. Adjust track tension (WP 0058 00).

10. Stow crowbar, track fixtures, and hammer.

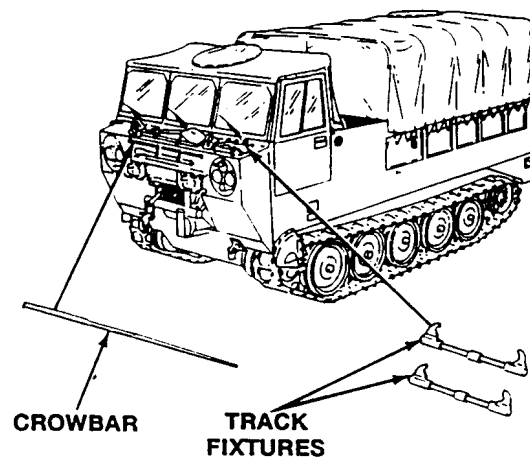

11. Notify unit maintenance of track repair at earliest opportunity. Fill out form DA 2404 or DA 5988-E and notify unit maintenance.

END OF TASK

BREAK/JOIN T150 TRACK

0059 01

THIS WORK PACKAGE COVERS:

- Break Track (page 0059 01-1).
- Join Track (page 0059 01-6)

INITIAL SETUP:

Maintenance Level

Operator

Personnel Required

- Driver
- Crew

Tools and Special Tools

- Crowbar (WP 0081 00, Item 12)
- End Connector Remover (WP 0081 00, Item 32A)
- Grease Gun (WP 0081 00, Item 22)
- Hammer, 2 lb or Hammer, 4 lb. (WP 0081 00, Item 24 or WP 0082 00)
- Handle Extension Wrench (WP 0081 00, Item 16A)
- Handle, Socket Wrench, 3/4 inch drive (WP 0081 00, Item 28)
- Industrial Goggles (WP 0082 00)
- Socket, 1 1/8 inch, 3/4 inch drive (WP 0081 00, Item 38A)
- Tool, Track Pin Alignment (2) (WP 0081 00, Item 39A)
- Track Fixture (2) (WP 0081 00, Item 19)
- Wrench, Open End, Adjustable, 1 5/16 inch (WP 0081 00, Item 43)

Equipment Condition

Engine stopped (WP 0023 00 or WP 0024 00)

BREAK TRACK

1. Unstow crowbar and track fixtures. Remove industrial goggles and hammer from tool bag.

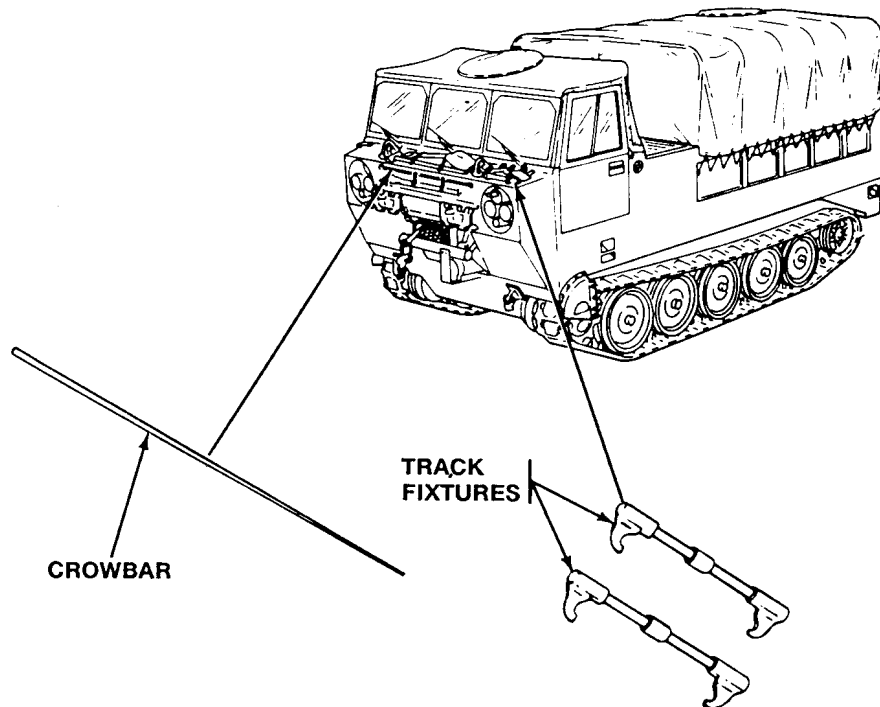

2. Start engine (WP 0013 00 or WP 0014 00).
3. Drive carrier to firm level ground (WP 0020 00 or WP 0021 00).
4. Drive carrier slowly so the track pin to be removed is about halfway between the first road wheel and the drive sprocket or halfway between the idler wheel and fifth road wheel. Do not use steering wheel or press brake pedal to stop carrier.

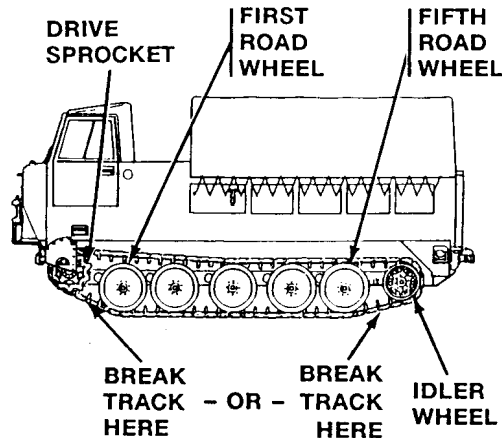

NOTE

Block track with suitable object.

5. Block track on side which is not being broken (WP 0038 00).
6. Stop engine (WP 0023 00 or WP 0024 00).
7. Release track tension all the way on track to be broken (WP 0058 01).

WARNING

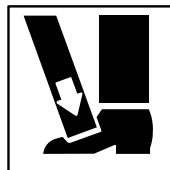

You could be injured if track swings out and hits you. Do not stand in front of track being broken.

8. Using 3/4 inch drive handle wrench, 1-1/8 inch socket, and wrench extension to get more leverage, remove the end connector bolts to the track shoes that need to be removed to break the track.

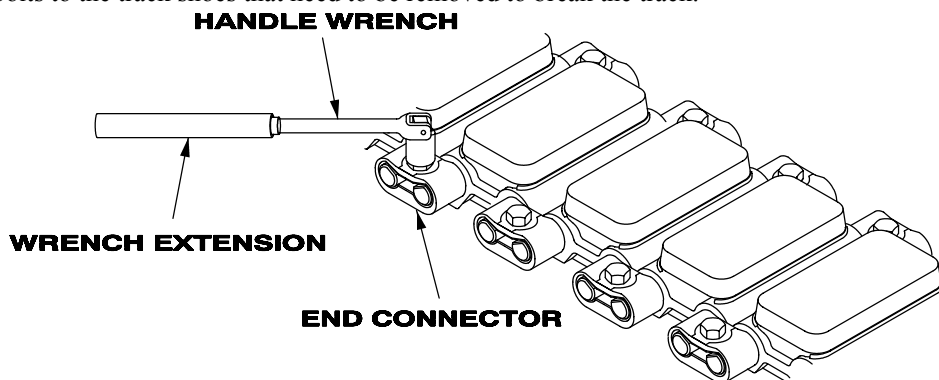

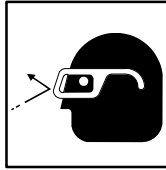
WARNING

Hammering on drive pin punch or track pin may deflect particles of metal or dirt into soldier's eyes. To prevent eye damage, protection (goggles) is necessary.

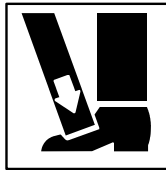
WARNING

You could be injured if track swings out and hits you. Do not stand in front of track being broken.

CAUTION

Keep personnel clear when removing the end connectors to avoid being hit when it is knocked free from the track shoe pins.

NOTE

Remove outside end connector first, then inside end connector.

9. Install two track fixtures on both sides of the track and tighten to pull track shoes together. Use the track end connector tool and hammer to remove the end connector. Repeat using the track end connector tool to remove the opposite end connector.

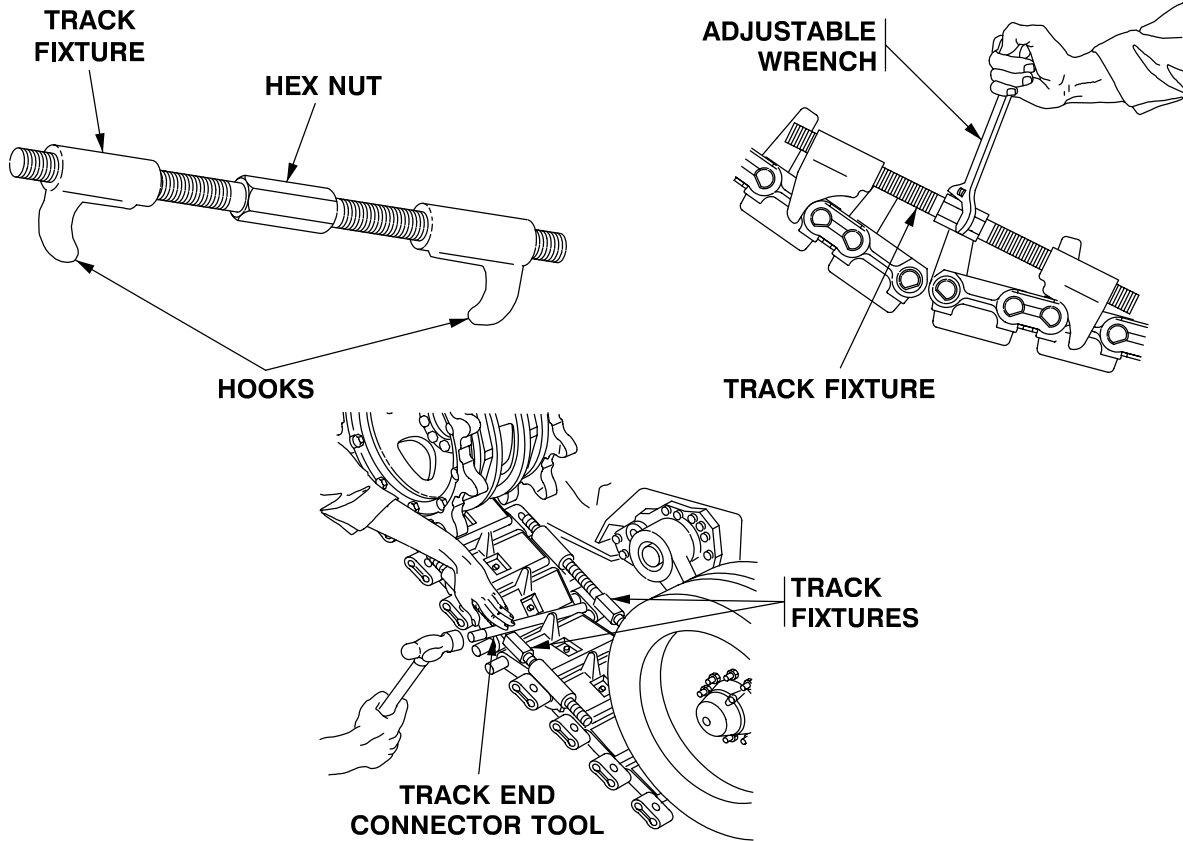

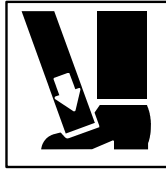
WARNING

You could be injured if track swings out and hits you. Do not stand in front of track being broken.

NOTE

Inside track fixture is removed first.

10. Support track. Use crowbar. Remove inside, then outside track fixtures.

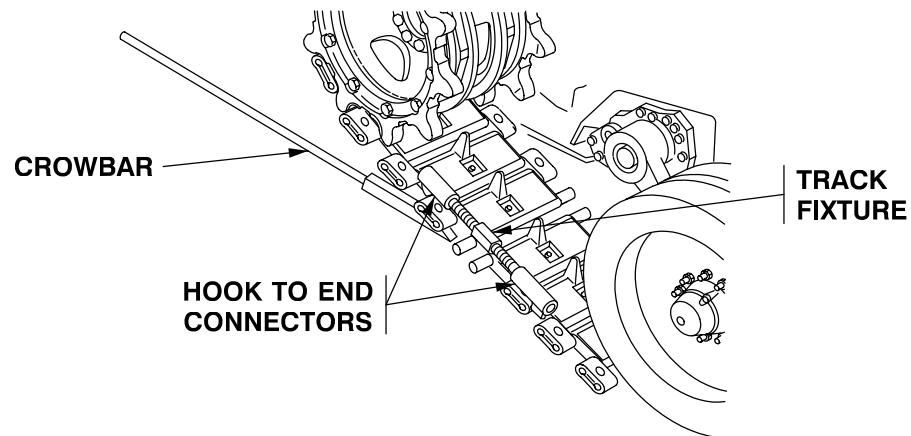

JOIN TRACK

WARNING

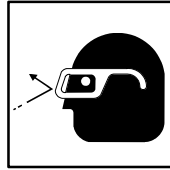

Hammering on drive pin punch or track pin may deflect particles of metal or dirt into soldier's eyes. To prevent eye damage, protection (goggles) is necessary.

NOTE

Center hex nut between hooks on track fixture.

NOTE

Outside track fixtures can be positioned from bottom side to aid in installing track alignment tool.

1. Hold track in position and install two track fixtures across place where track is to be connected. Install outside fixture first.
2. Tighten two track fixtures evenly until ends of track are close enough to install end connectors.

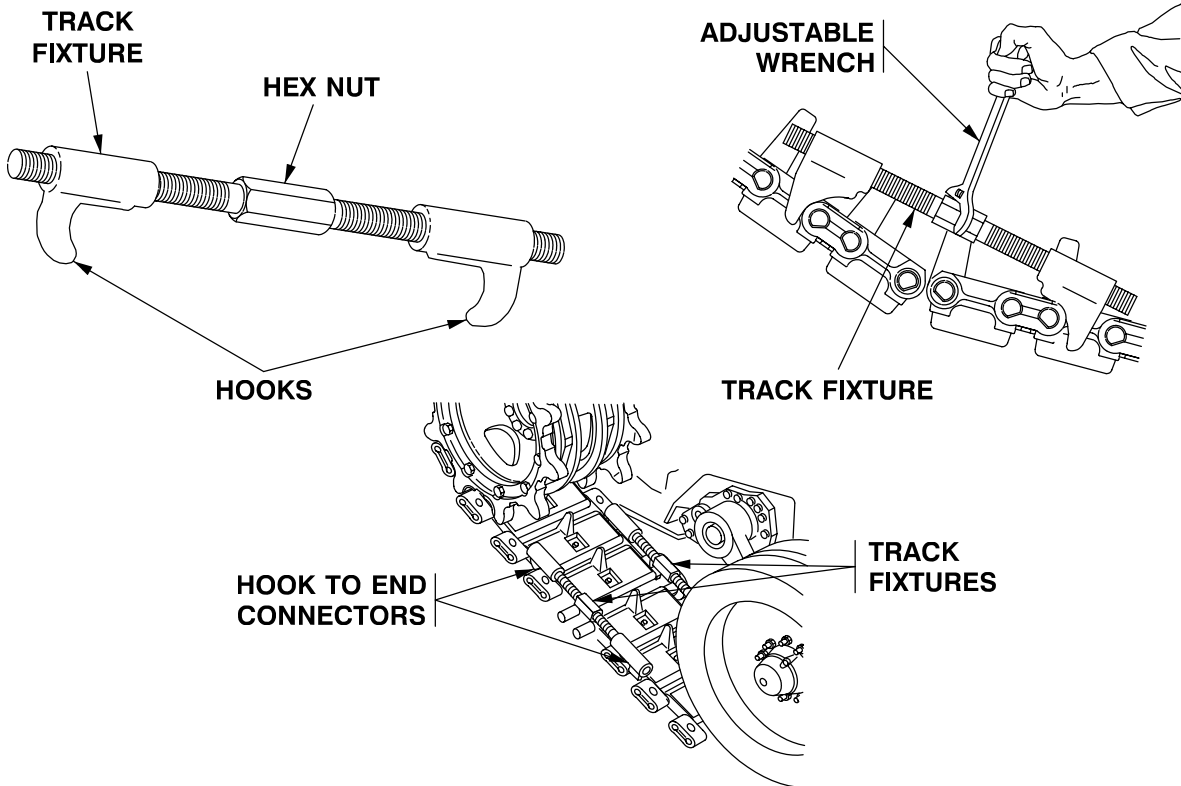

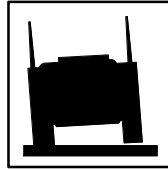
WARNING

Improper number of track shoes may prevent track from being adjusted correctly, creating a safety hazard.

For carriers with new track, ensure there are 66 track shoes on the carrier.

For carriers with old track, ensure there are 65 track shoes on the carrier.

- Place the track alignment tool over one pin on the outside shoe and rest it on the other pin. Tighten both track fixtures evenly to pull the track assembly together until the track alignment tool fits over and seats fully on both track shoe pins. Install the second track alignment tool on the inside track shoe pins, leave on the inside track fixture.

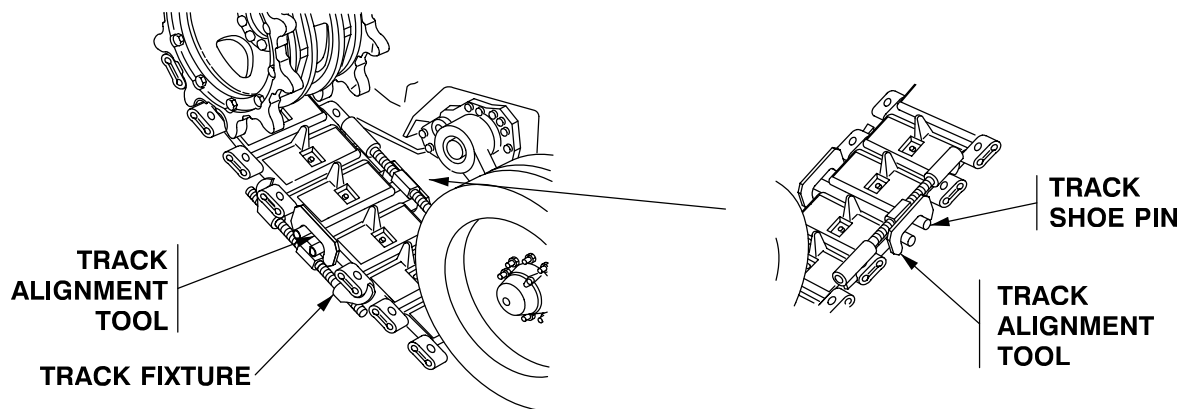

- Remove the outside track fixture. Both track alignment tools will hold the track together. Leave the track fixture on the inside of the track assembly.

WARNING



Do not use the crowbar on the track shoe pins to get leverage. Any scratches may cause the pin to break and cause the track assembly to fall off the vehicle while operating. This may kill soldiers and damage equipment. Use the crowbar as shown in Steps 2 - 5 to get leverage to install end connectors.

NOTE

Place end connector or similar size block on top of the two track shoes being joined. Use the crowbar under the track fixture connected to the inside track shoes end connectors and press down on the block to get the right angle to install the end connector.

5. Make sure the inside track fixture is tight enough to allow the helper to use the crowbar under it with enough pressure to get a slight degree of angle between the two shoes to allow installing the outside end connector.

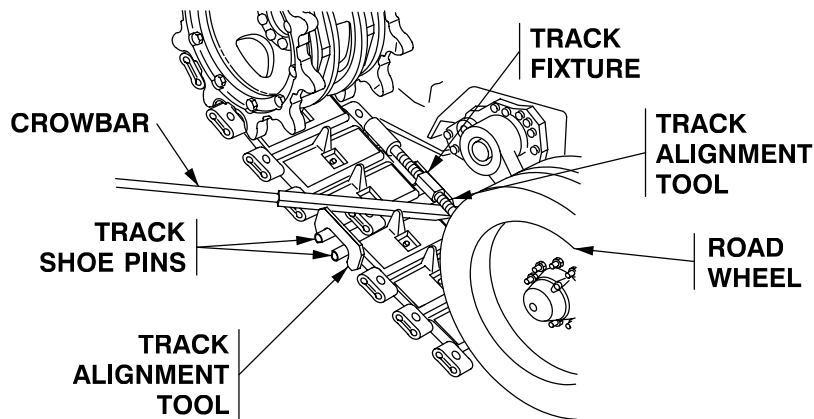

6. Install the end connector on the outside track shoe pins. Get the angle needed to allow the end connector to fit on the track shoe pins. Tap on the end connector close to the alignment tool. Remove the track alignment tool. Tap the end connector fully onto track shoe pins. Make sure it touches both track shoe bodies.

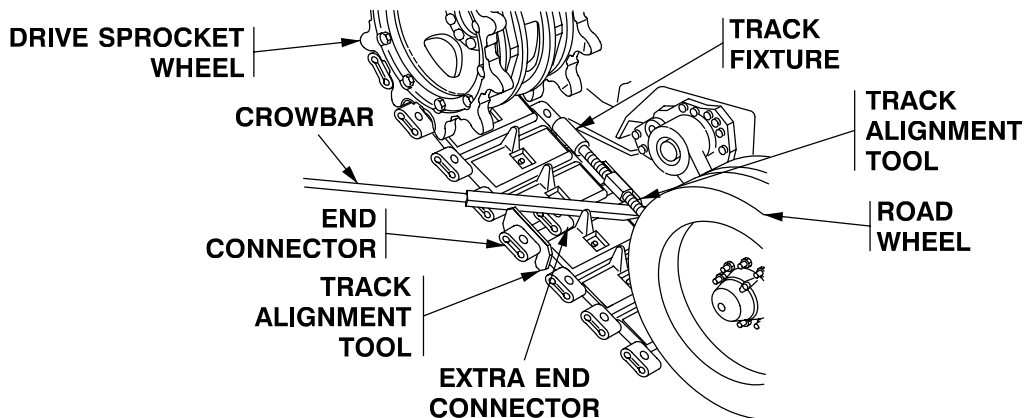

7. Install inside end connector. Only a slight amount or no leverage is needed to install the second connector if the outside end connector is already installed.

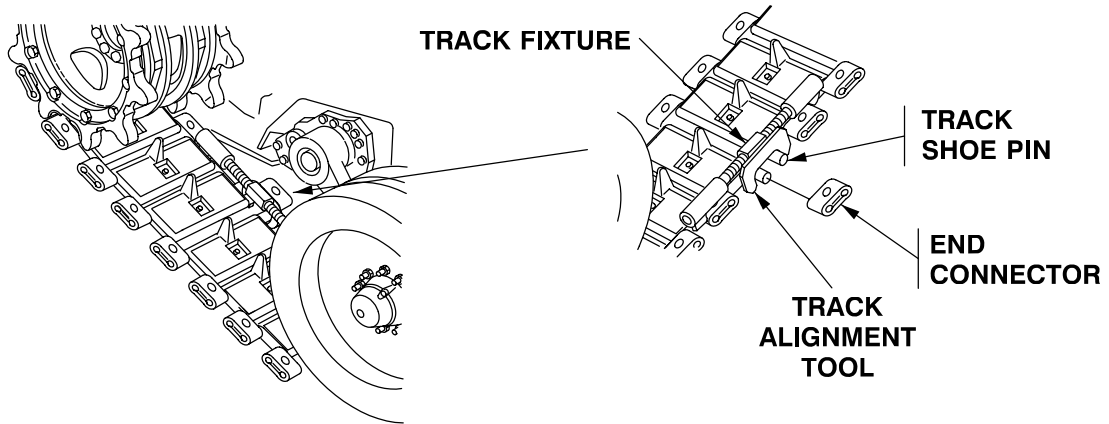

8. □ Once the end connector is installed halfway on the inside of the track assembly, remove the track fixture and track alignment tool. Finish installing the end connector all the way on the track shoe pins until it touches the track shoe body.

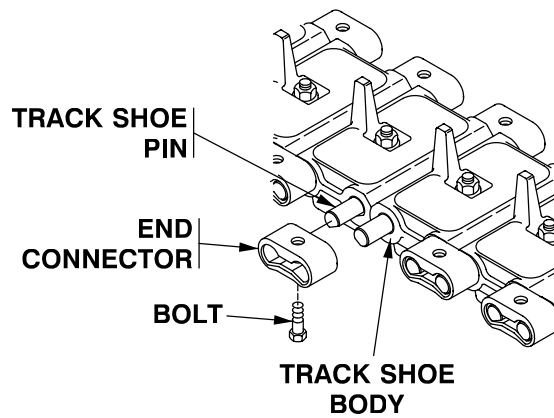

WARNING



Not getting the bolt tight enough may result in death to personnel and damage to equipment if the end connectors fall off during movement of the vehicle. Use the wrench extension over the breaker bar to achieve more leverage when tightening the end connector bolt.

NOTE

Move vehicle far enough to position end connectors that need to be tightened on top.

NOTE

Mark the location of the end connectors so unit maintenance can torque them properly. Take the vehicle to unit maintenance as soon as possible to have the end connector bolts torqued to the proper value.

9. Secure both end connector bolts using the 3/4 inch drive handle wrench and handle extension to get enough torque until you can get it to unit maintenance to torque it properly. Mark the end connectors you have loosened and retightened so unit maintenance can tighten to the right torque value. Fill out form DA 2404 or DA 5988-E and notify unit maintenance.

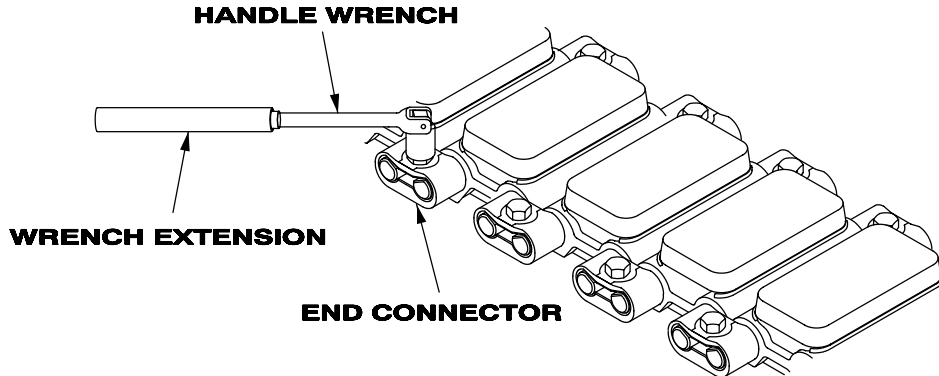

10. Adjust track tension (WP 0058 01).

END OF TASK

REMOVE/INSTALL T130 TRACK SHOE

0060 00

THIS WORK PACKAGE COVERS:

Removal (page 0060 00-1).
 Installation (page 0060 00-3).

INITIAL SETUP:

Maintenance Level

Operator

Personnel Required

Driver
 Helper

Tools and Special Tools

Crowbar (WP 0081 00, Item 12)
 Drive Pin Punch (WP 0081 00, Item 32)
 Hammer, 2 lb (WP 0081 00, Item 24)
 Industrial Goggles (WP 0082 00)
 Socket Wrench Handle (WP 0081 00, Item 27)
 Socket Wrench, 11/16 inch (WP 0081 00, Item 38)
 Socket Wrench, 3/4 inch (WP 0081 00, Item 38)
 Track Fixture (WP 0081 00, Item 19)

Equipment Condition

Carrier on level surface
 Engine stopped (WP 0023 00 or WP 0024 00)

REMOVAL

1. Break track at track shoe to be removed (WP 0059 00).
2. Remove nut from track pin of shoe to be removed. Use socket wrench handle and 11/16 inch socket wrench.

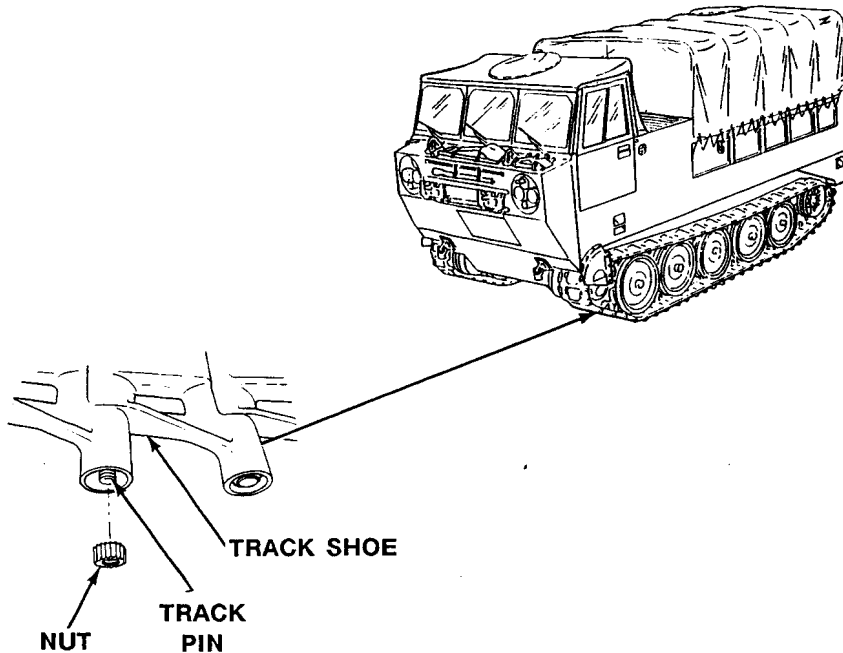

WARNING

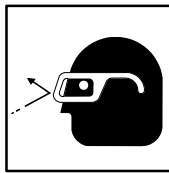

Hammering on drive pin punch or track pin may deflect particles of metal or dirt into soldier's eyes. To prevent eye damage, protection (goggles) is necessary.

3. Drive track pin part way out with short end of drive pin punch. Use hammer. Remove drive pin punch.
4. Drive track pin all the way out with long end of drive pin punch. Use hammer. Keep short end up. Remove drive pin punch.

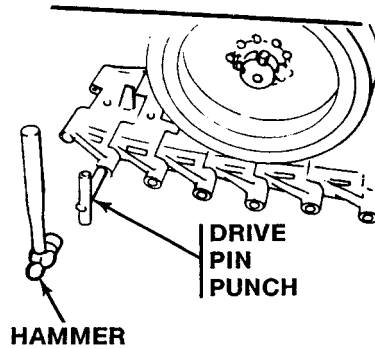

5. Remove track shoe from track. Use crowbar.

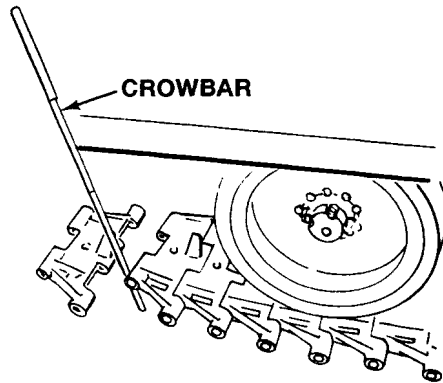

6. If removed shoe is not serviceable, return to unit maintenance. If removed shoe is serviceable, install the track pin and nuts in the shoe. Stow shoe on left front of carrier just above the track. Use socket wrench handle and 3/4 inch socket wrench.

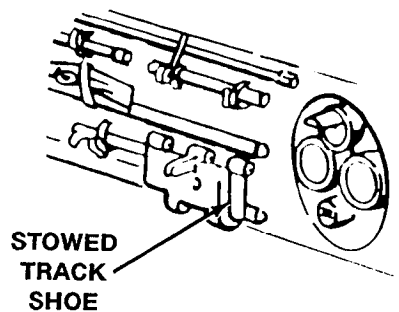

7. Join track (WP 0059 00).
8. Install nut on track pin. Use socket wrench handle and 11/16 inch socket wrench.

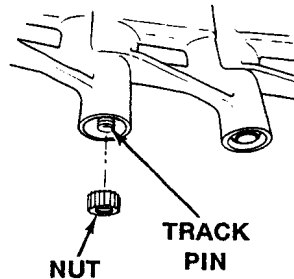

9. Adjust track for correct tension (WP 0058 00).
10. Mark nut so unit maintenance can torque it. Notify unit maintenance to torque marked track pin nuts at earliest opportunity.

INSTALLATION

1. Unstow a spare track shoe from left front of carrier. Use socket wrench handle and 3/4 inch socket wrench.

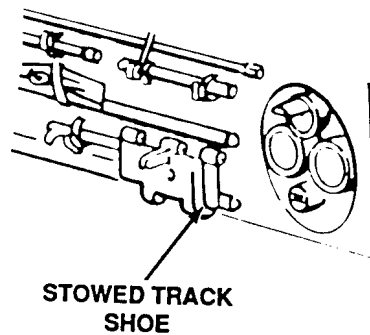

2. Break track to install track shoe (WP 0059 00).
3. Remove nut from track pin of replacement track shoe. Use socket wrench handle and 11/16 inch socket wrench.

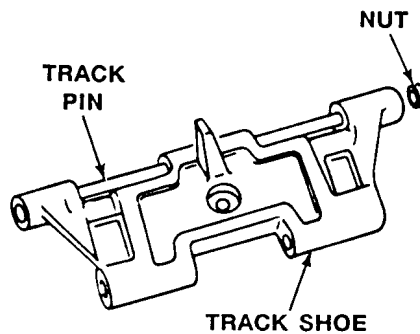

WARNING

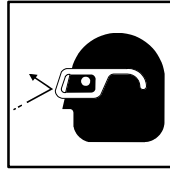

Hammering on drive pin punch or track pin may deflect particles of metal or dirt in soldier's eyes. To prevent eye damage, protection (goggles) is necessary.

4. Drive track pin part way out with short end of drive pin punch. Use hammer. Remove drive pin punch.

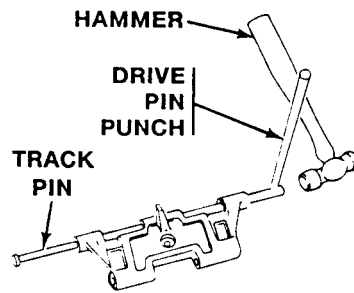

5. Drive track pin all the way out with long end of drive pin punch. Use hammer. Remove drive pin punch.

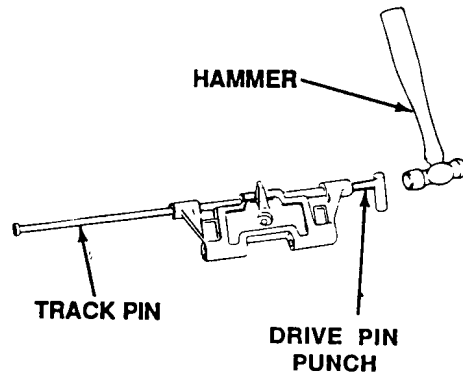

CAUTION

Do not use any oil or grease on track pin. Oil or grease will destroy the rubber bushings in the track shoes over time. The track pins have a protective coating that does not need to be removed.

6. Install nut flush on track pin. Use socket wrench handle and 11/16 inch socket wrench.
7. Install replacement track shoe in lower part of track. Align track pin holes.

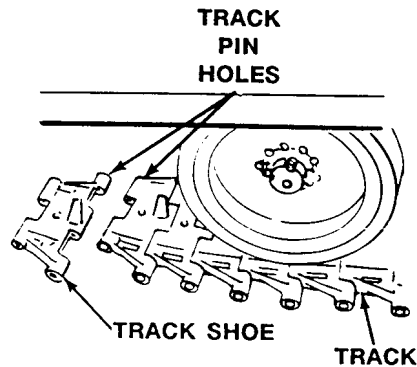
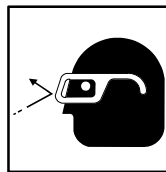
**WARNING**

Hammering on drive pin punch or track pin may deflect particles of metal or dirt in soldier's eyes. To prevent eye damage, protection (goggles) is necessary.

8. Obtain 20-degree angle between track shoes to be connected.

WARNING

Track shoe bushing failure can cause track assembly failure and loss of vehicle control. Soldiers can be killed or injured.

Do not use excessive force that could damage the track shoe bushing while driving in the track pin during assembly.

9. Install track pin in track shoe.

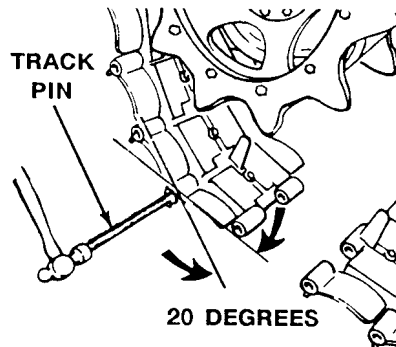

10. Join track (WP 0059 00).

11. Install nut on track pin. Use socket wrench handle and 11/16 inch socket wrench.

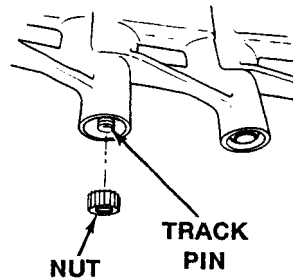

12. Adjust track for correct tension (WP 0058 00).

13. Mark nut so unit maintenance can torque it. Notify unit maintenance to torque marked track pin nuts at earliest opportunity. Fill out form DA 2404 or DA 5988-E and notify unit maintenance.

END OF TASK

REMOVE/INSTALL T150 TRACK SHOE

0060 01

THIS WORK PACKAGE COVERS:

Removal (page 0060 01-1).
 Installation (page 0060 01-2).

INITIAL SETUP:

Maintenance Level

Operator

Personnel Required

Driver
 Crew

Tools and Special Tools

End Connector Remover (WP 0081 00, Item 32A)
 Extension, Wrench Handle (WP 0081 00, Item 16A)
 Hammer, Sledge Hand, 6 lb. or Hammer, 4 lb.
 (WP 0081 00, Item 25 or WP 0082 00)
 Handle, Socket Wrench, 3/4 inch drive
 (WP 0081 00, Item 28)
 Socket, 3/4 inch drive, 1 1/8 inch opening, 6 pt
 (WP 0081 00, Item 38A)
 Tool, Track Pin Alignment (2) (WP 0081 00, Item 39A)

Equipment Condition

Carrier on level surface
 Engine stopped (WP 0023 00 or WP 0024 00)

REMOVAL

1. Remove spare track from stowage.
2. Break track (WP 0059 01).
3. Remove track shoe from track.
 - a. Remove two bolts from inside and outside end connectors.
 - b. Remove two end connectors from track shoes.

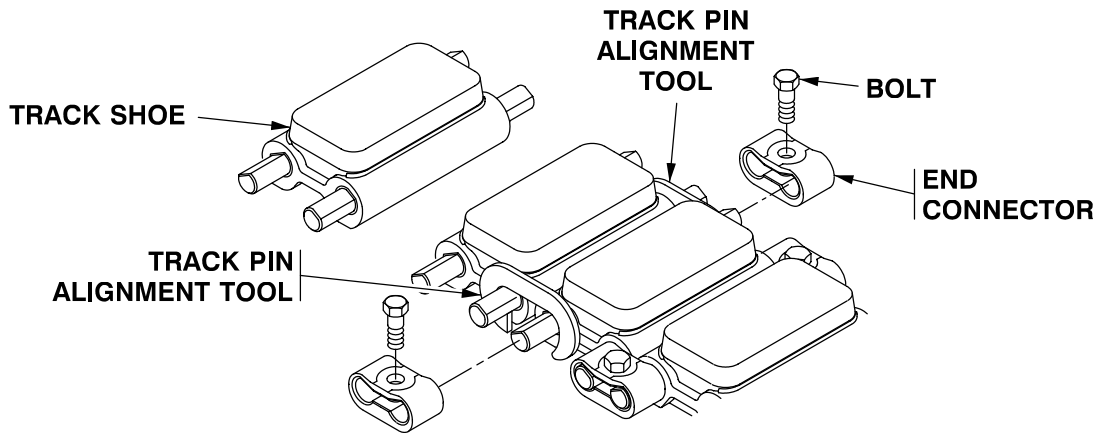

INSTALLATION

WARNING

Loss of track end connector can cause track throw and loss of vehicle control. Soldiers can be killed or injured. Mark end connector bolts. Notify maintenance to torque bolts.

NOTE

Position track shoes at slight angle to install end connectors on both shoe pins. Proper tightening of end connector bolts keeps them from coming loose. Have unit maintenance properly torque as soon as possible.

1. Install new track shoe on track.

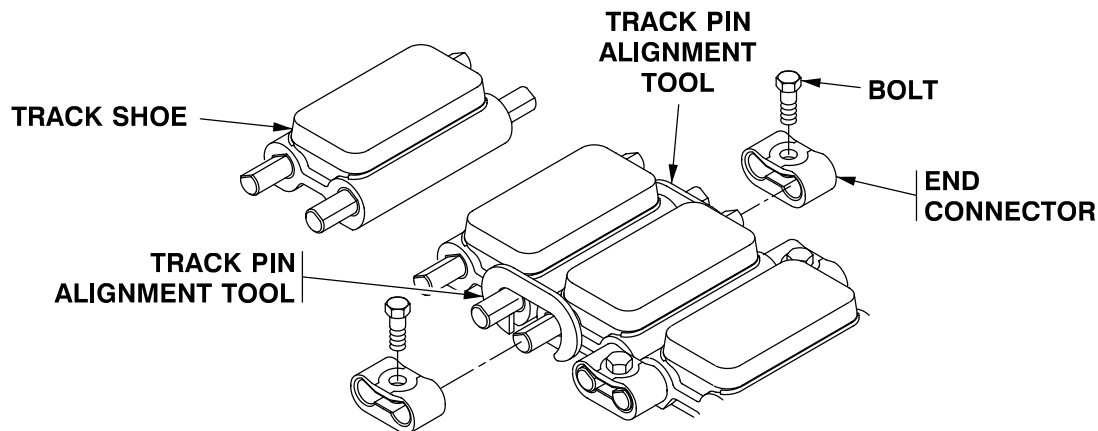

- a. Install two track pin alignment tools over track shoe pins. Install two track end connectors on track shoes. Remove track pin alignment tools before driving end connectors flush with pin ends.
 - b. Drive end connectors flush with pin ends and install bolts on each end connector.
 - c. Tighten bolts using extension wrench on handle with socket.
2. Mark track that was replaced so bolts can be torqued later.
 3. Join track (WP 0059 01).
 4. Stow spare track shoe.
 5. Notify unit maintenance to torque bolts. Fill out form DA 2404 or DA 5988-E and notify unit maintenance.

END OF TASK

ASSEMBLE T130 TRACK SHOE SECTIONS OFF VEHICLE

0060 02

THIS WORK PACKAGE COVERS:

Assembly (page 0060 02-1).

INITIAL SETUP:

Maintenance Level

Operator

Personnel Required

Driver

Helper (H)

Tools and Special Tools

Crowbar (WP 0081 00, Item 12)

Drive Pin Punch (WP 0081 00, Item 32)

Grease Gun (WP 0081 00, Item 22)

Hammer, 2 lb (WP 0081 00, Item 24)

Industrial Goggles (WP 0082 00)

Open End Wrench, Adjustable (WP 0081 00, Item 43)

Socket Wrench, 11/16 inch (WP 0081 00, Item 38)

Track Fixtures (WP 0081 00, Item 19)

Wrench Handle (WP 0081 00, Item 27)

Equipment Condition

Track on level surface

ASSEMBLY

NOTE

Track shoe sections may come in 7 or 8 shoes per section. Make sure to count the number of shoes during assembly. For all M548 FOV there are 66 track shoes required for the left side and right side. Inspect each track shoe to see if anything is wrong before it is assembled.

1. Match two sections of track. Have helper assist.

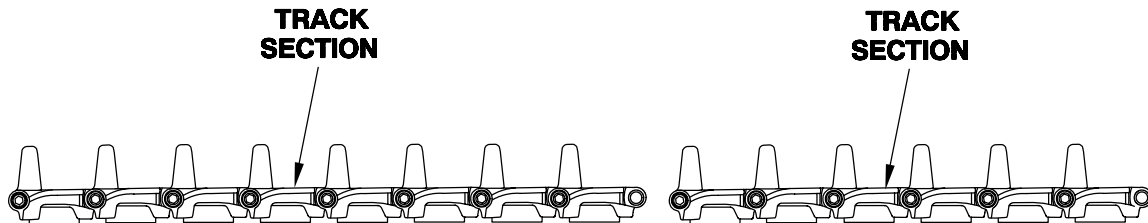

2. Remove nut from track pin. Use 1/2 inch drive socket handle and 11/16 inch socket.

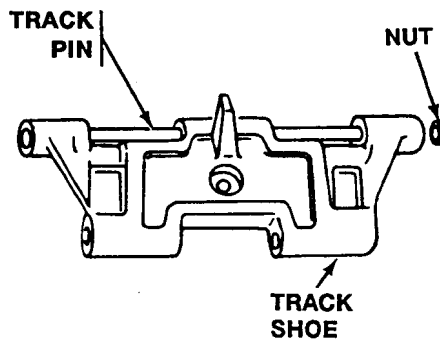

WARNING

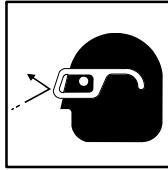

Always wear eye protection when using a hammer. Eye injury may result if metal chips contact eyes.

CAUTION

Track pin threads are easily damaged. Do not force track pin. Tap track pin lightly with hammer.

3. Drive track pin part way out with short end of drive pin punch. Use hammer. Remove drive pin punch.

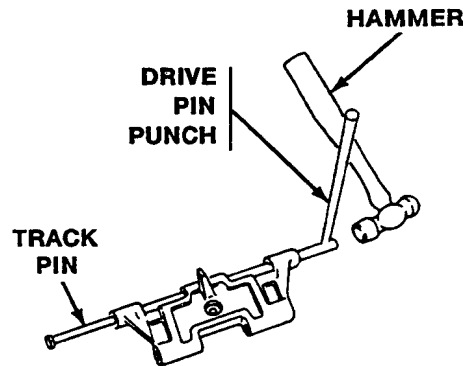

4. Drive track pin all the way out. Use hammer and long end of drive pin punch.

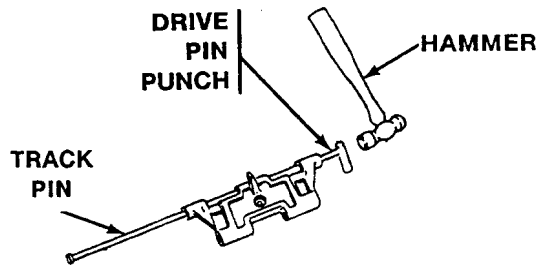

5. Insert drive pin punch into track shoes to keep sections together.

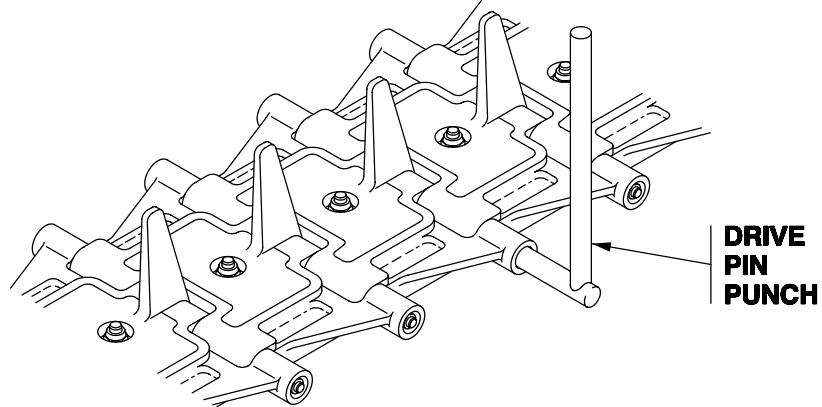

6. Insert crowbar in first track shoe slot. Lift or tilt track to obtain the 20 degrees or approximately 5-inch lift as shown below to get the right angle for installing the track pin through both track shoes. Adjust crow bar angle to help allow the track pin to be driven smoothly into place.

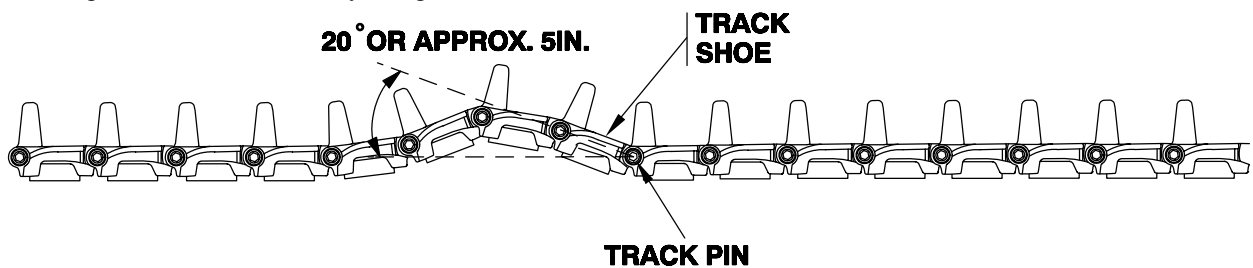

WARNING

Track shoe bushing failure can cause track assembly failure and loss of vehicle control. Soldiers can be killed or injured.

Do not use excessive force that could damage the track shoe bushing while driving in the track pin during assembly.

WARNING

Track shoe bushing failure due to improper angle of track during pin assembly can cause track assembly failure and loss of vehicle control. Soldiers can be killed or injured.

Make sure track is assembled with the right amount of angle or lift as shown below. Properly assembled track will lay flat. Incorrectly assembled track will bulge upward.

CAUTION

Oil or grease will damage the track shoe bushing over time. Do not use oil or grease on track pin during assembly. Track pins have a coating to protect them from rusting that does not need to be removed.

7. Insert track pin into track shoe. Use 2 lb hammer. Adjust crowbar angle to obtain 20 degrees or approximately 5-inch angle as shown.
8. Install and tighten nut until one full thread shows on track nut. Use 1/2 inch drive socket wrench handle and 11/16 inch socket.
9. Scribe a mark with a screwdriver above the nut on the metal surface of shoe, for torquing by unit maintenance. Contact unit maintenance.

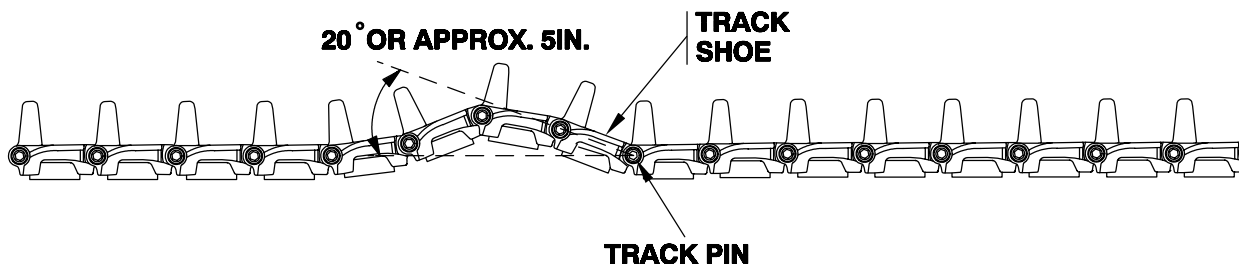

10. Repeat Steps 1 - 9 until you have 66 track shoes in one assembly.

END OF TASK

REMOVE/INSTALL T130 TRACK PAD

0061 00

THIS WORK PACKAGE COVERS:

- Removal (page 0061 00-1).
- Installation (page 0061 00-1).
- Replace Bumper Mounted Track Pad (page 0061 00-2).

INITIAL SETUP:

Maintenance Level

Operator

Personnel Required

Driver

Tools and Special Tools

- Hammer, 2 lb (WP 0081 00, Item 24)
- Socket Wrench Handle (WP 0081 00, Item 27)
- Socket Wrench, 15/16 inch (WP 0081 00, Item 38)

Equipment Condition

- Carrier on level surface
- Engine stopped (WP 0023 00 or WP 0024 00)

REMOVAL

NOTE

The track pad is attached by a built-in stud and one nut.

1. Remove the track pad from the track shoe. Loosen nut and pry pad out of the hole in the shoe. Use socket wrench handle and 15/16 inch socket wrench.

CAUTION

Use care not to damage threads on stud if you expect to use pad again.

2. Loosen stuck track pad by tapping on end of stud. Use hammer.

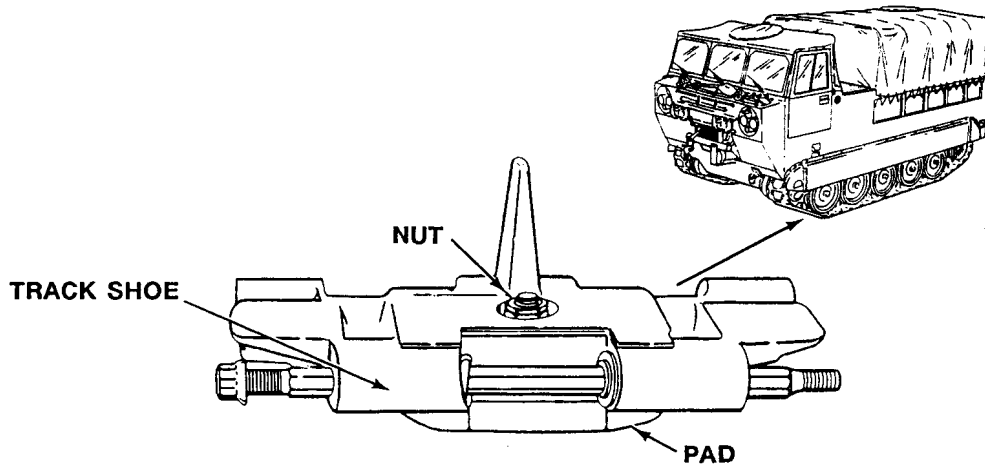

INSTALLATION

1. Install track pad on track shoe. Install nut on stud.
2. Tighten nut using socket wrench handle and 15/16 inch socket wrench.

3. Mark pad and fill out form DA 2404 or DA 5988-E and notify unit maintenance so they can torque nut properly.

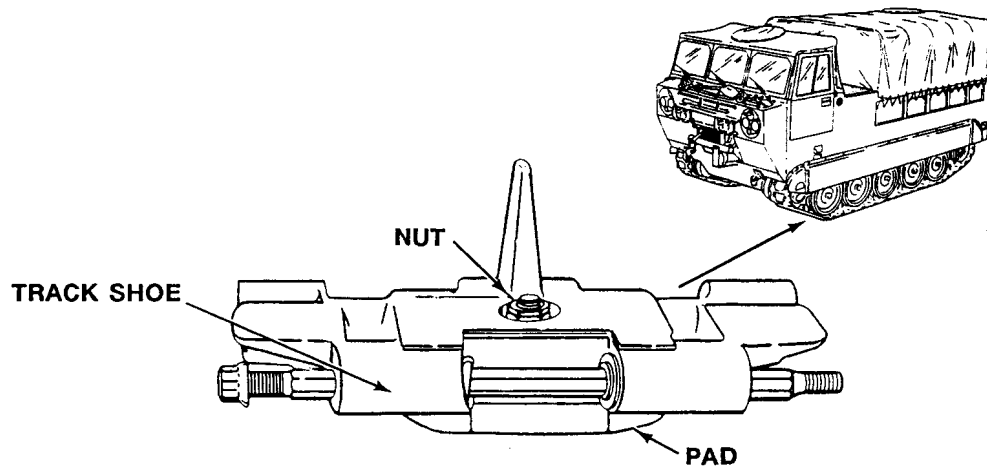

REPLACE BUMPER MOUNTED TRACK PAD

NOTE

Install worn track pads on the rear bumper to have spare track pads available and to help protect the carrier and anything you might back into.

1. Remove track pad from bumper by unscrewing nut and taking track pad off. Use socket wrench handle and 15/16 inch socket wrench.
2. Install track pad on rear bumper and tighten nut to secure track pad in place. Use socket wrench handle and 15/16 inch socket wrench.

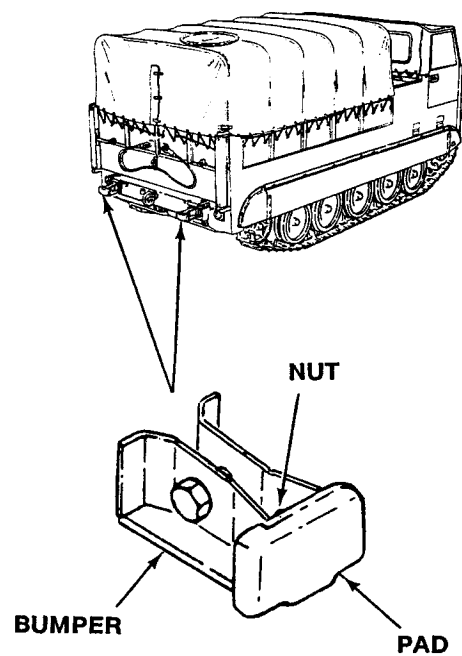

END OF TASK

TRACK SHOE WEAR LIMITS

0061 01

THIS WORK PACKAGE COVERS:

Track Shoe Wear Limits (page 0061 01-1).

INITIAL SETUP:

Maintenance Level

Operator

Personnel Required

Soldier

Tools and Special Tools

Profile Gauge (T130) (WP 0081 00, Item 21)
 Track Tension and Sprocket Wear Gauge (T150)
 (WP 0081 00, Item 21A)

Equipment Condition

Carrier parked on level ground
 Engine stopped (WP 0023 00 or WP 0024 00)

TRACK SHOE WEAR LIMITS

1. **Grouser height (T130 only).** Measure the height of the top edge of the grouser above the bushing housing. If the shoe has less than 1/8-inch of grouser height left, it must be replaced.

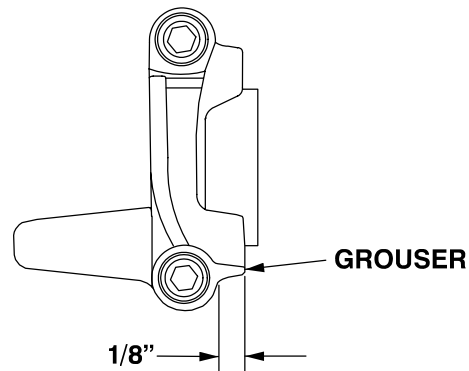
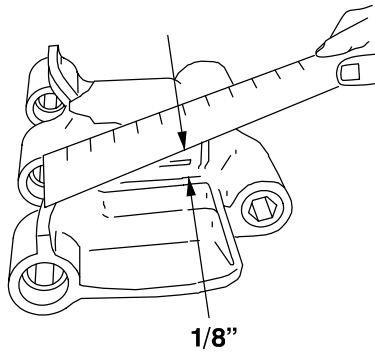

2. **Track shoe pad (both T130 and T150).** Measure the height of the top of the track shoe pad above the top of the grouser. If this is less than 1/16-inch, the pad is too worn. Have unit maintenance replace the pad.

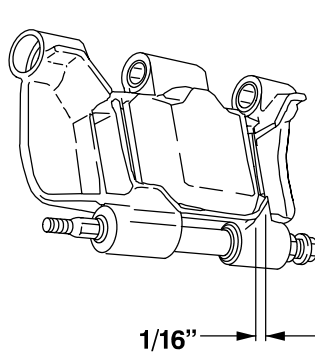

T130

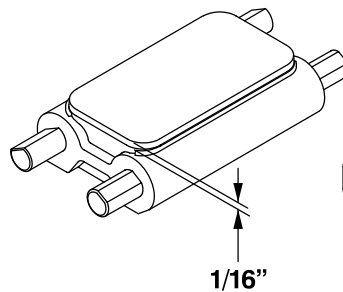
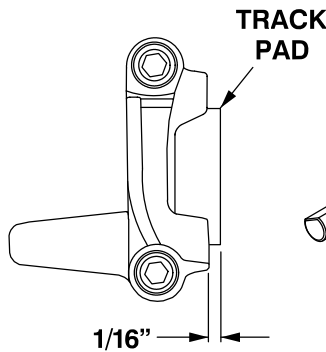

T150

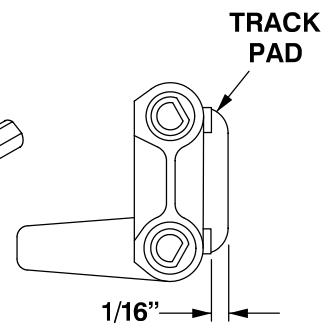

3. **Drive sprocket flange (leading) (T130 only).** On the two bushing end of the shoe, measure the distance from the edge of the sprocket drive hole to the outside of the bushing housing. If the distance is less than 1-15/16-inch, the shoe must be replaced.

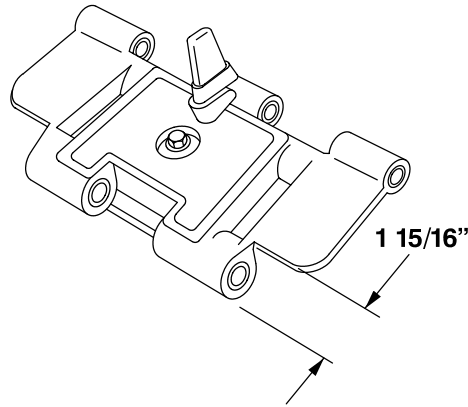

4. **Drive sprocket flange (trailing) (T130 only).** At the three bushing ends of the shoe, measure from the edge of the sprocket drive hole to the nearest outside edge of the shoe. If it's less than 1/2-inch, the shoe must be replaced.

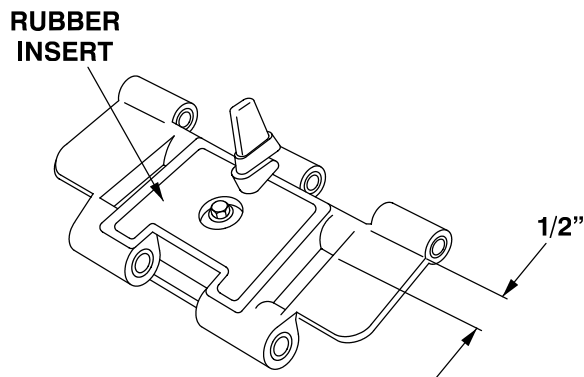

5. **Track shoe forging (T130 only).** Look for cracks in the grousers, pad recess, the ears (track web area outside the grousers and sprocket drive holes), and the sides of the sprocket drive holes. If the cracks are less than 1-inch long in these plates, get the cracks welded. If cracks are one inch or longer, or in any other place, the shoe must be replaced.

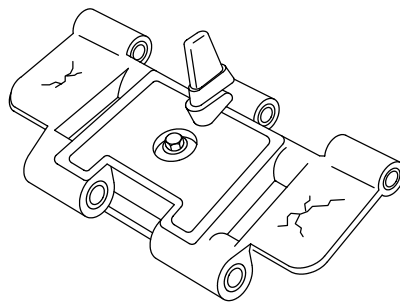

6. **Center guide (T130 and T150).** The center guide has to be 1/8-inch thick or more, measured 2 3/4-inch from the face of the track. The center guide must be at least 2 3/4-inches long. Report to unit maintenance to replace the track shoe. Use track gauge (WP 0081 00, Item 21A) as shown for T150. If gauge touches track shoe, it is bad. Replace shoe.

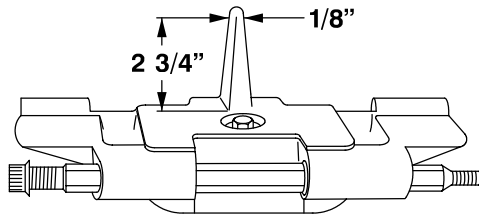

T130

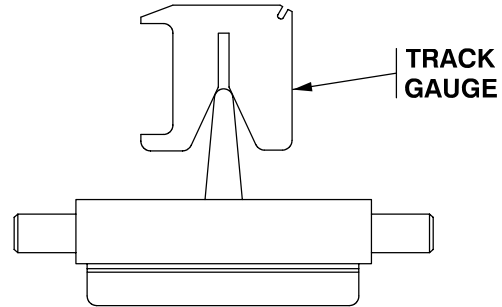

T150

7. **Rubber inserts (T130 only).** Look at the rubber inserts that bear on the road wheels. If there is 3/8-inch or more separation between the rubber and metal all the way around, the shoe must be replaced. If the insert shows chunking 1/2-inch or more deep on 10 percent or more of its surface, the shoe must be replaced.

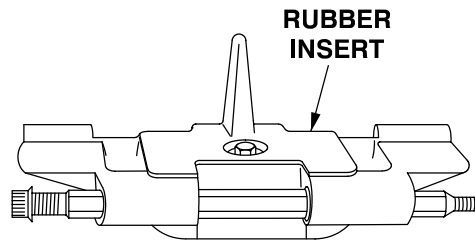

T130

8. **Bushing wear (T130 and T150).** With the track on the carrier and under normal tension, insert pins of track and sprocket gauge into track shoes. (T130) If pins of track gauge (WP 0081 00, Item 21) enter both track shoes freely, track bushings are OK; if pins do not enter both track shoes freely, bushings are worn. Report any worn bushings to unit maintenance. (T150) If track gauge (WP 0081 00, Item 21A) enters both end connector pins, bushings are worn. Notify unit maintenance to replace track shoe.

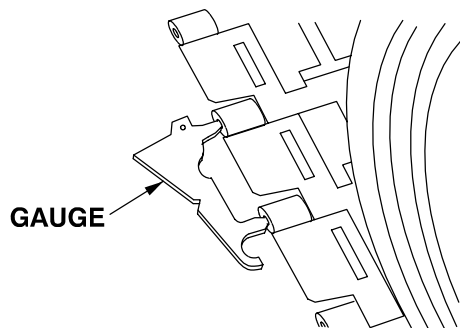

T130

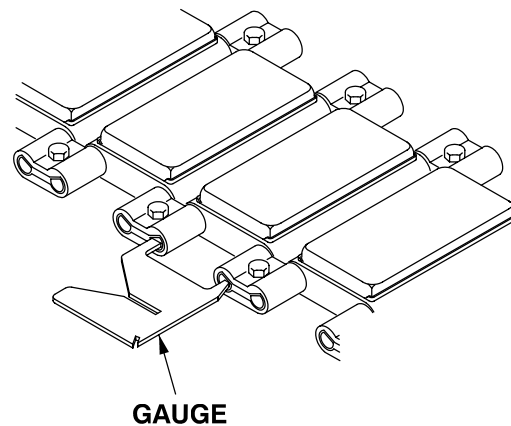

T150

9. **Dead shoes (T130 and T150).** Look for shoes with one end that sticks up above the same side of the next shoes on upper side of track. This is caused by the rubber bushing rotating in the shoe. Record fault on DA Form 2404 and report to unit maintenance. If carrier has extra shoes stowed on front of carrier, replace dead shoes (T130) (WP 0060 00) or (T150) (WP 0060 01).

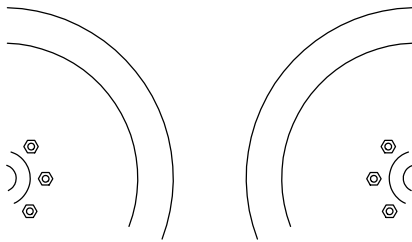
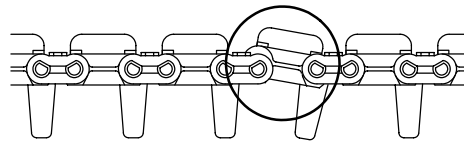
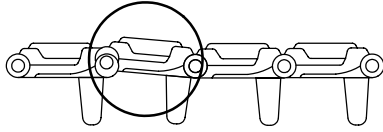

T130

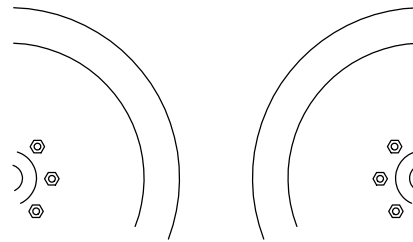

T150

10. **End Connectors (T150 only).** Visually look at the outside edge thickness of the end connectors. If any end connector appears to be worn where the sprocket teeth make contact more than the rest of the end connectors, the end connector must be removed to measure it with the track gauge (WP 0081 00, Item 21A). The inside portion is generally where it will wear out and can only be checked when it is removed from the track shoe. If you remove the end connector to measure it and reinstall it, make sure you have unit maintenance torque it properly before operating the carrier for any length of time or going on any missions. Measure the outside edge thickness of end connector. If the track gauge fits over the end connector edge, end connector is worn. Have unit maintenance replace end connector.

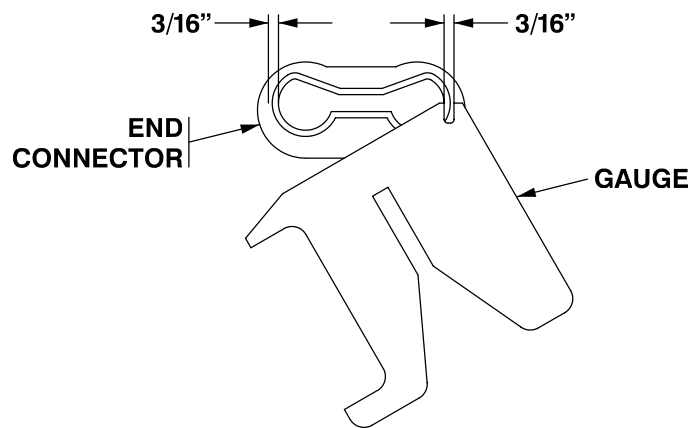

END OF TASK

INSPECT T130 SPROCKET WEAR

0062 00

THIS WORK PACKAGE COVERS:

Inspection (page 0062 00-1).

INITIAL SETUP:

Maintenance Level

Operator

Equipment Condition

Engine stopped (WP 0023 00 or WP 0024 00)

Carrier blocked (WP 0038 00)

Tools and Special Tools

Profile Gauge (WP 0081 00, Item 21)

Personnel Required

Driver

INSPECTION

NOTE

New style drive sprocket will have an indented circle on one sprocket tooth, on each side of the sprocket. This is a visible wear indicator on when to reverse the drive carrier or replace the sprockets if both sides are worn to the wear indicator. The wear indicator may not be on the same tooth for both sides.

NOTE

If carrier throws a track or track makes excessive noise, it could be caused by a worn track drive sprocket.

1. Position profile gauge on two screws of drive sprocket wheel of noisy or thrown track.
2. Edge contour of teeth must extend beyond edge of gauge. The profile gauge is not required if the drive sprockets have a wear indicator on one tooth. If the sprocket tooth is worn to the wear indicator at any point, sprocket must be reversed or replaced. Notify unit maintenance.

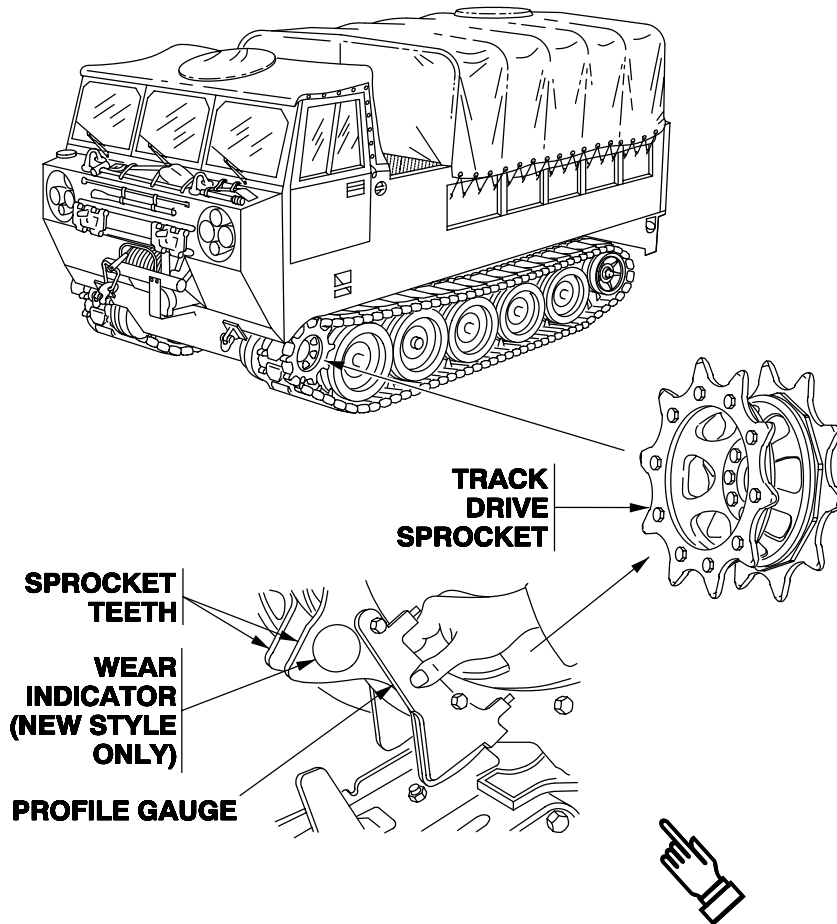

END OF TASK

MAINTENANCE OF AIR CLEANER ELEMENT (M548A1)

0063 00

THIS WORK PACKAGE COVERS:

- Removal (page 0063 00-1).
- Cleaning (page 0063 00-2).
- Installation (page 0063 00-3).

INITIAL SETUP:

Maintenance Level

Operator

Equipment Condition

Engine stopped (WP 0023 00)

Carrier blocked (WP 0038 00)

Materials/Parts

Liquid soap (WP 0083 00, Item 17)

Personnel Required

Driver

REMOVAL

1. Unlatch four clamps holding the element container to the air cleaner head. Support the container so it doesn't drop.
2. Remove the container with the element inside.
3. Remove the element from the container.

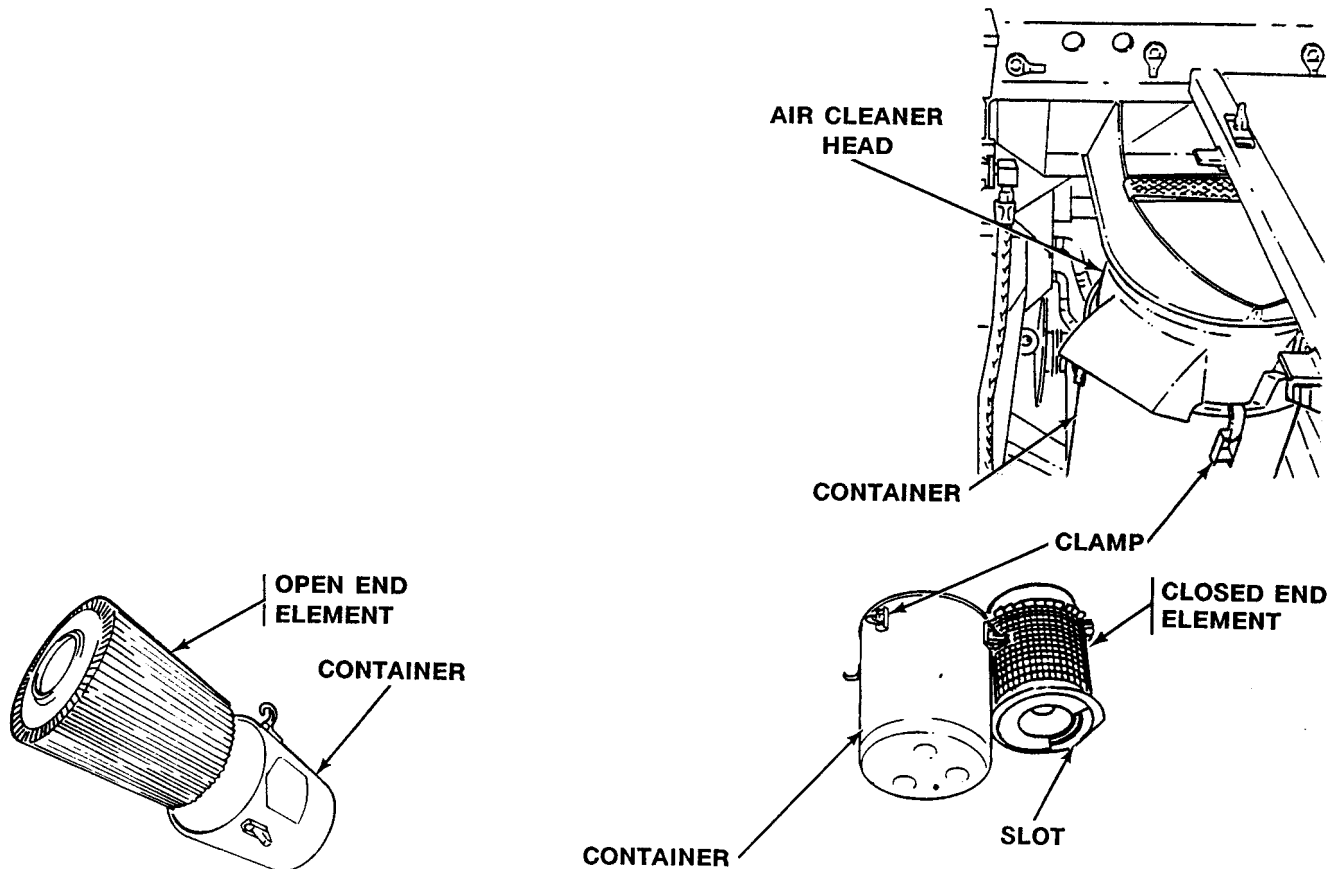

CLEANING

WARNING

DO NOT clean the air cleaner element using gasoline or petroleum solvent.

CAUTION

Go easy so you don't damage the element. Don't hit or drop the element on its ends.

NOTE

You can clean the air cleaner element anytime by jarring it to knock dirt loose. If you don't have to use the carrier for a few hours, you can wash the element with soap and water. You can blow the filter clean if you have access to compressed air.

1. Clean by jarring.
 - a. To clean an open end element tap the fins gently with your hands, then tap the sides to knock dirt out.
 - b. To clean a closed end element tap the sides gently with your hands.

CAUTION

Dry the air cleaner element before you put it back in the carrier. If you try to drive with a wet element, you'll end up with an air cleaner full of mud and a carrier that won't go.

2. Clean with soap and water.
 - a. Wash the element with warm water and liquid soap.
 - b. Make sure the element is dry before you put it back in the carrier.

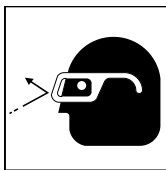
WARNING

Air pressure in excess of 30 psi (207 kPa) can injure personnel. Do not direct pressurized air at yourself or others. Always wear goggles.

3. Clean with compressed air.
 - a. To clean an open end element direct 100 psi (690 kPa) compressed air through the element from inside to outside, down the outside all around, and inside to outside again.
 - b. To clean a closed end element direct 100 psi (690 Pa) compressed air through the element from inside to outside.

INSTALLATION

CAUTION

Two non-interchangeable air cleaner types are used on M548A1 carriers. Make sure you install the right element and container. An air cleaner container with stops inside requires a closed end element.

1. To install an open end element, just slide it back into the container. It doesn't matter which end goes in first.
2. To install a closed end element, put it in the container with the closed end down and turn the element until the slot on the bottom is between the stops in the container.
3. Hold the container under the air cleaner head and latch the four clamps.

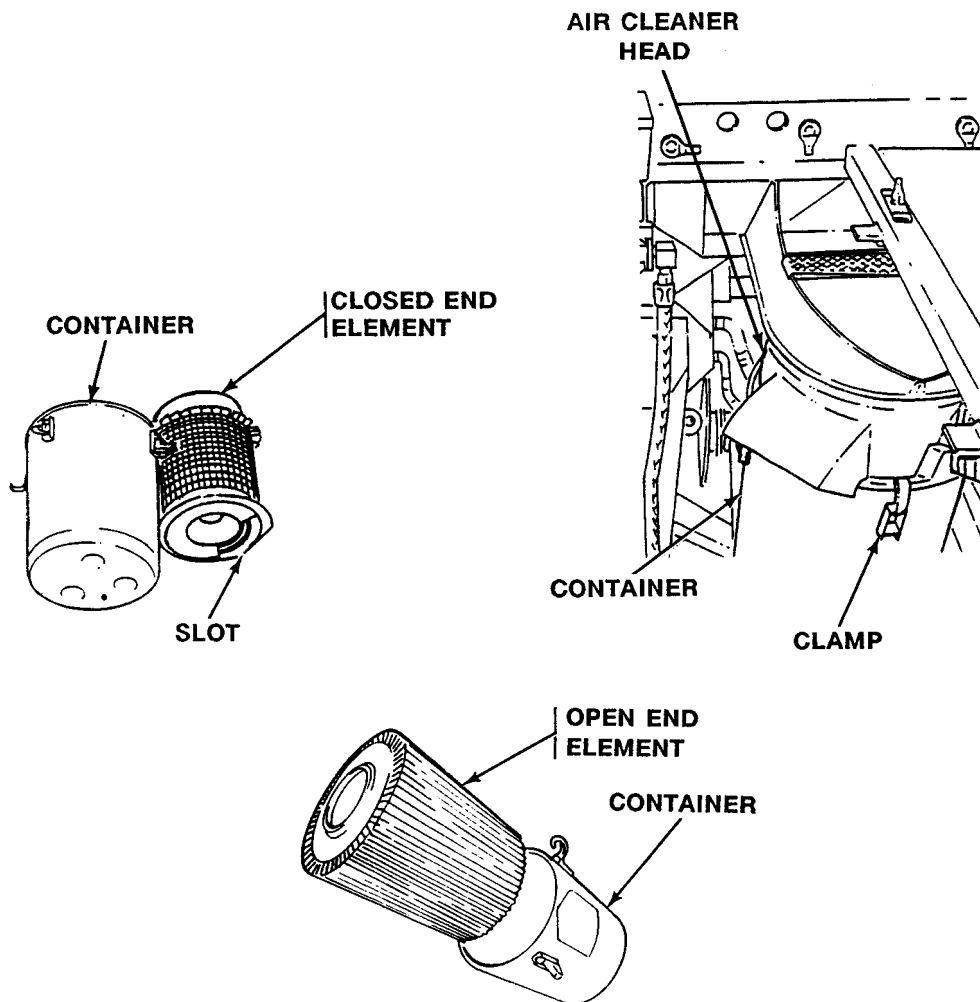

END OF TASK

REMOVE/INSTALL AIR CLEANER ELEMENT DOOR (M548A3)

0064 00

THIS WORK PACKAGE COVERS:

Removal (page 0064 00-1).
 Installation (page 0064 00-2).

INITIAL SETUP:

Maintenance Level

Operator

Equipment Condition

Engine stopped (WP 0024 00)

Personnel Required

Driver

REMOVAL

WARNING

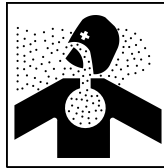

DO NOT service air cleaner or vent system after NBC attack until carrier has been decontaminated. Before doing this task, read NBC warnings in Summary of Warnings at beginning of this manual.

CAUTION

DO NOT operate carrier if air cleaner element is missing or air cleaner housing door gasket is missing or damaged. Extensive engine damage will result.

1. Enter carrier cab. Raise center seat.
2. Release latch at top of air cleaner housing. Swing door up and remove door.
3. Check door for missing or damaged seal.

NOTE

DO NOT remove air cleaner element unless instructed by unit maintenance.

4. Ensure air cleaner element is present.

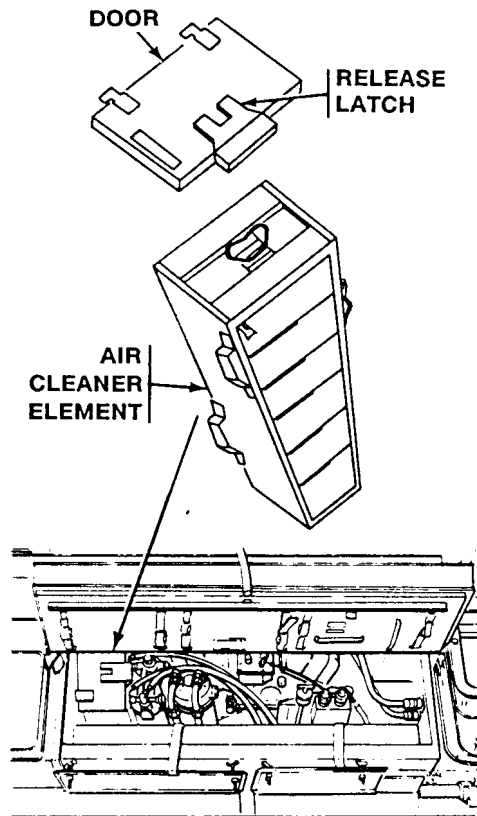
**INSTALLATION**

1. Install door on air cleaner housing and secure latch.
2. If element has been cleaned, press rubber dome on air cleaner restriction indicator to reset indicator.
3. Lower center seat.

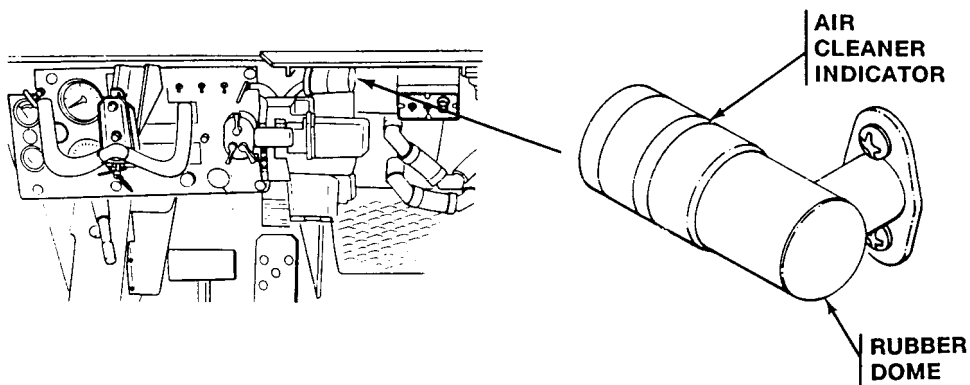
**END OF TASK**

CHECK/FILL COOLING SYSTEM (M548A1)

0065 00

THIS WORK PACKAGE COVERS:

Operational Check (page 0065 00-1).

INITIAL SETUP:

Maintenance Level

Operator

Materials/Parts

Antifreeze (WP 0083 00, Item 2)

Personnel Required

Driver

References

FM 9-207

TB 750-651

Equipment Condition

Engine stopped (WP 0023 00)

OPERATIONAL CHECK

WARNING

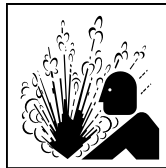

Hot radiator coolant can burn you. Use hand to remove cap only if cool to touch. Turn cap slowly to release pressure. Replace cap by pressing down and turning cap until tight.

CAUTION

Adding coolant to an overheated engine could damage engine. Do not add coolant to an overheated engine unless engine is running.

NOTE

Approved antifreeze coolant only may be added to radiator. In an emergency, water may be added if specified coolant is not available.

1. Remove radiator cap.

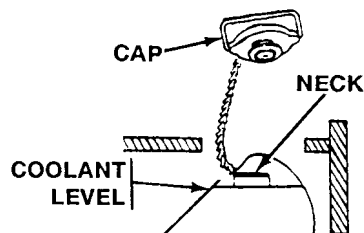

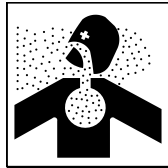
WARNING

Engine exhaust fumes can kill you. Do not operate the carrier with access panels off. Make sure the panels are sealed tight. See warning in the front of this manual.

2. Check coolant level. Coolant should reach bottom of filler neck. Add coolant as needed. After adding coolant, start and idle engine for 5 minutes and check coolant level again.

CAUTION

Use local ground water as coolant ONLY as a last resort. It may contain dirt or minerals that can damage the cooling system.

3. If water was added, ask unit maintenance to check antifreeze protection level.
4. Install radiator cap.

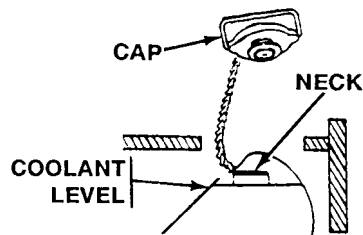

END OF TASK

CHECK/FILL COOLING SYSTEM (M548A3)

0066 00

THIS WORK PACKAGE COVERS:

Operational Check (page 0066 00-2).

INITIAL SETUP:

Maintenance Level

Operator

Personnel Required

Driver

References

FM 9-207

TB 750-651

Equipment Condition

Engine stopped (WP 0024 00)

OPERATIONAL CHECK

WARNING

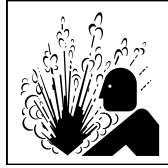

Hot radiator coolant can burn you. Use hand to remove cap only if cool to touch. Turn cap slowly to release pressure. Replace cap by pressing down and turning cap until tight.

CAUTION

Adding coolant to an overheated engine could damage engine. Do not add coolant to an overheated engine unless engine is running.

Local ground water may contain dirt or minerals that can damage the cooling system. Use clean water, preferably distilled water for cooling system replacement water.

1. Remove coolant fill cap.
2. Check coolant level. Coolant should reach bottom of filler neck. Add coolant as needed. After adding coolant, start and idle engine for 5 minutes and check coolant level again.
3. Install coolant fill cap.

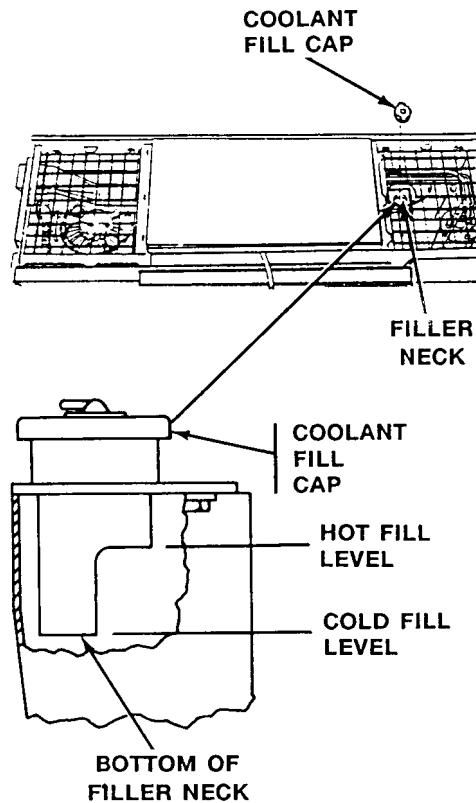

END OF TASK

CHECK DRIVE BELTS TENSION (M548A1)

0067 00

THIS WORK PACKAGE COVERS:

Check Drive Belts (page 0067 00-1).

INITIAL SETUP:

Maintenance Level

Operator

Equipment Condition

Engine stopped (WP 0023 00)

Personnel Required

Driver

OPERATIONAL CHECK

CHECK DRIVE BELTS

WARNING



DO NOT try to check drive belt tension with the engine running. Serious injury to personnel can result.

1. Raise center seat (WP 0011 00).
2. Check coolant pump drive belts.
 - a. Depress drive belt halfway between pulleys. If drive belt moves more than 3/8 inch (1 cm), it needs tightening. Notify unit maintenance.
3. Lower center seat (WP 0011 00).

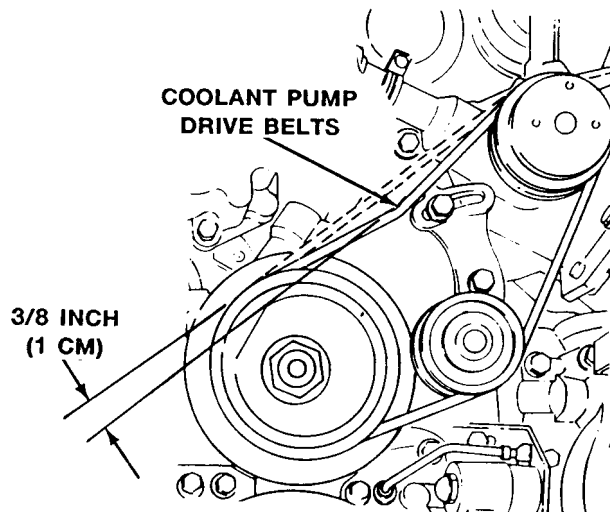

4. Open power plant rear access panels (WP 0036 00).

CHECK DRIVE BELTS TENSION (M548A1) — Continued**0067 00**

5. Check generator drive and fan drive belts.
 - a. Find the lower end of each belt idler adjusting rod inside slot on adjuster.
 - b. If lower end of each belt idler adjusting rod is not between adjustment marks, drive belt needs adjustment. Notify unit maintenance.

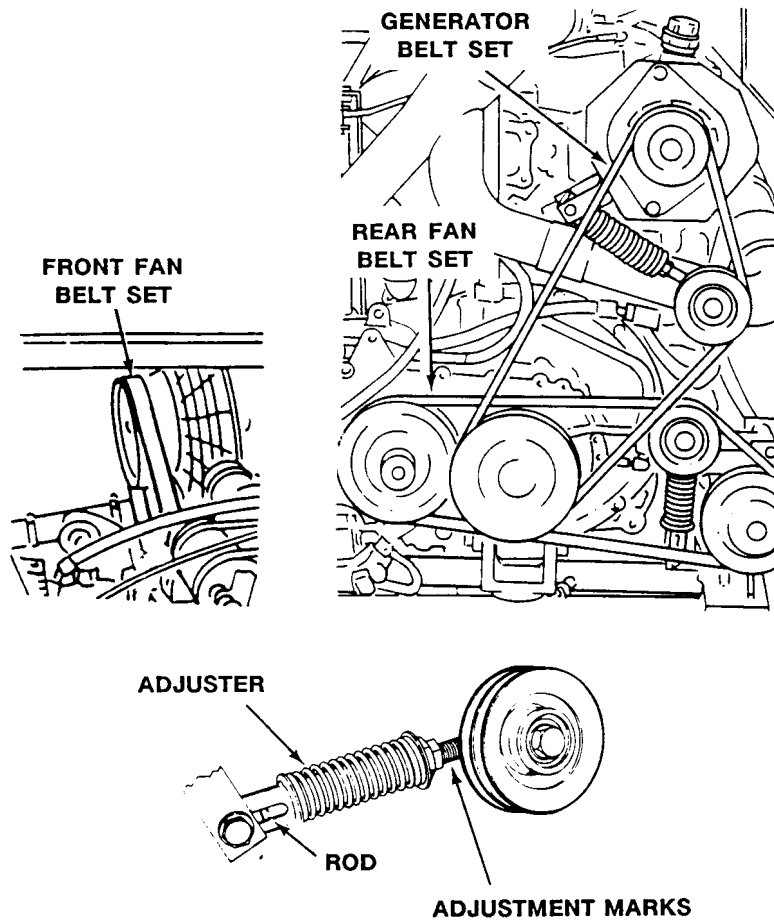

6. Close power plant rear access panels (WP 0036 00).

END OF TASK

CHECK DRIVE BELTS TENSION (M548A3)

0068 00

THIS WORK PACKAGE COVERS:

Check Drive Belts (page 0068 00-1).

INITIAL SETUP:

Maintenance Level

Operator

Equipment Condition

Engine stopped (WP 0024 00)

Personnel Required

Driver

OPERATIONAL CHECK

CHECK DRIVE BELTS

WARNING



DO NOT try to check drive belt tension with the engine running. Serious injury to personnel can result.

1. Remove power plant rear access panel (WP 0036 00).

NOTE

Notify unit maintenance if tension of any drive belt needs adjustment.

2. Check the coolant pump drive belts.
 - a. Depress drive belt halfway between pulleys. If drive belt moves more than $\frac{3}{8}$ inch (1 cm), belt needs tightening.
3. Check the generator drive belts.
 - a. Depress drive belt halfway between pulleys. If drive belt moves more than $\frac{3}{8}$ inch (1 cm), belt needs tightening.

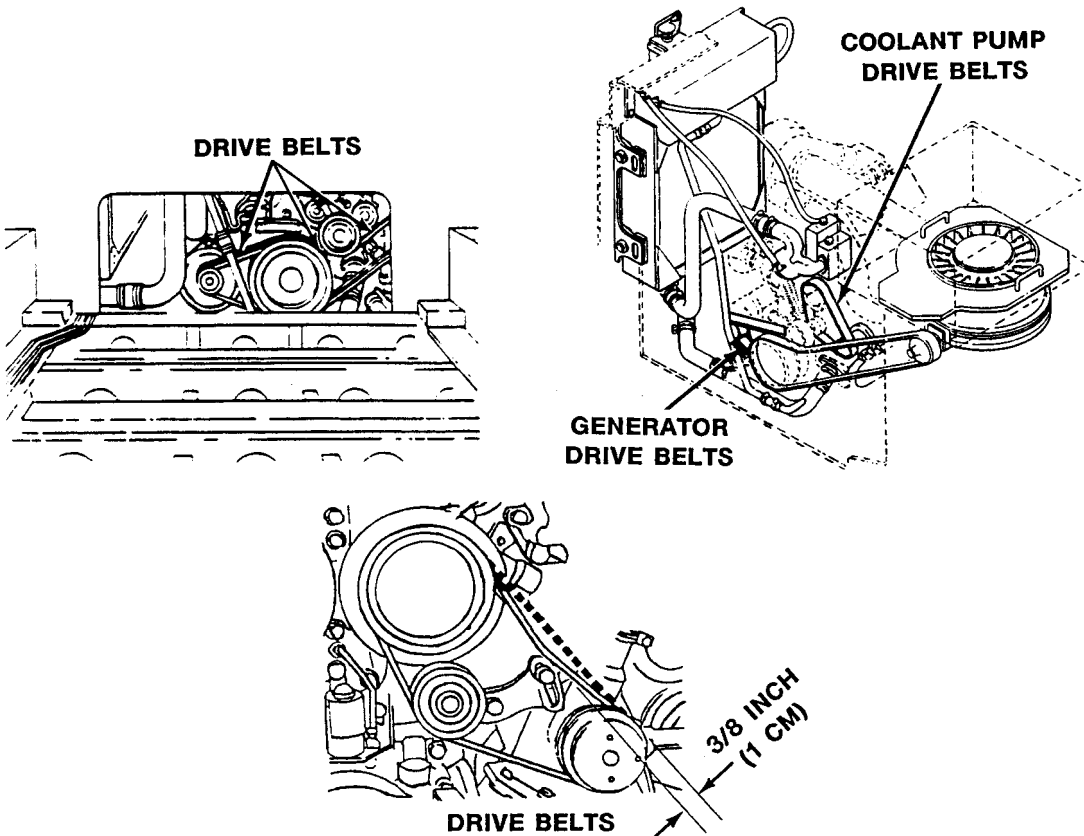

4. Check the coolant fan drive belts.
 - a. Find the lower end of fan idler adjusting nut (rod) inside slot on adjusting sleeve.
 - b. If lower end of fan idler adjusting nut (rod) is not between operating range marks, drive belt needs adjustment.

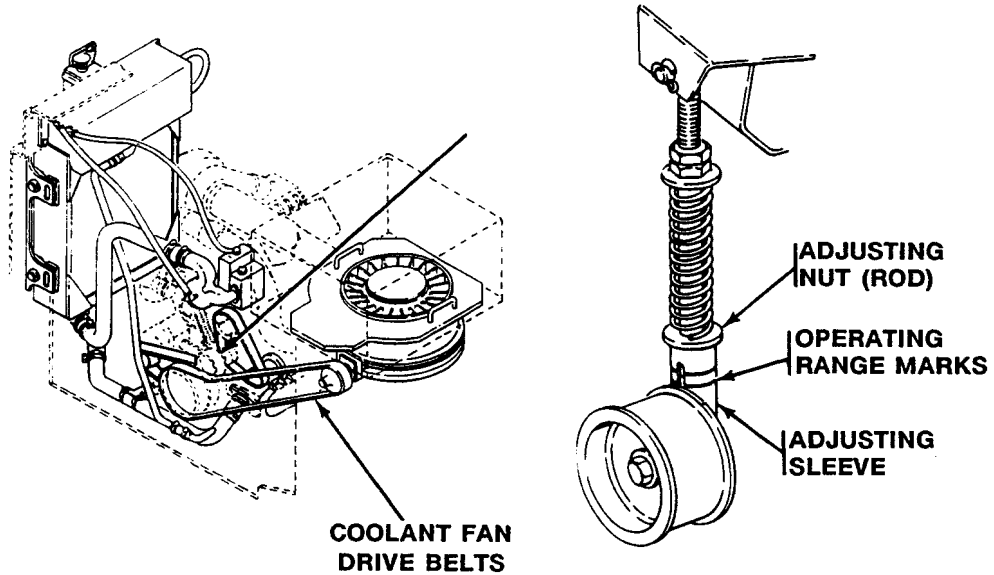

5. Install power plant rear access panel (WP 0036 00).

END OF TASK

DRAIN FUEL FILTERS AND AIR SEPARATOR TANK

0069 00

THIS WORK PACKAGE COVERS:

Drain Fuel Filters and Air Separator Tank (page 0069 00-1).

INITIAL SETUP:

Maintenance Level

Operator

Personnel Required

Driver

Materials/Parts

Wiping rag (WP 0083 00, Item 16)
Container

Equipment Condition

Engine stopped (WP 0023 00), (WP 0024 00)
Master switch ON

SERVICING

DRAIN FUEL FILTERS AND AIR SEPARATOR TANK

WARNING



Fuel can catch fire and burn you. Do not smoke or allow open flame near carrier when draining fuel system filters.

CAUTION

Open drain valves and drain cocks slowly so you don't spray fuel all over the power plant. If you spill fuel, wipe it up to avoid fire.

NOTE

The M548A1 has two drain valves and the M548A3 has one drain valve and one drain cock.

1. Hold a container under each drain valve or drain cock.

2. Slowly open each drain valve or drain cock and let it run until the all debris and water is washed away.

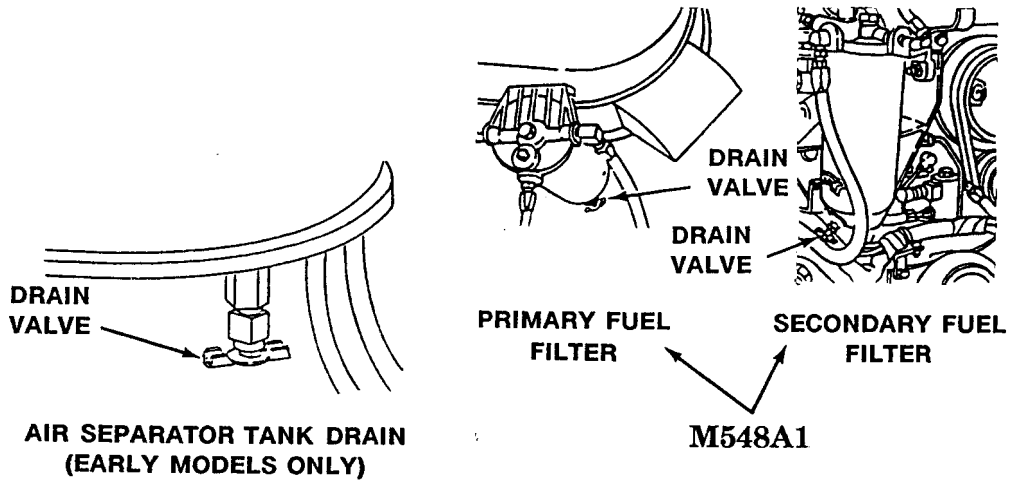

3. When clean fuel starts to run, close the drain valve or drain cock.

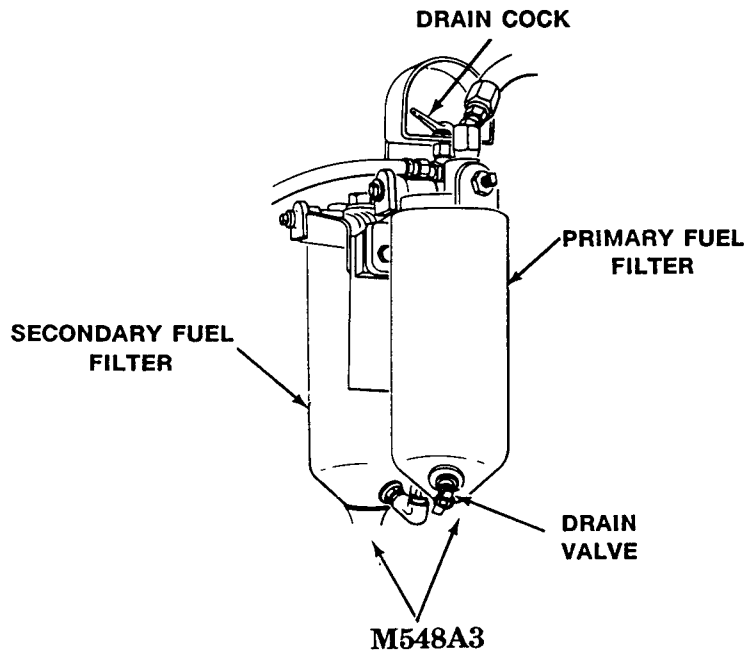

END OF TASK

MAINTENANCE OF BATTERIES

0070 00

THIS WORK PACKAGE COVERS:

Maintenance of Batteries (page 0070 00-2).

INITIAL SETUP:

Maintenance Level

Operator

References

TM 9-6140-200-14

Tools and Special Tools

Flashlight (WP 0083 00, Item 11)

Equipment Condition

Engine stopped (WP 0023 00), (WP 0024 00)

Carrier blocked (WP 0038 00)

Materials/Parts

Grease (GAA) (WP 0083 00, Item 14)

Wiping rag (WP 0083 00, Item 16)

Personnel Required

Driver

SERVICING

MAINTENANCE OF BATTERIES

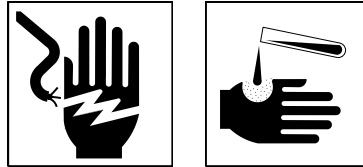
WARNING

Battery posts and cables touched by metal objects can short circuit and burn you or injure you. Use caution when you work with tools or other metal objects. Do not wear jewelry when you work on electrical system.

Take care not to get electrolyte or battery corrosion on your clothes or skin. If you do get some on you, wash it off with lots of water. If you get electrolyte or corrosion in your eyes, rinse your eyes with lots of water and get to a medic right away.

NOTE

One set of batteries is located on the left side of carrier under driver's seat. The M548A3 has another set located on right side of carrier under the passenger seat. Be sure to perform maintenance on both sets of batteries.

1. Release the seat latch behind the left (driver's) seat and raise the seat to get to the batteries.

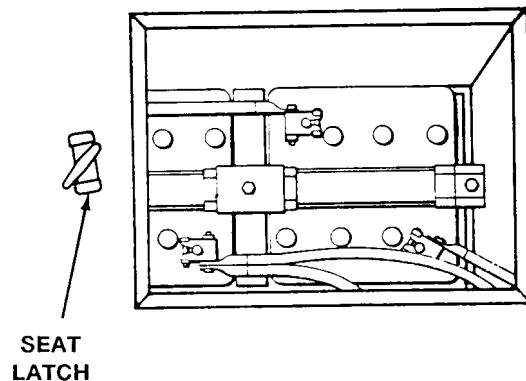

2. Terminal connectors should be tight and all the way down on the battery posts.
3. Battery retainers should be tight enough to keep the batteries from slipping and sliding, but not so tight they crack the case.
4. Cover connectors with a light coat of grease (GAA) to prevent corrosion. If any nuts or screw threads are corroded so bad they won't hold, notify unit maintenance.
5. Check battery cables for loose or broken connections.

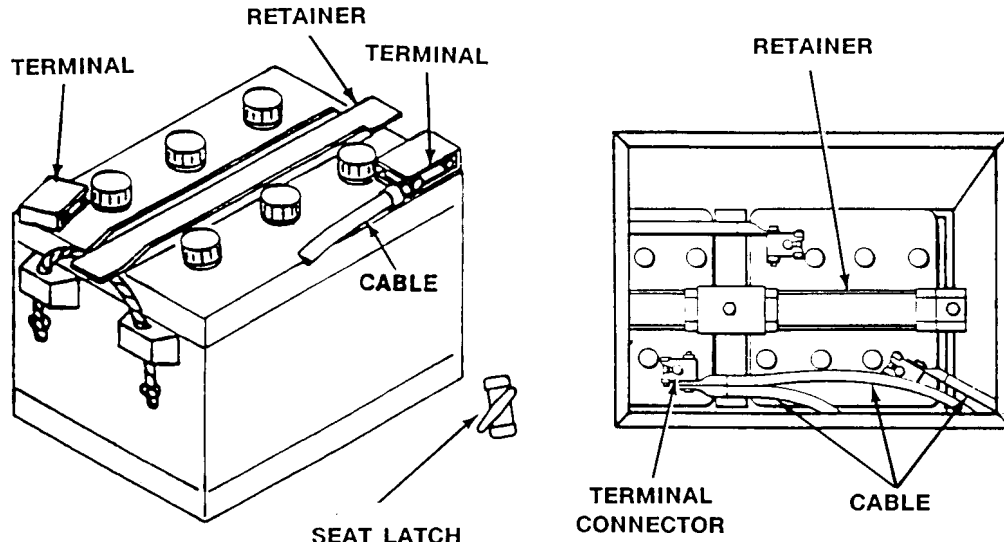

WARNING

Take care not to get electrolyte or battery corrosion on your cloths or skin. If you do get some on you, wash it off with lots of water. If you get electrolyte or corrosion in your eyes, rinse your eyes with lots of water and get to a medic right away.

NOTE

If you don't have distilled water, use clean rain water. Bottled drinking water is your third choice, if you don't have anything else. The mineral salts in ground water can destroy your batteries in no time. Don't keep battery water in a metal container.

Check the electrolyte level more frequently in hot weather.

6. Remove vent plugs from batteries and check battery electrolyte level. Use a flashlight. Look down into each battery cell. The electrolyte level should be covering the plates and to the lower edge of the vent. If battery cells are low or dry, add distilled water. Check that vent holes are clear in caps (plugs) before installation. Install vent plugs on battery cells.

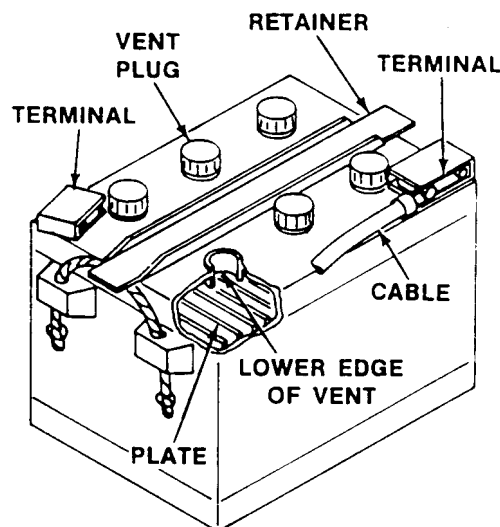

7. Clean battery. Wipe off battery casing and surrounding metal parts. Use clean dry wiping rag. Check terminals, clamps, cables, and retainers for corrosion. If wiping rag will not remove dirt, notify unit maintenance.
8. If the temperature is below -40°F (-40°C), charge the batteries right after adding water. Charging will mix the water with the electrolyte and reduce the chance of the batteries freezing.
9. On M548A3 carriers repeat Steps 1 - 8 for right (passenger) side batteries.
10. Lower the seat and latch it securely.
11. For more information on batteries, see TM 9-6140-200-14.

END OF TASK

MAINTENANCE OF CARGO COVER

0071 00

THIS WORK PACKAGE COVERS:

- Removal of Cargo Cover (page 0071 00-1).
- Installation of Cargo Cover (page 0071 00-3).
- Closure Flaps (page 0071 00-5).
- Escape Hatch Cover (page 0071 00-6).

INITIAL SETUP:

Maintenance Level

Operator

Equipment Condition

Engine stopped (WP 0023 00), (WP 0024 00)

Personnel Required

Driver
Soldier

REMOVAL

1. Unbuckle six outside web straps (three front and three rear) holding the front and rear flaps closed.
2. Untie six inside ties holding the front and rear flaps closed.
3. Loosen the right and left tie down ropes and the two rear tie down ropes. Then unhook the ropes from the tie down cleats.

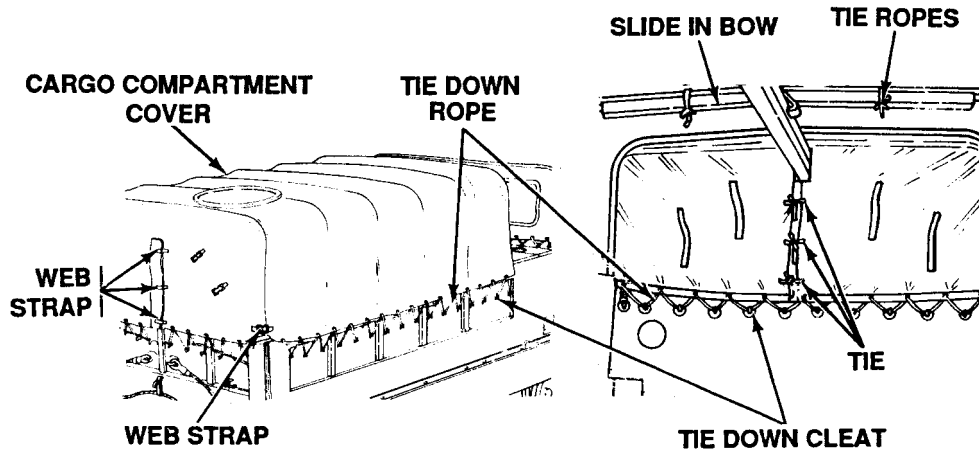

4. Unbuckle two web straps at each rear corner of the cargo compartment cover.
5. Loosen the front tie down rope and unhook it from the cleats on the power plant compartment bulkhead.
6. Untie nine tie ropes holding the cargo compartment cover to the four center bows.

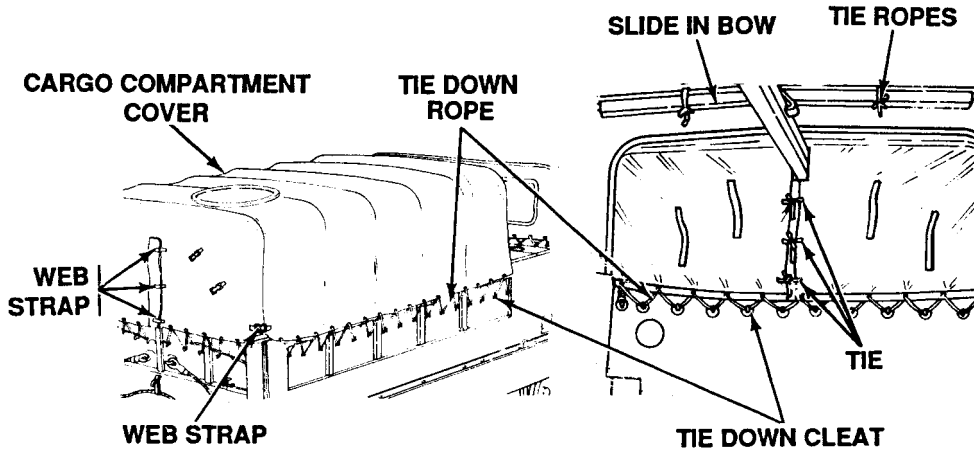

CAUTION

Make sure the cargo compartment cover is clean and dry before you put it away. If you store it wet or dirty, rot or mildew could ruin it.

7. Take off the cargo compartment cover, fold it up, and stow it away.
8. Take out the three rear slide in bows and stow them in the slots between the front slide in bow and the front support bow.
9. If you don't have the material handling kit, take out four screws, flat washers, and rubber washers, and two rubber pads holding the rear support bow in place.
10. Move the rear support bow to the stowage position right behind the front slide in bow, and fasten it with two rubber pads, four rubber washers, flat washers, and screws.

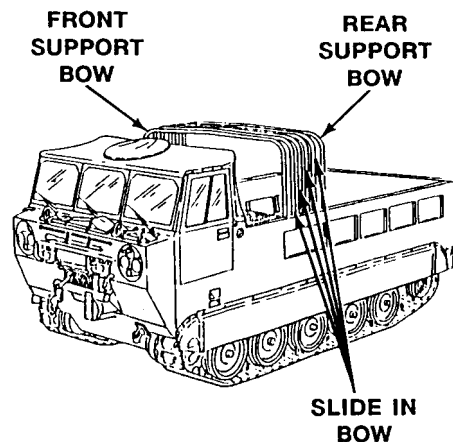

INSTALLATION

1. If the rear support bow is stowed at the front of the cargo compartment, put it back where it belongs. Take out four screws, flat washers, rubber washers, and two rubber pads.
2. Position the rear support bow at the rear of the cargo compartment and fasten it with two rubber pads, four rubber washers, flat washers, and screws.
3. Move the three rear slide in bows from the stowage slots to their regular positions.

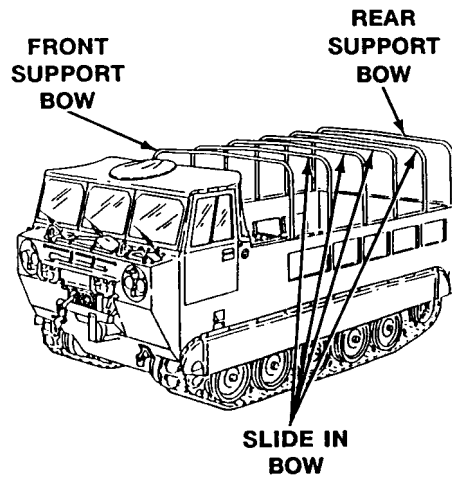
**CAUTION**

Make sure the cargo compartment cover is clean and dry before you install it. Notify unit maintenance if it is wet, dirty, mildewed, or rotted.

4. Pull the cargo compartment cover into position over the bows. Make sure the escape hatch is at the right rear.
5. Fasten the cargo compartment cover to the four center bows with its nine attached tie ropes.

6. Buckle six web straps (three front and three rear) to hold the front and rear flaps closed.

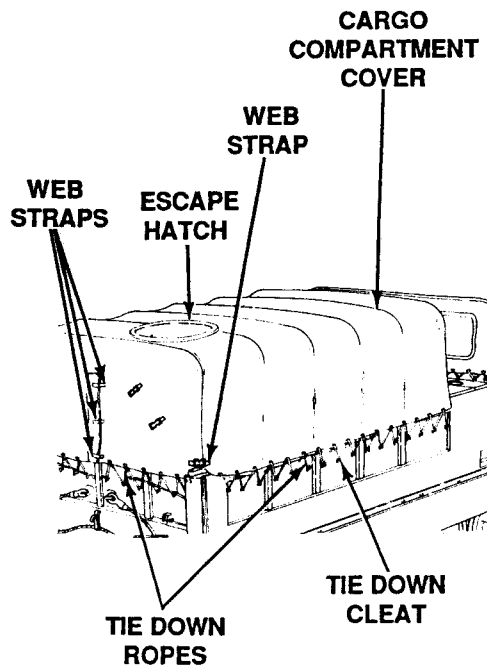

7. Hook the right and left tie down ropes onto the tie down cleats. (There are 16 cleats on each side.) Tighten the ropes, starting at the front and working back, so the cargo compartment cover is tight and the sides are about even. Then tie the ropes in place.
8. Hook the front tie down rope to 12 cleats on the power plant compartment bulkhead. Tighten the rope and tie it in place.
9. Lead one web strap at each rear corner under the cargo compartment door hinges. Then buckle two web straps at each rear corner of the cargo compartment cover.
10. Hook the two rear tie down ropes to the cleats on the cargo compartment door (six cleats per rope). Tighten the ropes and tie them in place.

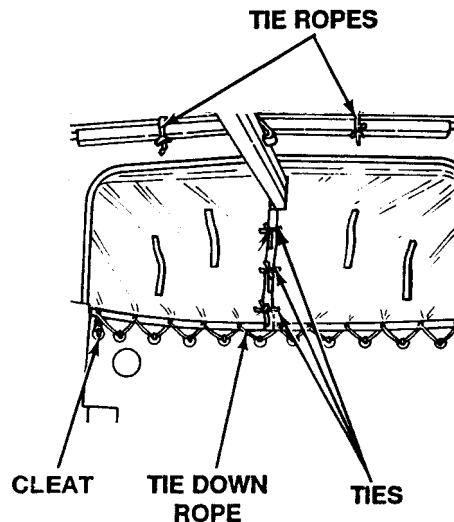

CLOSURE FLAPS

CAUTION

To keep front closure flaps from getting burned on engine or heater exhaust pipes, always roll flaps inward and use tie down rope to pull rolls tight.

1. Open the flaps; unfasten tie down ropes from cleats, roll flaps up on a slant and fasten the rolls with the outside flap buckles and inside flap straps (two per flap). Always roll the front flaps toward the inside, and use the tie down rope to fasten the end eyelets to the end cleats on the power plant compartment bulkhead.
2. Close the flaps; unbuckle the flap straps and secure the flaps closed (Installation of Cargo Cover Procedure Step 6, Step 8, and Step 10).

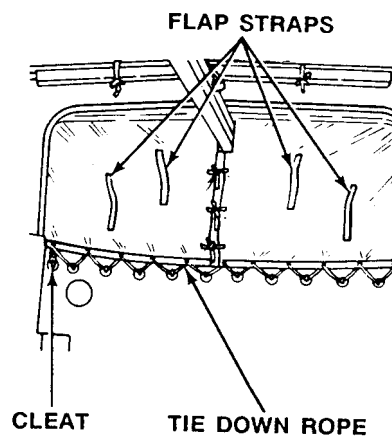

ESCAPE HATCH COVER

1. Open the escape hatch cover, push up on its front edge until the cover spring slips off the retaining ring. A retainer at the rear keeps the hatch cover attached to the cargo compartment cover.
2. Close the escape hatch cover, stretch the cover spring around the lip of the retaining ring.

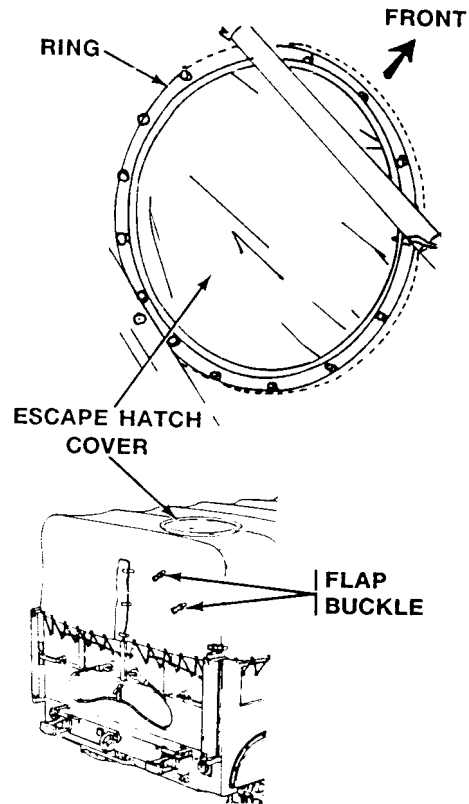
**END OF TASK**

MAINTENANCE OF CAB COVER AND WINDOWS

0072 00

THIS WORK PACKAGE COVERS:

- Removal of Cab Cover (page 0072 00-1).
- Installation of Cab Cover (page 0072 00-2).
- Escape Hatch Cover (page 0072 00-2).
- Window Stowage (page 0072 00-3).
- Remove/Install Windshield Sections (page 0072 00-3).
- Remove/Install Cab Side Windows (page 0072 00-4).

INITIAL SETUP:

Maintenance Level

Operator

Equipment Condition

Engine stopped (WP 0023 00), (WP 0024 00)
 Carrier blocked (WP 0038 00)

Personnel Required

Driver
 Soldier

REMOVAL

1. Loosen the tie down rope and unhook the rope from the cleats at the back of the cab.
2. Unsnap the sides of the cab cover from the cab frame. (There are 12 snaps around each side window.)
3. Pull the cab cover clear of the cab frame and slide the cover to one side. This will pull a rope bead at the front of the cover out of a groove in the cover mount.

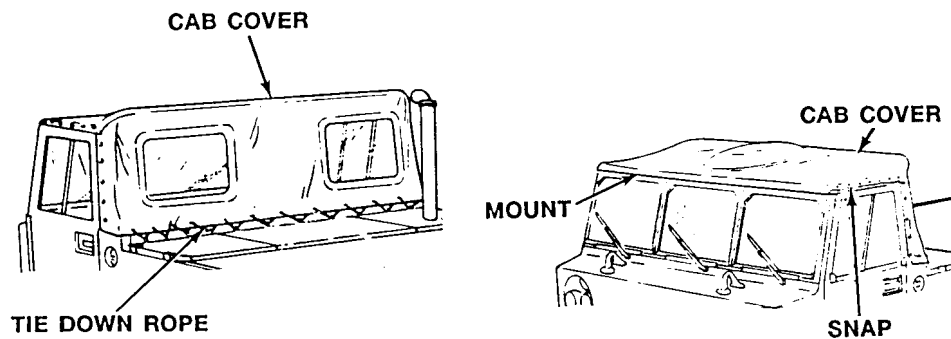

CAUTION

Take care not to damage the escape hatch ring or the plastic rear windows. Make sure the cover is clean and dry. If you put it away wet or dirty, rot or mildew could ruin it.

4. Fold and stow the cover.

INSTALLATION

CAUTION

Make sure that the escape hatch ring or the plastic rear windows are not damaged, and that the cab cover is dry and free of dirt, mildew, and rot.

1. Unfold the cab cover and guide the rope bead into the groove in the cover mount. Then pull the cover sideways until it's in position over the cab.
2. Spread the cab cover over the cab frame. Pull the cover tight across the front, so the cloth is smooth along the mount, and snap the sides of the cab cover to the cab frame.
3. Hook the tie down rope to the 12 cleats at the back of the cab. Tighten the rope and tie it in place.

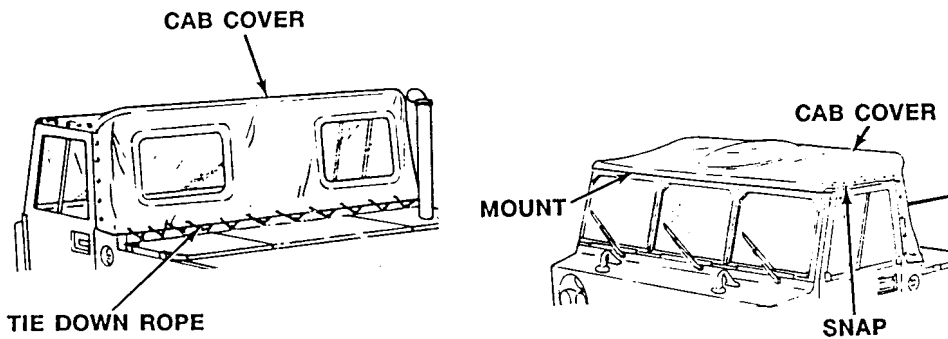

ESCAPE HATCH COVER

1. The cab escape hatch cover works exactly the same as the cargo compartment escape hatch cover. See the picture and instructions in WP 0071 00. The cab escape hatch cover has a retainer at the rear that keeps it fastened to the cab cover when you open it.

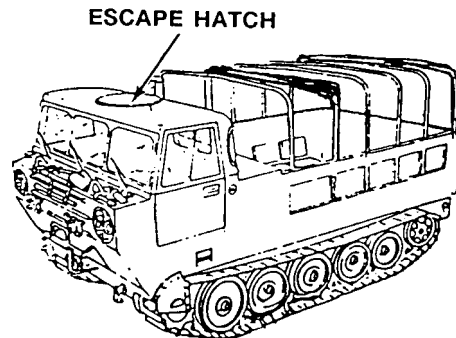

WINDOW STOWAGE

1. Whenever you remove a windshield section or cab side window, stow it in the window bag. Keep the window bag strapped down to the top deck panel.

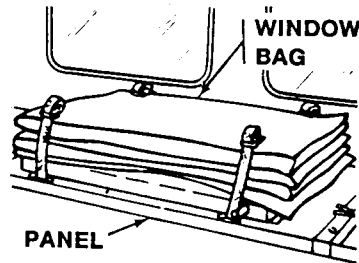
**REMOVE/INSTALL WINDSHIELD SECTIONS****CAUTION**

To avoid the chance of being hurt by broken glass, remove all the windshield sections in a combat area.

NOTE

The windshield sections on your carrier are fastened with inside locking studs or with outside T-bolts. If your carrier has inside locking studs, turn the stud handles counterclockwise to unlock them when you remove a windshield section. Turn the handles clockwise to lock the studs after you install a windshield section. If your carrier has outside T-bolts, unscrew the T-bolts so you can remove a windshield section. When you install a windshield section, screw the T-bolts in to secure the section in place.

1. To remove a windshield section, unlock the locking studs or T-bolts and lift the windshield section out of the retaining strip. Follow instructions on page 0072 00-3 to stow windshield sections.

- To install a windshield section, set it in the retaining strip and lock the studs or tighten the T-bolts to secure the windshield section in place.

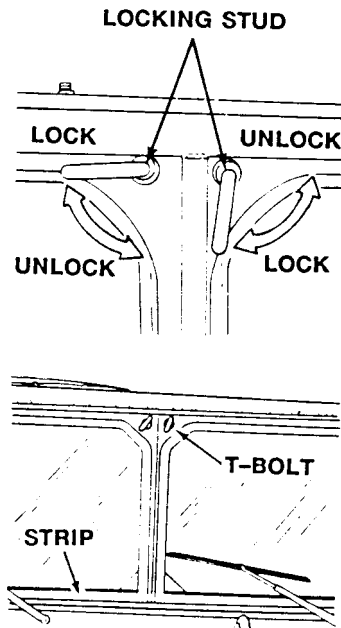

REMOVE/INSTALL CAB SIDE WINDOWS

CAUTION

To avoid the chance of being hurt by broken glass, remove all the cab side windows in a combat area.

NOTE

Each cab side window is held to its cab door by two screws and flat washers. One screw and washer are in the handle recess on the outside of the door, and the other screw and washer are in a recess on the inside of the door, just above the upper hinge.

- To remove a side window, open the door and remove two screws and washers.
- Lift the window straight up until the window locating pins are clear of the door.

3. Stow the side window in the window bag (page 0072 00-3).

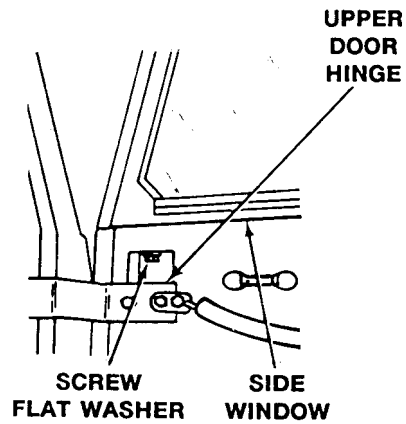

NOTE

Make sure you match the doors and windows, left and right. The sliding panel has to be at the rear, and the window control has to be on the inside.

4. To install a side window; open the door, line up the window locating pins with the sockets in the top of the door, and ease the window down into place.
5. Secure the window in place with two washers and screws.

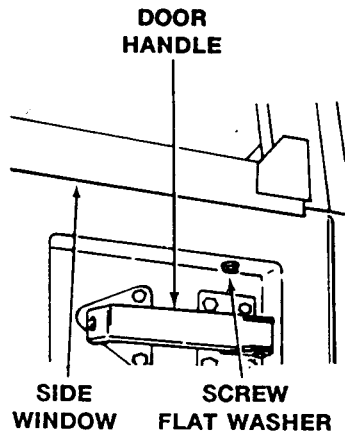

END OF TASK

SERVICE BILGE PUMP

0073 00

THIS WORK PACKAGE COVERS:

- Clean (page 0073 00-1).
- Check Operation (page 0073 00-2).

INITIAL SETUP:

Maintenance Level

Operator

Equipment Condition

- Engine stopped (WP 0023 00), (WP 0024 00)
- Cab center floor plates raised (M548A1) (WP 0077 00)
- Hull bottom access cover removed (M548A3) (WP 0076 00)

Tools and Special Tools

- Cross Tip Screwdriver (WP 0081 00, Item 33)
- Flashlight (WP 0083 00, Item 11)

Personnel Required

- Driver
- Helper (H)

SERVICING

CLEAN

NOTE

The bilge pump on the M548A1 is located in the right front corner of the power plant compartment. On the M548A3, the pump is located in the rear center of the engine compartment. The screens and vent holes are maintained in the same way.

The pump has an inlet screen to keep the pump from swallowing junk that could jam or break the pump. But if the screen gets blocked (with big leaves, paper, cardboard and other debris) the pump can't suck any water.

1. Clear away any trash on the inlet screen. Keep the carrier bilge cleaned out.

NOTE

The bilge pump has a vent hole that you need to keep clean. If the vent hole gets clogged, the pump could become air locked.

2. Clean the vent hole by running a wire back and forth a few times.

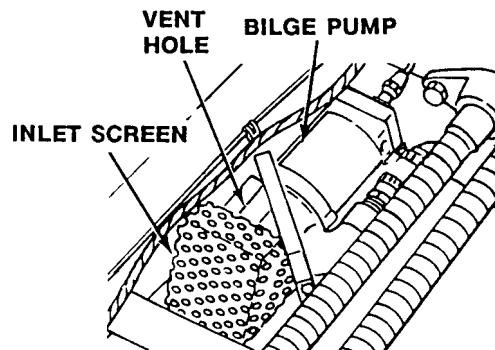

CHECK OPERATION

1. Move MASTER SWITCH to ON.

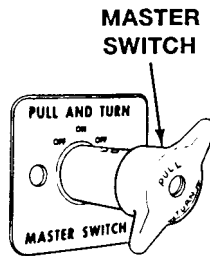

2. Move BILGE PUMP switch to ON.

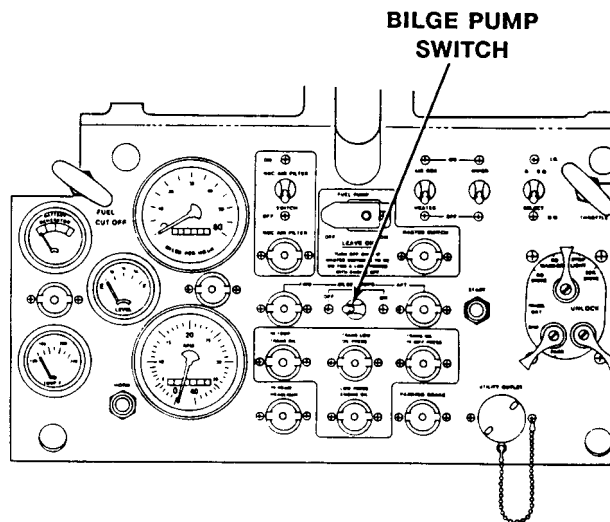

3. (H) Check for air flow at right side bilge pump outlet.
4. Move BILGE PUMP switch to OFF.
5. Move MASTER SWITCH to OFF.
6. Notify unit maintenance if bilge pump is faulty.

END OF TASK

MAINTENANCE OF MACHINE GUN RING MOUNT ASSEMBLY (M66)

0074 00

THIS WORK PACKAGE COVERS:

Adjustment of Equilibrator Spring (page 0074 00-1).

INITIAL SETUP:

Maintenance Level

Operator

Personnel Required

Driver

Tools and Special Tools

Adjustable Wrench (WP 0081 00, Item 43)

Equipment Condition

Engine stopped (WP 0023 00), (WP 0024 00)

ADJUSTMENT

NOTE

The only maintenance the machine gun ring (M66) may require is an occasional adjustment of the equilibrator spring.

1. Make sure the travel lock pin is in place.
2. Check the machine gun with ammunition balance.
3. Use your adjustable wrench to hold the equilibrator case in position.
4. Take out the screw and washer, and loosen or tighten the equilibrator spring using the wrench.
5. Move the equilibrator case until the new hole you want is lined up with the threaded hole in the cradle. Install the washer and screw.
6. Repeat as necessary, until the machine gun and ammunition are pretty well balanced.

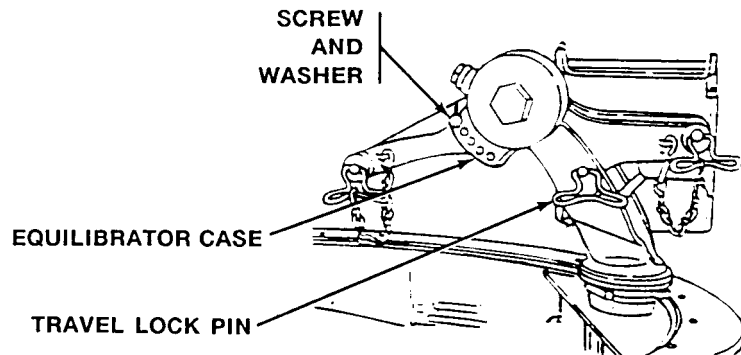

END OF TASK

MAINTENANCE OF AIR BRAKE KIT (M548A1)

0075 00

THIS WORK PACKAGE COVERS:

- Air Couplings (page 0075 00-1).
- Treadle Valve Pedal (page 0075 00-2).
- Instrument Panel (page 0075 00-2).
- Air Reservoir (page 0075 00-3).
- Compressor Drive Belts (page 0075 00-3).

INITIAL SETUP:

Maintenance Level

Operator

Equipment Condition

Carrier stopped
 Engine started (WP 0013 00)

Tools and Special Tools

Required: Flashlight (WP 0083 00, Item 11)

Personnel Required

Driver

INSPECTION-ACCEPTANCE AND REJECTION CRITERIA

AIR COUPLINGS

NOTE

Except when the air brake couplings are connected to a towed load, make sure they are stowed properly.

1. Cutoff cocks closed (open if connected to a towed load).
2. Dummy couplings installed (unless hoses are connected to a towed load).
3. Inspect the hoses and couplings for damage or bad wear. If you find any damage, notify unit maintenance.

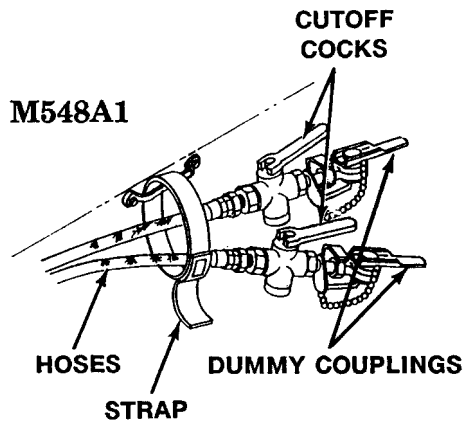

TREADLE VALVE PEDAL

1. Move the pedal and check for binding. The spring must return the pedal and valve to the closed position when you release the pedal.
2. Look for signs of spring damage. If you find any, notify unit maintenance.

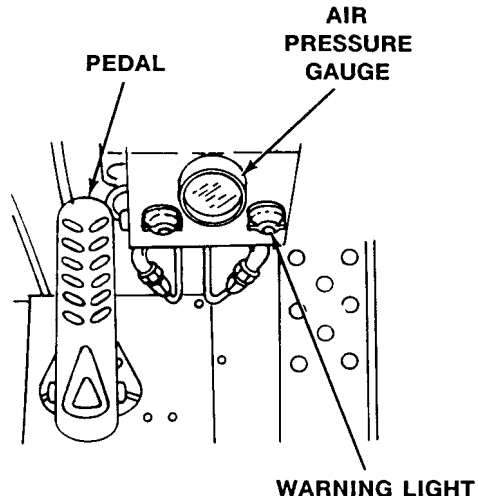
**INSTRUMENT PANEL****NOTE**

With the engine running, pressure should build up and stay between 85 and 105 psi (586 to 724 kpa). If you are using the air brakes with a towed load, make sure the compressor keeps the pressure above 85 psi (586 kpa).

1. Check the air pressure gauge. If it reads below 60 psi (414 kpa), the warning light must be on.

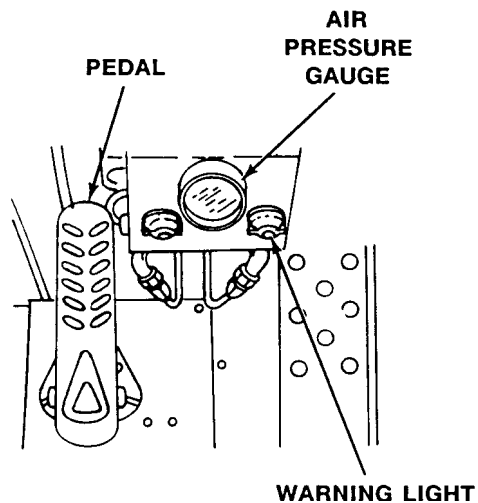

AIR RESERVOIR

1. Place a suitable container under the drain cock and drain water out of the air reservoir.
2. Unscrew the drain cock until water runs out.
3. Screw the drain cock closed when water stops running.

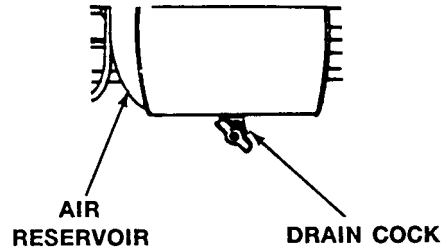
**COMPRESSOR DRIVE BELTS**

1. Check drive belt tension by pushing on belts halfway between pulleys. If belts move more than about 3/4 inch (1.9 cm), they need adjustment. Notify unit maintenance.

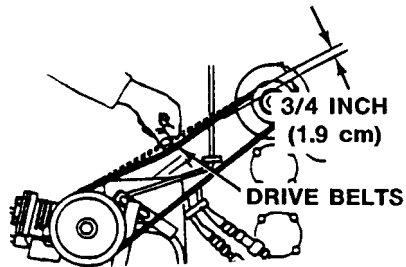
**END OF TASK**

REMOVE/INSTALL HULL BOTTOM ACCESS COVER AND DRAIN COVER

0076 00

THIS WORK PACKAGE COVERS:

Removal (page 0076 00-1).
 Installation (page 0076 00-4).

INITIAL SETUP:

Maintenance Level

Operator

Personnel Required

Soldier

Tools and Special Tools

Socket Wrench Handle (WP 0082 00, Item 27)
 Socket Wrench, 9/16 inch (WP 0082 00, Item 38)

Equipment Condition

Engine stopped (WP 0023 00), (WP 0024 00)
 Carrier blocked (WP 0038 00)

REMOVAL

WARNING



Moving carrier can cause injury or death. Block carrier so it won't move before removing or installing access cover.

WARNING



Touching your bare hands or tools to the starter terminals or electrical leads when accessing through the bottom access cover may cause death or serious injury. Do not touch any electrical leads or terminals on the starter because there is 24 volts with over 200 amps connected directly from the batteries.

NOTE

Hull bottom access covers for M548A1 and M548A3 are different. Both access covers are shown. Do Step 1 for M548A1 hull bottom access covers, then go to Step 3. Do Step 2 for M548A3 hull bottom access cover, then go to Step 3.

Drain covers for M548A1 and M548A3 are the same and are removed and installed the same way.

1. Remove eight screws and washers that secure access cover and gasket to hull bottom. Remove access cover and gasket.

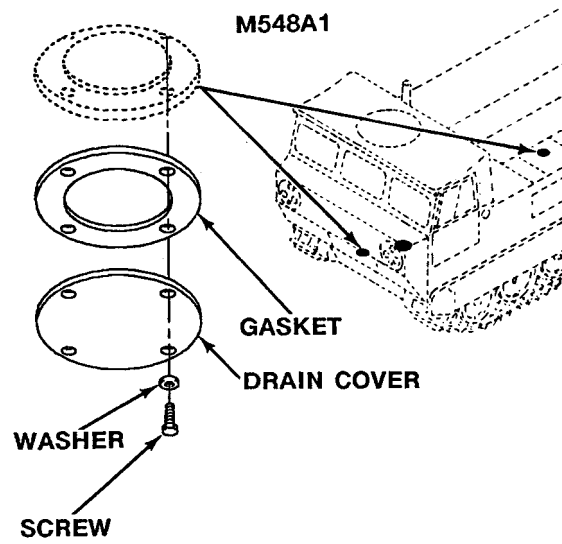

2. Remove 14 screws and washers that secure access cover and gasket to hull bottom. Remove access cover and gasket.

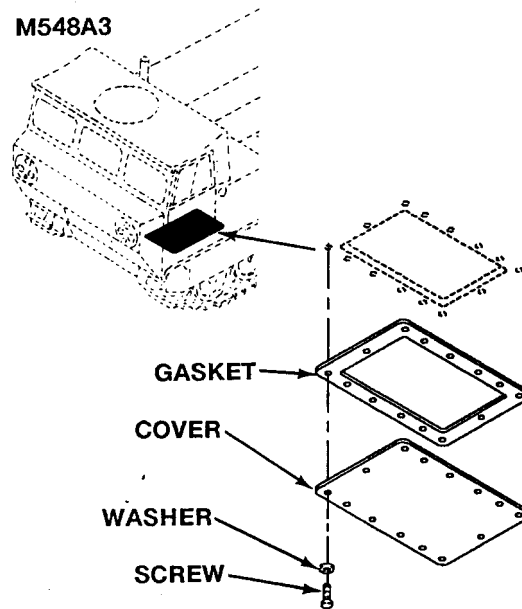

3. Remove four screws and washers that secure drain cover and gasket to hull bottom. Remove drain cover and gasket.

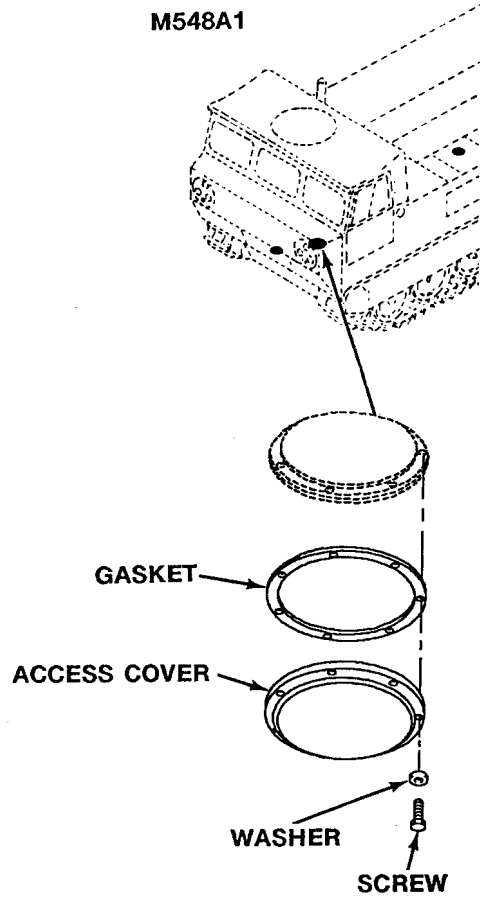

INSTALLATION

NOTE

Hull bottom access covers for M548A1 and M548A3 are different. Both access covers are shown.

Do Step 1 for drain covers. Do Step 2 for M548A1 hull bottom access cover. Do Step 3 for M548A3 hull bottom access cover.

1. Place gasket on drain cover. Install drain cover and gasket on hull bottom with four washers and screws.

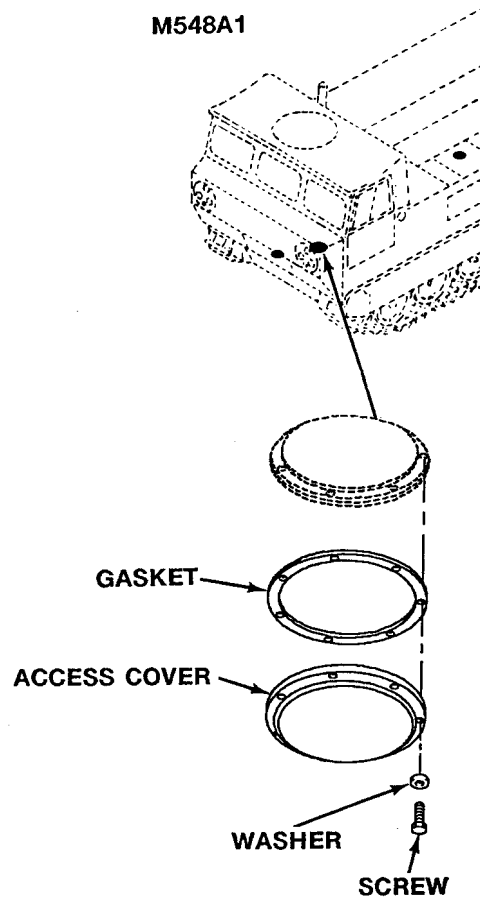

- Place gasket on access cover. Install access cover and gasket on hull bottom with eight washers and screws.

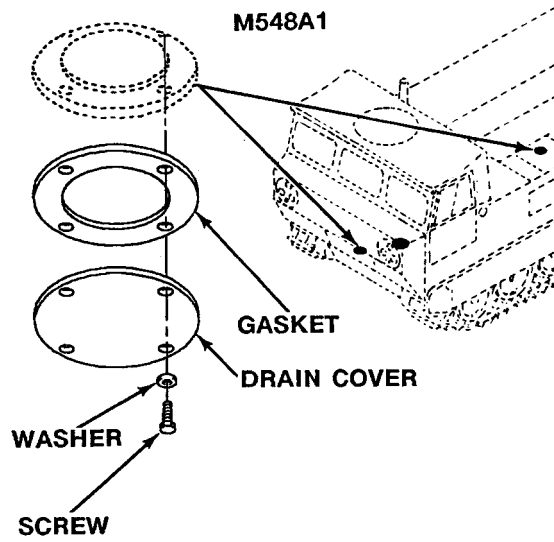

- Place gasket on access cover. Install access cover and gasket on hull bottom with 14 screws and washers.

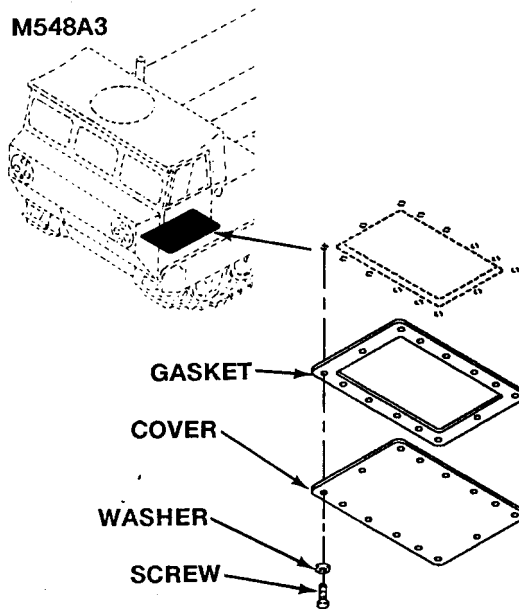

END OF TASK

RAISE/LOWER CAB CENTER FLOOR PLATES

0077 00

THIS WORK PACKAGE COVERS:

Raise (page 0077 00-1).
 Lower (page 0077 00-3).

INITIAL SETUP:

Maintenance Level

Operator

Equipment Condition

Engine stopped (WP 0023 00), (WP 0024 00)
 Carrier blocked (WP 0038 00)

Personnel Required

Soldier

REMOVAL

RAISE

NOTE

Raise Procedure Step 1 and Step 2, and Lower Procedure Step 2 and Step 3 are for M548A1 cab center floor plates. Both floor plates are raised and lowered in the same manner.

1. Loosen two tee bolts securing latch to latch retainer.
2. Turn two latches sideways from latch retainers. Raise cab floor plate.

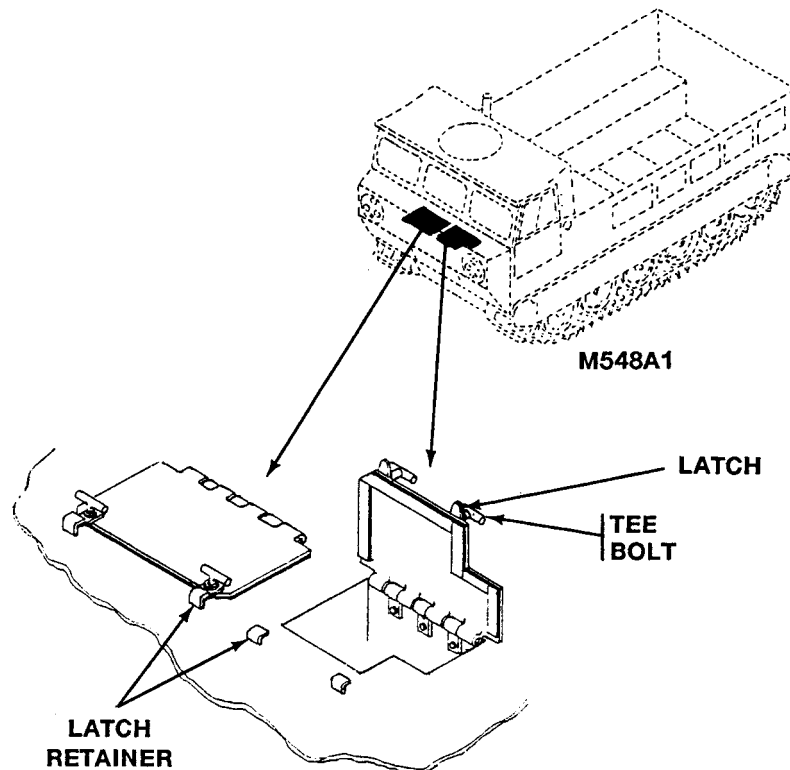

NOTE

Raise Procedure Step 3 and Step 4, and Lower Procedure Step 1 are for M548A3 cab center floor plates. Both floor plates are removed and installed in the same manner.

3. Remove three screws and washers securing rear of floor plate to hull.
4. Remove two screws, washers, and retainers securing front of floor plate. Remove floor plate.

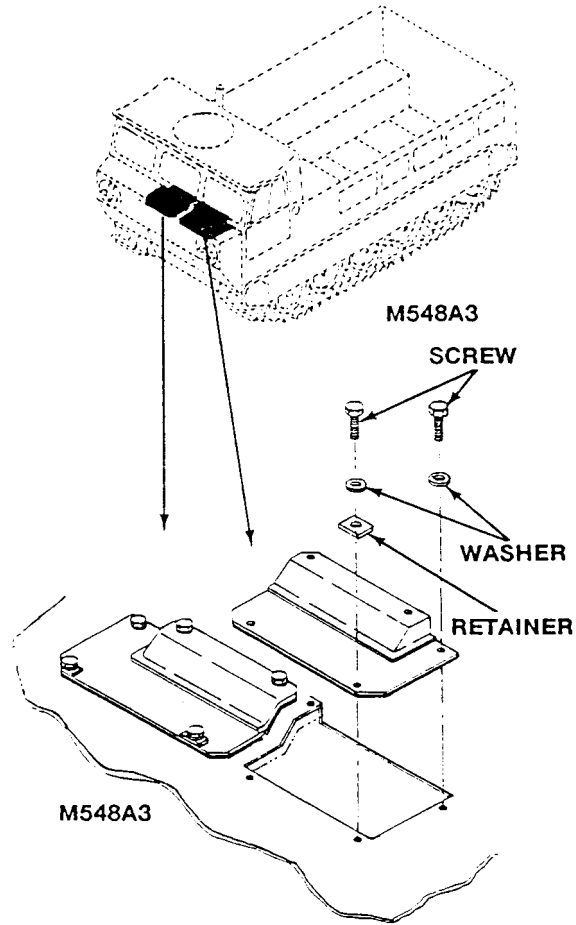

INSTALLATION

LOWER

1. Position cab floor plate and secure with five screws, washers and two retainers.

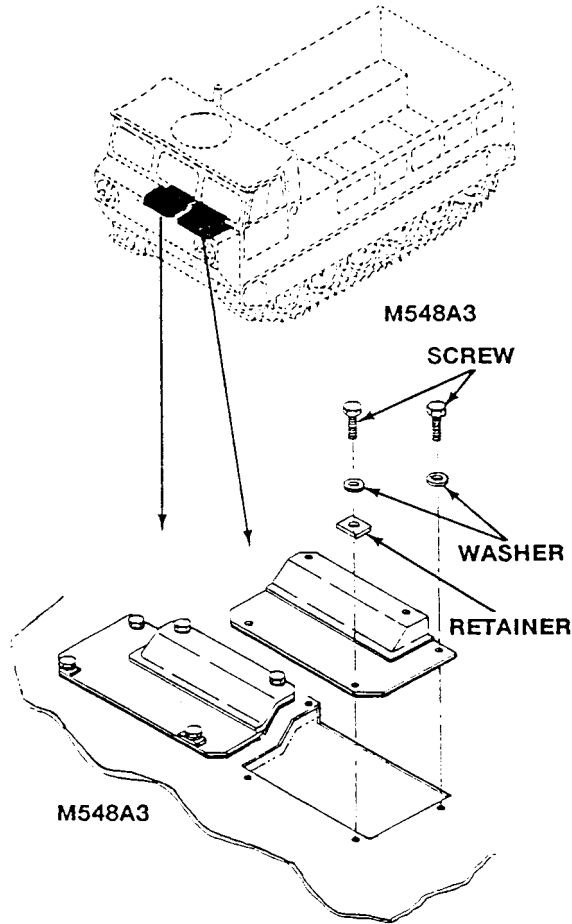

2. Lower cab center floor plate. Turn two latches under latch retainers.
3. Tighten two tee bolts.

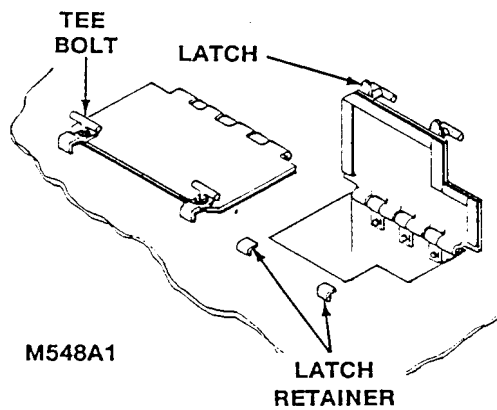

END OF TASK

REMOVE/INSTALL BULKHEAD PROTECTOR

0078 00

THIS WORK PACKAGE COVERS:

Removal (page 0078 00-1).
 Installation (page 0078 00-1).

INITIAL SETUP:

Maintenance Level

Operator

Personnel Required

Soldier

Tools and Special Tools

Socket Wrench Handle (WP 0082 00, Item 27)
 Socket Wrench, 9/16 inch (WP 0082 00, Item 38)

Equipment Condition

Engine stopped (WP 0023 00), (WP 0024 00)
 Carrier blocked (WP 0038 00)

REMOVAL

1. Remove three screws, washers, and plywood bulkhead protector from cargo compartment front bulkhead. Use socket and socket handle.

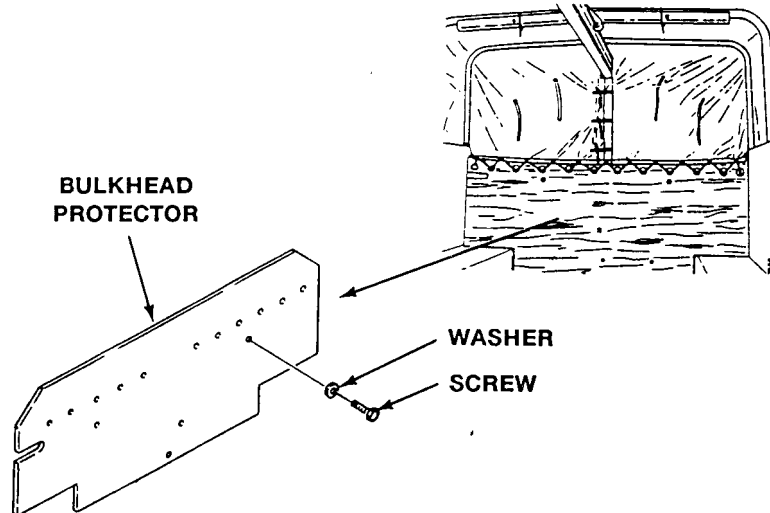

INSTALLATION

1. Install plywood bulkhead protector on cargo compartment front bulkhead. Secure with three screws and washers. Use socket and socket handle.

END OF TASK

CHAPTER 5

OPERATOR MAINTENANCE INSTRUCTIONS
FOR MAINTENANCE OF AUXILIARY EQUIPMENT

WORK PACKAGE INDEX

Title

Sequence No.

CLASSIFICATION AND IDENTIFICATION.....0079 00

CLASSIFICATION AND IDENTIFICATION

0079 00**SCOPE**

See TM 9-1300-200 for classification and identification of ammunition that could be used with the M548A1 and M548A3 cargo carriers.

MACHINE GUN AMMUNITION

The machine gun mounting kits provide stowage for two boxes of ammunition on the front mount supports, plus one box of ammunition carried as ready rounds. If the cal. 50 machine gun M2 is mounted on the carrier, 300 rounds of cal. 50 ammunition are authorized. If the 7.62 mm machine gun M60 is mounted on the carrier, 660 rounds of 7.62 mm ammunition are authorized.

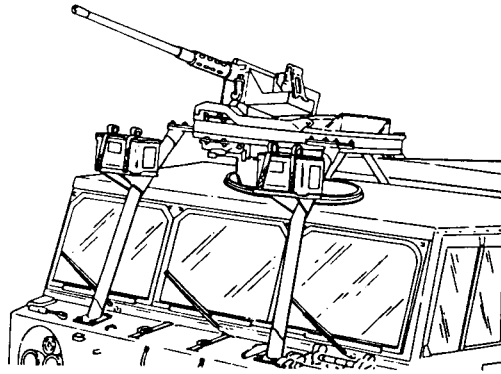
**MACHINE GUN AMMUNITION - TYPICAL****RIFLE AMMUNITION**

The carrier provides stowage inside the cab for two cases of rifle ammunition. The ammunition cases are stowed on the cab floor plate just below the right cab door. Either 5.56 mm ammunition or 7.62 mm ammunition could be issued, depending on the type of rifle you're carrying. Whichever type of ammunition is used, 360 rounds are authorized for a two-man carrier crew. If you are carrying a material handling crew or other passengers, they could have additional ammunition for their rifles. No special stowage is provided for additional ammunition.

CHAPTER 6

OPERATOR SUPPORTING INFORMATION

WORK PACKAGE INDEX

<u>Title</u>	<u>Sequence No.</u>
REFERENCES.....	.0080 00
COMPONENTS OF END ITEM AND BASIC ISSUE ITEMS.....	.0081 00
ADDITIONAL AUTHORIZATION LIST (AAL).....	.0082 00
EXPENDABLE/DURABLE SUPPLIES AND MATERIALS LIST.....	.0083 00
STOWAGE GUIDE.....	.0084 00

REFERENCES

0080 00

SCOPE

This work package lists all forms, field manuals, technical manuals, and miscellaneous publications referenced in or related to information contained in this manual.

FORMS

Equipment Inspection and Maintenance Worksheet.....DA Form 2404
 Maintenance Request.....DA Form 2407
 Recommended Changes to DA Publications.....DA Form 2028
 Uncorrected Fault Record.....DA Form 2408-14
 Vehicle Accident Report.....SF 91

FIELD MANUALS

Basic Cold Weather Manual.....FM 31-70
 First AidFM 4-25.11
 Mountain Operations.....FM 3-97.6
 NBC Decontamination.....FM 3-5
 Northern Operations.....FM 31-71
 Operation and Maintenance of Ordnance Materiel in Cold Weather (0° to -65°F).....FM 9-207
 Vehicle Recovery Operations.....FM 9-43-2

TECHNICAL MANUALS

Destruction of Conventional Ammunition and Improved Conventional Munitions (ICM) to Prevent Enemy Use.....TM 43-0002-33
 General Ammunition.....TM 9-1300-200
 Operator’s and Organizational Maintenance Manual Including Repair Parts and Special Tool List for Decontaminating Apparatus: Portable, 14 Liter, M13, NSN 4230-01-133-4124.....TM 3-4230-214-12&P
 Operator’s Manual: Machine Gun, Cal .50; Browning, M2, Heavy Barrel, Flexible, w/e (1005-322-9715); Mount, Tripod, Machine Gun, Cal .50, M3, w/e (1005-322-9716); Mount, Machine Gun, Anti-aircraft, Cal .50, M63, w/e (1005-673-3246).....TM 9-1005-213-10
 Operator’s Manual for Chemical-Biological Mask: Combat Vehicle, M42TM 3-4240-300-10-2
 Operator’s Manual: M60 Machine Gun.....TM 9-1005-224-10
 Operator’s Manual: Radio Sets; AN/VRC-12, AN/VRC-43, AN/VRC-44, AN/VRC-45, AN/VRC-46, AN/VRC-47, AN/VRC-48, AN/VRC-49 (used with intercom systems).....TM 11-5820-401-10-2
 Operator’s, Organizational, DS and GS Maintenance Manual: Storage Batteries, Lead-Acid Type.....TM 9-6140-200-14

REFERENCES — Continued

0080 00

Operator's, Unit, and Direct Support Maintenance Manual with Repair Parts and Special Tools List (RPSTL) for Machine Gun Mounts and Combinations for Tactical/Armored Vehicles and Ground Mounting M122 Machine Gun Tripod Mount; M122A1 Machine Gun Mount, M3 Tripod Mount, M66 Machine Gun Mount Ring, M240E1 Flexible Machine Gun Mount, M142 Machine Gun Mount, .50 Cal Machine Gun Mount, M548 Machine Gun Mount, MK93 Mod 0 Machine Gun Mount (USMC Only), MK 93 Mod 1 Machine Gun Mount, M6 Machine Gun Pedestal Mount, M197 Machine Gun Mount.....TM 9-1005-245-13&P

Operator's and Organizational Maintenance Manual: Radio Sets AN/VRC-53, AN/VRC-64, and AN/GRC-160.....TM 11-5820-498-12

Procedures for Destruction of Electronics Materiel to Prevent Enemy Use.....TM 750-244-2

Procedures for Destruction of Tank-Automotive Equipment to Prevent Enemy Use (US Army Tank-Automotive Command).....TM 750-244-6

Procedures for Destruction of Equipment in Federal Supply Classifications 1000, 1005, 1010, 1015, 1020, 1025, 1030, 1055, 1090, and 1095 to Prevent Enemy Use.....TM 750-244-7

Unit, Direct Support and General Support Maintenance Manual Standards for Inspection and Classification of Tracks, Track Components and Solid-Rubber Tires.....TM 9-2530-200-24

Use and Care of Hand Tools and Measuring Tools.....TM 9-243

OTHER PUBLICATIONS

Army Oil Analysis Program (AOAP).....TB 43-0211

Occupational and Environmental Health Preventive, Treatment, and Control of Heat Injury.....TB Med 507

Prevention of Motor Vehicle Accidents.....AR 385-55

Safety Inspection and Testing of Lifting Devices.....TB 43-0142

The Army Maintenance Management System (TAMMS).....DA PAM 738-750

Tracked Combat Vehicle Driver Training.....TC 21-306

Use of Antifreeze Solutions, Antifreeze Extender, Cleaning Compounds, and Test Kits in Engine Cooling System.....TB 750-651

COMPONENTS OF END ITEM AND BASIC ISSUE ITEMS**0081 00****INTRODUCTION****SCOPE**

This work package lists components of end item and basic issue items for the M548A1 and M548A3 carriers. This work package is to help you inventory items required for safe and efficient operation.

GENERAL

This Components of End Item List is divided into the following sections:

- (1) Components of End Item. This listing is for informational purposes only, and is not authority to requisition replacements. These items are part of the end item, but are removed and separately packaged for transportation or shipment. As part of the end item, these items must be with the end item whenever it is issued or transferred between property accounts. Illustrations will help you identify the items.
- (2) Basic Issue Items. These are the minimum essential items required to place the M548A1 and M548A3 carriers in operation and to perform emergency repairs. Although shipped separately packed, they must accompany the carrier during operation and whenever it is transferred between accountable officers. The illustrations will assist you with hard-to-identify items. This manual is your authority to requisition replacement BII, based on TOE/MTOE authorization of the end item.

EXPLANATION OF COLUMNS

Column (1) - Illustration Number (Illus. Number). Gives you the number of the item illustrated.

Column (2) - National Stock Number (NSN). Identifies the stock number of the item to be used for requisitioning purposes.

Column (3) - Description, CAGEC, and Part Number. Identifies the federal item name (in all capital letters) followed by a minimum description when needed. The stowage location of COEI and BII is also included in this column. The last line below the description is the CAGEC (Commercial and Government Entity Code) (in parentheses) and the part number.

Column (4) - Usable On Code. When applicable, gives you a code if the item you need is not the same for different models of equipment. These codes are identified below:

<u>CODE</u>	<u>USED ON</u>
V96	M548A1
AP4	M548A3

Column (5) - Unit of Measure (U/M). Indicates the physical measurement or count of the item as issued per the national stock number shown in column (2).

Column (6) - Quantity Required (Qty Rqr). Indicates the quantity required.

COMPONENTS OF END ITEM (COEI) LIST

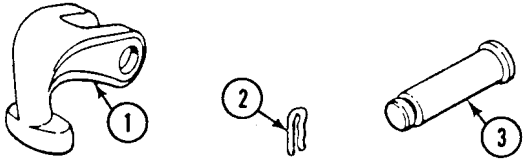

COMPONENTS OF END ITEM AND BASIC ISSUE ITEMS — Continued

0081 00

Table 1. Components of End Item List

(1) ILLUS NUMBER	(2) NATIONAL STOCK NUMBER	(3) DESCRIPTION, CAGEC, AND PART NUMBER	(4) USABLE ON CODE	(5) U/M	(6) QTY RQR
1	2540-00-679-8035	HOOK, tow (on front towing eyes) (19207) 10861607		EA	2
2	5315-00-598-5808	PIN, lock, tow hook (on tow hook) (19207) 7752865		EA	2
3	5315-00-862-2683	PIN, straight, tow hook (on tow hook) (19207) 10890323		EA	2

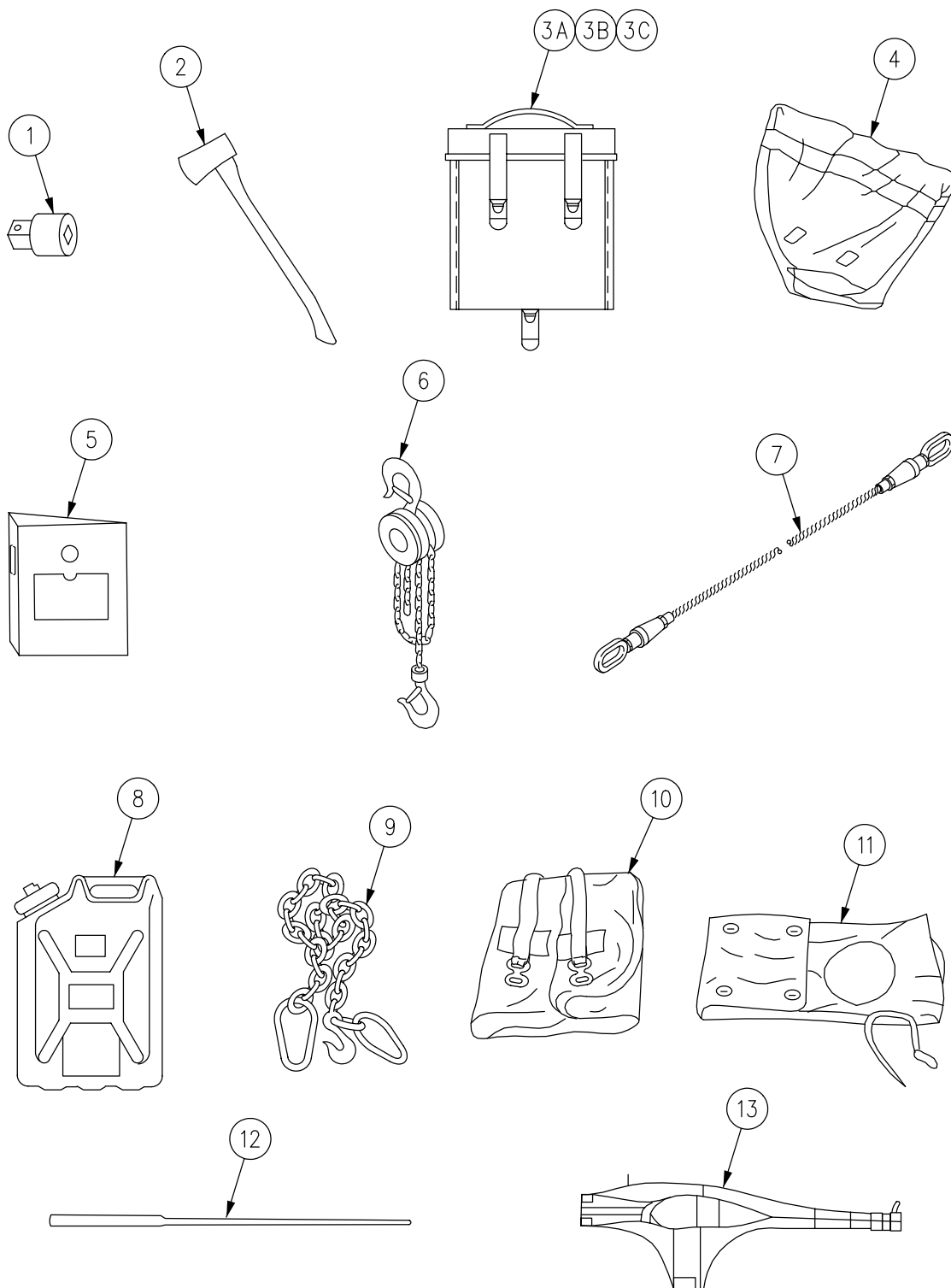

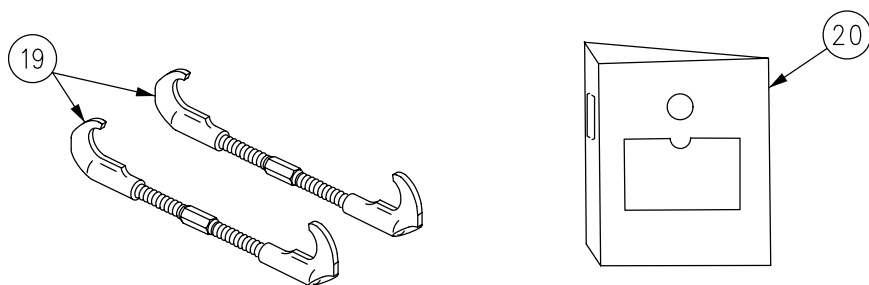
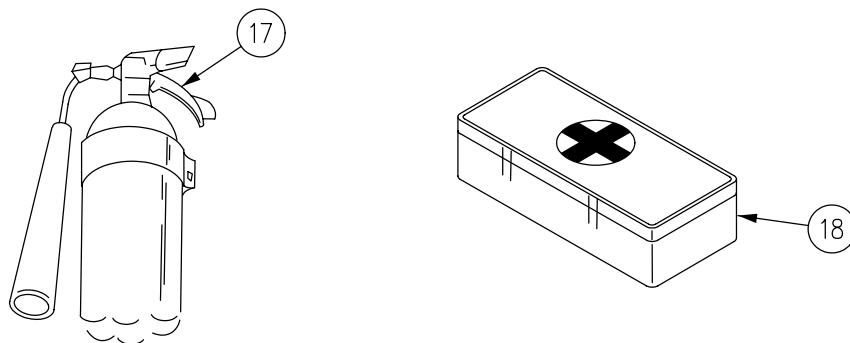
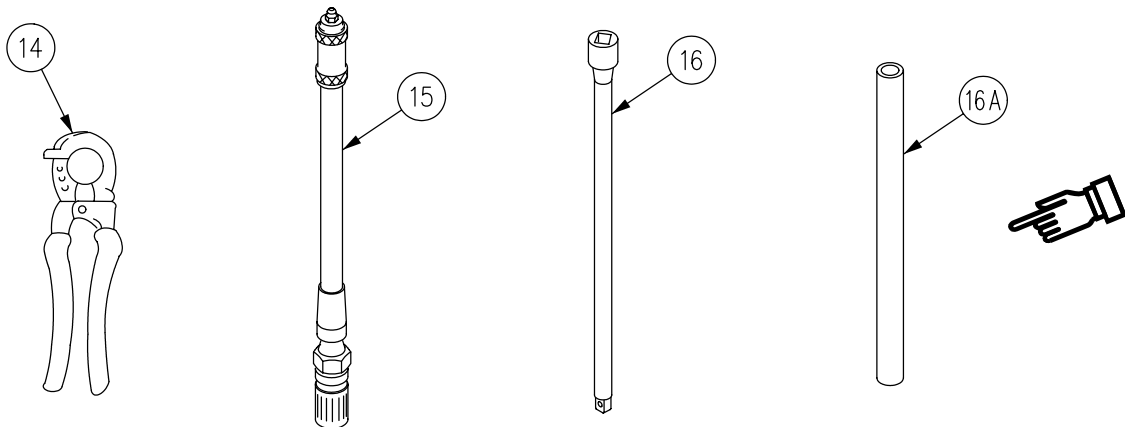

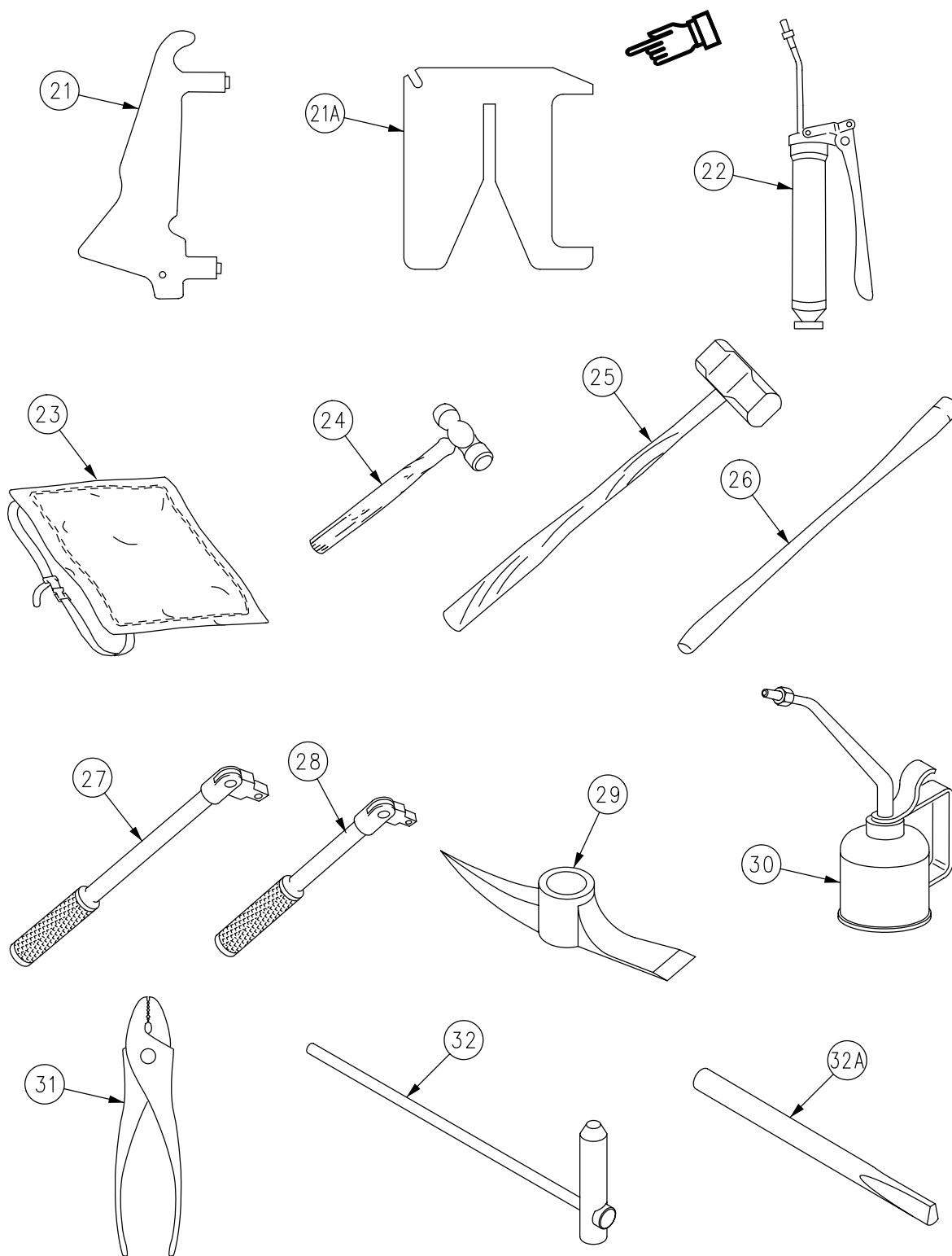

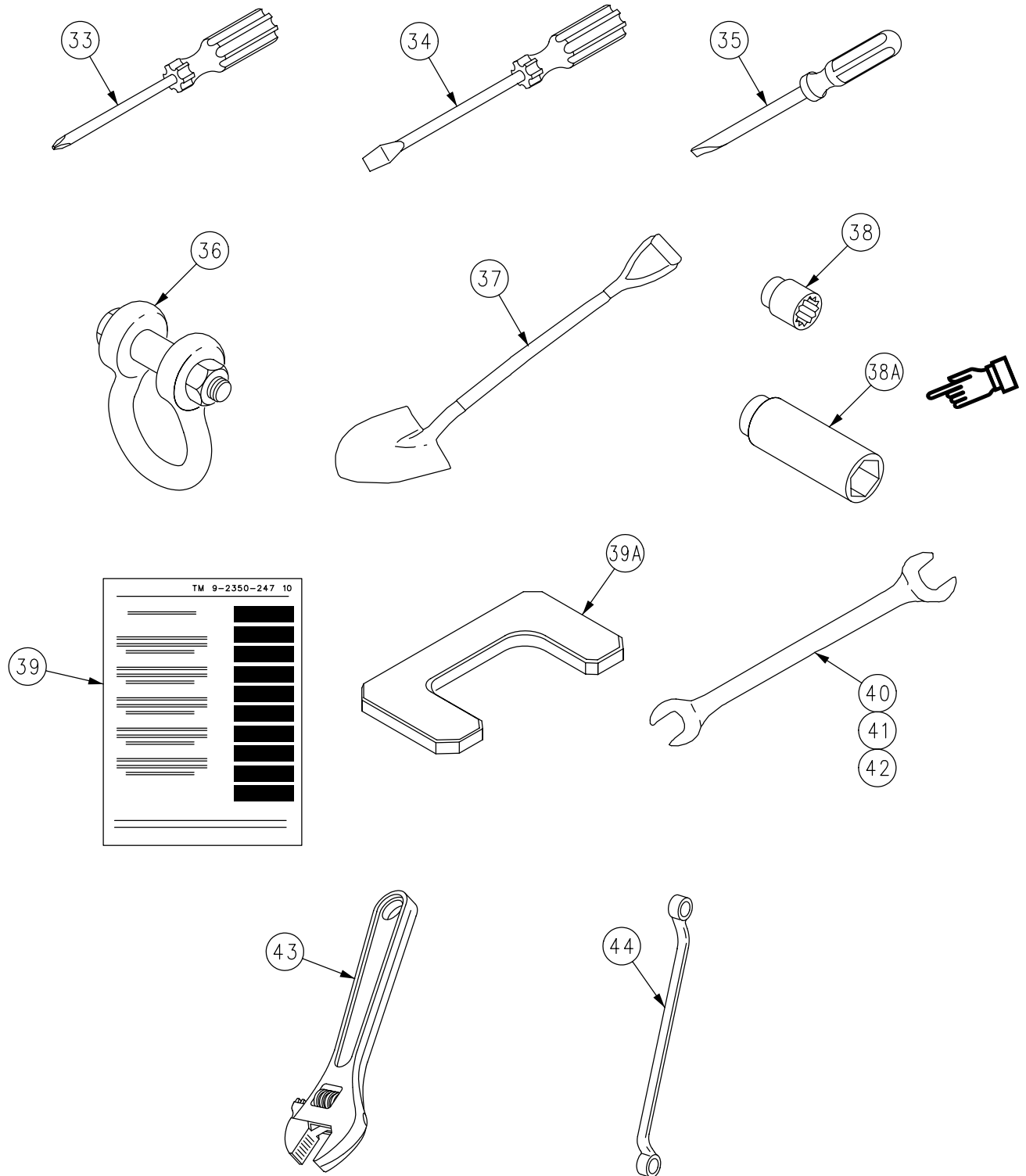

COMPONENTS OF END ITEM AND BASIC ISSUE ITEMS — Continued

0081 00

Table 2. Basic Issues Item (BII) List

(1) ILLUS NUMBER	(2) NATIONAL STOCK NUMBER	(3) DESCRIPTION, CAGEC, AND PART NUMBER	(4) USABLE ON CODE	(5) U/M	(6) QTY RQR
1	5120-00-144-5207	ADAPTER, socket wrench, 3/4 in. male X 1/2 in. female (in tool bag) (19207) 11655788-3		EA	1
2	5110-00-293-2336	AXE, single bit, 4 lb (under side of personnel seat) (19207) 6150925		EA	1
3A	2540-00-670-2459	BAG, pamphlet (inside right door) (19207) 7961712 (green)		EA	1
3B	2540-00-670-2459	BAG, pamphlet (inside right door) (19207) 7961712 (tan)		EA	1
3C	2540-00-670-2459	BAG, pamphlet (inside right door) (19207) 7961712 (white)		EA	1
4	5140-00-473-6256	BAG, tool (in driver's compartment) (19207) 11655979		EA	1
5	7510-00-889-3494	BINDER, loose leaf (in pamphlet bag) (19207) 11677003		EA	1
6	3940-00-105-9933	BLOCK, rigging, recov. (on front of hull) (19207) 11631726	V96	EA	1
7	4010-00-767-3149	CABLE, tow (on tailgate) (19207) 10861718		EA	1
8	7240-00-089-3827 OR	CAN, water, military (in driver's compartment, right side) (81349) MIL-C-43613 Type 1 (tan)		EA	1
8A	7240-01-365-5317	CAN, water, military (81349) MIL-C-43613 Type 2 (green)		EA	1
9	4010-00-473-6166	CHAIN, utility (under water can) (M548A1 only) (19207) 7077063		EA	1
10	2540-00-411-8322	COVER, air intake (in cab) (19207) 11633840		EA	1
11	2540-01-136-8700	COVER, radiator (in cab) (19207) 12269477		EA	1
12	5120-00-240-6040	CROWBAR, pinch (on front hull) (19207) 11677049		EA	1
13	1005-00-487-4100	COVER, .50 caliber machine gun (on .50 caliber machine gun) (19204) 11631791		EA	1
14	5110-00-595-8229	CUTTER, wire, M1938 (in tool bag) (19207) 11655981		EA	1
15	4930-00-288-1511	EXTENSION, adapter, grease gun (in tool bag) (19207) 6300333		EA	1
16	5120-00-227-8074	EXTENSION, bar, 1/2 in. x 10 in. (in tool bag) (19207) 11655788-1		EA	1
16A	5120-00-473-6320	EXTENSION, wrench handle, (secured under tool bag) (51719) 36A		EA	1

COMPONENTS OF END ITEM AND BASIC ISSUE ITEMS — Continued

0081 00

(1) ILLUS NUMBER	(2) NATIONAL STOCK NUMBER	(3) DESCRIPTION, CAGEC, AND PART NUMBER	(4) USABLE ON CODE	(5) U/M	(6) QTY RQR
17	4210-00-270-4512	EXTINGUISHER, fire, 5 lb (in driver's compartment) (19207) 7714780		EA	1
18	6545-00-922-1200	FIRST AID KIT (in driver's compartment) (19207) 11677011		EA	1
19	5120-01-041-4624	FIXTURE, track (on front of hull) (19207) 12253183		EA	2
20	7510-01-065-0166	FOLDER, equipment record (in pamphlet bag) (72094) 43986-1		EA	1
21	5220-01-041-9920	GAUGE, profile, T130 (in tool bag) (19207) 12253280		EA	1
21A	5220-01-496-3692	GAUGE, track tension and sprocket wear, T150 (in tool bag) (19207) 12474849		EA	1
22	4930-00-253-2478	GREASE GUN, hand (in tool bag) (36251) 1142		EA	1
23	2540-00-072-5957	GRILLE, cover (in cab or on intake and exhaust grille) (19207) 11612858		EA	2
	OR	GRILLE, cover (in cab or on intake and exhaust grille) (19207) 11612858-T (tan)		EA	2
24	5120-00-061-8546	HAMMER, hand, ball peen, 2 lb (in tool bag) (19207) 11677028-3		EA	1
25	5120-00-265-7462	HAMMER, hand, sledge, 6 lb (on front hull) (19172) 41796		EA	1
26	5120-00-288-6574	HANDLE, mattock pick (under personnel seat) (19207) 11677021		EA	1
27	5120-00-236-7590	HANDLE, socket wrench, 1/2 in. drive (in tool bag) (19207) 11655786-1		EA	1
28	5120-00-709-4072	HANDLE, socket wrench, 3/4 in. drive (under tool bag) (55179) L52BH		EA	1
29	5120-00-243-2395	MATTOCK, pick type (on front of hull) (19207) 11677022		EA	1
30	4930-00-262-8868	OILER, hand pump type (in cab compartment, left side) (58536) A50477-1-4-8-6		EA	1
31	5120-00-223-7397	PLIERS, lineman, w/cutter (in tool bag) (56161) 10510983		EA	1
32	5120-01-006-8847	PUNCH, drive pin (in tool bag) (19207) 11678718		EA	1
32A	5120-01-496-3689	REMOVER, end connector (in tool bag) (19207) 12474798		EA	1

COMPONENTS OF END ITEM AND BASIC ISSUE ITEMS — Continued

0081 00

(1) ILLUS NUMBER	(2) NATIONAL STOCK NUMBER	(3) DESCRIPTION, CAGEC, AND PART NUMBER	(4) USABLE ON CODE	(5) U/M	(6) QTY RQR
33	5120-00-234-8913	SCREWDRIVER, cross tip, No. 2 (in tool bag) (19207) 11655777-12		EA	1
34	5120-00-278-1283	SCREWDRIVER, flat tip (in tool bag) (19207) 11655777-11		EA	1
35	5120-00-236-2140	SCREWDRIVER, flat tip, 2 in. (in tool bag) (81348) GGG-S-121		EA	1
36	4030-01-369-7612	SHACKLE (in tool bag) (not required if vehicle has the new tiedown plates on the bottom rear hull and two new style front towing eyes) (19207) 12381884		EA	2
37	5120-00-293-3336	SHOVEL, hand (on front of hull) (19207) 11655784		EA	1
38	5120-00-189-7932	SOCKET, wrench, 1/2 in. x 9/16 in. (in tool bag) (19207) 11677025-1		EA	1
38	5120-00-189-7946	SOCKET, wrench, 1/2 in. x 5/8 in. (in tool bag) (19207) 11677025-2		EA	1
38	5120-00-235-5870	SOCKET, wrench, 1/2 in. x 11/16 in. (in tool bag) (19207) 11677025-3		EA	1
38	5120-00-189-7985	SOCKET, wrench, 1/2 in. x 3/4 in. (in tool bag) (19207) 11677025-4		EA	1
38	5120-00-189-7934	SOCKET, wrench, 1/2 in. x 7/8 in. (in tool bag) (19207) 11677025-5		EA	1
38	5120-00-189-7935	SOCKET, wrench, 1/2 in. x 15/16 in. (in tool bag) (19207) 11677025-6		EA	1
38A	5130-00-227-6681	SOCKET, wrench, 1 1/8 in. (in tool bag) (55719) IM362		EA	1
39		TECHNICAL MANUAL (in binder) □ TM 9-2350-247-10		EA	1
39A	5220-01-504-2610	TOOL, track pin alignment (in tool bag) (19207) 12474881		EA	1
40	5120-00-277-2342	WRENCH, open end, fixed, 3/8 in. x 7/16 in. (in tool bag) (19207) 11655789-1		EA	1
41	5120-00-187-7126	WRENCH, open end, fixed, 9/16 in. x 5/8 in. (in tool bag) (19207) 11655789-2		EA	1
42	5120-00-277-8300	WRENCH, open end, fixed, 11/16 in. x 13/16 in. (in tool bag) (19207) 11655789-3		EA	1
43	5120-00-264-3796	WRENCH, open end, adjustable, 1-5/16 in. x 12 in. (in tool bag) (19207) 11655778-5		EA	1
44	5120-00-224-3141	WRENCH, box end, fixed, 5/8 in. x 11/16 in. (in tool bag) (19207) 11655785-2		EA	1

ADDITIONAL AUTHORIZATION LIST (AAL)

0082 00

INTRODUCTION

SCOPE

This work package lists additional items you are authorized to help support the carrier.

GENERAL

This WP lists additional items you are authorized for support of the carrier that do not have to be turned in with it. These items are all authorized to you by CTA, MTOE, TDA, or JTA. lists expendable supplies and materials you will need to operate and maintain the carrier. These items are authorized to you by CTA 50-970, Expendable Items (except medical, class V, repair parts, and heraldic items).

EXPLANATION OF COLUMNS

Column (1) — National Stock Number (NSN). Indicates the national stock number assigned to the item which will be used for requisitioning purposes.

Column (2) — Description, CAGEC, and Part Number. Indicates the Federal item name and, if required, a minimum description to identify the item. Following the part name is the Commercial and Government Entities Code (CAGEC) (in parentheses) and the part number.

Column (3) — Usable On Code. When applicable, gives you a code if the item you need is not the same for different models of equipment. These codes are identified below:

<u>CODE</u>	<u>USED ON</u>
V96	M548A1
AP4	M548A3

Column (4) — Unit of Measure (U/M). Indicates the measure used in performing the actual operational/maintenance function. This measure is expressed by a two-character alphabetical abbreviation (e.g., ea, in, pr).

Column (5) — Quantity Recommended (Qty RECM). Indicates the quantity of the item authorized to be used with/on the equipment.

Table 1. Additional Authorization List

(1) NATIONAL STOCK NUMBER	(2) DESCRIPTION, CAGEC, AND PART NUMBER	(3) USABLE ON CODE	(4) U/M	(5) QTY RECM
4930-00-204-2550	ADAPTER, GREASE GUN (81349) MIL-L-4387		EA	1
5120-00-926-5175	BRUSH, CLEANING, BATTERY (36540) BT1		EA	1
5140-00-261-4994	CARRIER, WIRE CUTTER M1938 (19207) 11655787		EA	1
4230-01-133-4124	DECONTAMINATING APPARATUS, PORTABLE, 14 L, M13 (FRONT RIGHT EXTERIOR HULL) (81361) E5-51-527		EA	1
4240-00-052-3776	GOGGLES, INDUSTRIAL (58536) A-A1110		EA	1
5120-01-399-9254	HAMMER, HAND, 4 LB (1CV05) 1435G		EA	1
2590-01-107-9596	LIGHT, AMBER ROTATING WARNING (19207) 12296622		EA	1

ADDITIONAL AUTHORIZATION LIST (AAL) — Continued

0082 00

(1) NATIONAL STOCK NUMBER	(2) DESCRIPTION, CAGEC, AND PART NUMBER	(3) USABLE ON CODE	(4) U/M	(5) QTY RECM
3950-00-725-5261	MATERIAL HANDLING KIT, HOIST, CARGO COMPT (19207) 11633807		EA	1
8415-01-092-0039	MITTEN, CLOTH, HEAT PROTECTIVE (81349) MIL-M-11199F		PR	1
5315-00-839-2325	PIN, COTTER: 1/16 X 1/2 IN. (80205) MS24665-132		EA	1
5315-00-999-9781	PIN, SHEAR, STRAIGHT (19207) 10949934		EA	1
5120-00-273-0001	PUNCH, PIN DRIVE, SIZE 9 (19207) 11677010-5		EA	1
1005-00-783-5494	RING MOUNT KIT, M66, CAL .50 (ABOVE CAB) (19207) 11631740-2		EA	1
5120-00-189-7914	SOCKET, 1/2 IN. DRIVE (12 PT) 1-1/8 IN. OPENING (19207) 11677025-10		EA	1
7240-00-255-8113	SWING SPOUT, OIL CAN (1JZ80) 6110-007		EA	1
5120-00-224-3154	WRENCH, BOX: 1/2 X 9/16 IN. (19207) 11655785-1		EA	1
5120-00-240-5609	WRENCH, OPEN END, FIXED: 3/4 X 7/8 IN. (19207) 11655789-4		EA	1
5120-00-277-7025	WRENCH, OPEN END, FIXED: 15/16 X 1 IN. (19207) 11655789-5		EA	1

EXPENDABLE/DURABLE SUPPLIES AND MATERIALS LIST

0083 00

INTRODUCTION

SCOPE

This work package lists expendable/durable supplies and materials you need to operate and maintain the carrier. These items are authorized to you by CTA 50-970, Expendable Items (Except Medical, Class V, Repair Parts, and Heraldic Items).

EXPLANATION OF COLUMNS

Column (1) - Item Number. This number is assigned to the entry in the listing and is referenced in the narrative instructions to identify the material (e.g., Use eight batteries (WP 0083 00, Item NSN-6135-00-120-1020).

Column (2) - Level. This column identifies the lowest level of maintenance that requires the listed item (e.g., C - Operator/Crew).

Column (3) - National Stock Number. This is the national stock number assigned to the item; use it to request or requisition the item.

Column (4) - Description. Indicates the Federal item name and, if required, a description to identify the item. The last line for each item indicates the Commercial and Government Entity Code (CAGEC) in parentheses followed by the part number.

Column (5) - Unit of Measure (U/M). Indicates the measure used in performing the actual maintenance function. This measure is expressed by a two-character alphabetical abbreviation (e.g., ea, in, pr). If the unit of measure differs from the unit of issue, requisition the lowest unit of issue that will satisfy your requirements.

Table 1. Expendable and Durable Items List

(1) ITEM NUMBER	(2) LEVEL	(3) NATIONAL STOCK NUMBER	(4) ITEM NAME, DESCRIPTION, CAGEC, PART NUMBER	(5) U/M
1	C	6810-00-205-6790	ALCOHOL, DENATURED (OE-760), 4 OZ (114 CC) BTL	EA
2	C	6850-00-181-7929	ANTIFREEZE, ETHYLENE GLYCOL, INHIBITED (MIL-A-46153) 1 GL (4 L) CN	GL
3	C	6135-00-120-1020	BATTERY, DRY, 1.5 VOLT (96906) (MS75059)	EA
4	C	8020-00-245-4509	BRUSH, PAINT, 1 IN. (2.5 CM) WIDE	EA
5	C	6720-00-240-7174	BRUSH, SCRUB	EA
6	C	7520-00-223-8000	BRUSH, STENCIL (H-B-621) TYPE F, 3/4 IN. DIA (19.0 MM)	EA
7	C	7920-00-282-9246	BRUSH, WIRE, SCRATCH, STEEL WIRE	EA
8	C	7920-00-044-9281	CLOTH, CLEANING, LINTLESS, 10 LB (5 KG) BX	EA
9	C	8030-00-251-3980	COMPOUND, ANTISEIZE (MIL-A-907) 1 LB (0.5 KG) TUBE	EA
10	C	8030-00-231-2345	COMPOUND, CORROSION PREVENTIVE, GRADE 1 (MIL-C-16173)	OZ
11	C	6230-00-264-8261	FLASHLIGHT, ELECTRIC, HAND, 2-CELL (MX 991U)	EA
12	C	8415-00-634-5032	GLOVES, SYNTHETIC RUBBER	EA
13	C	4240-00-816-3819	GOGGLES	EA
13.1	C	9150-00-985-7244	GREASE, AIRCRAFT AND INSTRUMENT (GIA) (1 LB CAN) (81349) MIL-PRF-23827C	LB

EXPENDABLE/DURABLE SUPPLIES AND MATERIALS LIST — Continued

0083 00

(1) ITEM NUMBER	(2) LEVEL	(3) NATIONAL STOCK NUMBER	(4) ITEM NAME, DESCRIPTION, CAGEC, PART NUMBER	(5) U/M
14	C	9150-01-197-7689	GREASE, GAA (MIL-PRF-10924G) 6.5 LB/CN	LB
14.1	C	9150-00-402-2372	LUBRICATING OIL, INTERNAL COMBUSTION ENGINE, ARCTIC (OEA) (81349) MIL-PRF-46167C	QT
15	C	9150-00-183-7307	OIL, OE/HDO (MIL-PRF-2104G) OE 15/40 1 GL	GL
16	C	7920-00-205-1711	RAG, WIPING, COTTON AND COTTON SYNTHETIC (81348) DDD-R-30, GRADE B, (58536) A-A-53	LB
17	C	7930-00-170-5466	SOAP, LIQUID (PS-560) 1 QT (1 L) BTL	EA
18	C	9505-00-331-3275	WIRE, LOCK (MS20995-C41) 0.04 IN DIA (1 MM)	RL
19	C	5975-00-627-1552	ROD, GROUND: 0.75 IN DIA STYLE	TBS
20	C	6850-01-277-0595	CLEANING COMPOUND, SOLVENT (59557) 134-HI-SOLV	CN

STOWAGE GUIDE

0084 00

SCOPE

This work package shows the locations for stowage of equipment and materiel on the M548A1 and M548A3 carriers.

GENERAL

The pictures below and on the following pages show the location of basic issue items, troop installed or authorized items, and straps used on the carrier. Number callouts refer to the strap key.

STOWAGE GUIDE — M548A1



Ammunition is sensitive to heat and could detonate or explode. Personnel could be killed or injured if ammunition gets into engine compartment. Do not operate carrier carrying cargo without rear engine access panels and plywood protector installed.

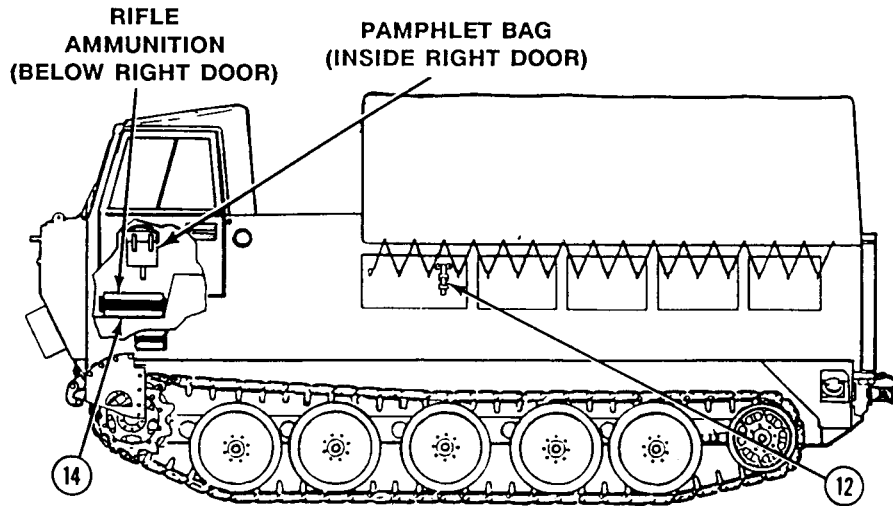

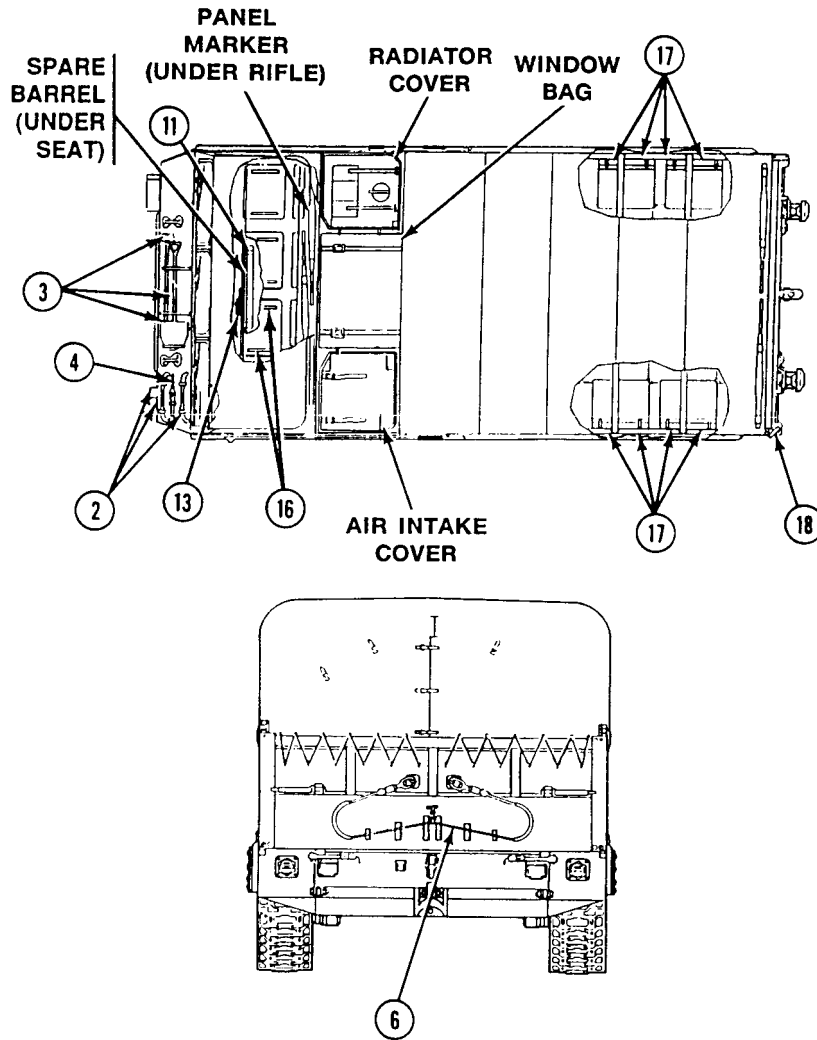

STOWAGE GUIDE—Continued

0084 00

STRAP KEY				
NO.	ITEM	QTY	LENGTH (INCHES)	WIDTH (INCHES)
1	Crowbar and mattock handle	2	20	1
2	Track fixtures	2	28	1
3	Axe, shovel, and sledge	2	36	1
4	Mattock head	1	18	1
*5	Machine gun ammo boxes	4	48	1
6	Tow cable	1	24	1
7	Fire extinguisher	1	24	1
8	First aid kit	1	24	1
9	Water can	1	60	1-1/2
10	Water can	1	54	1-1/2
11	Tool kit	2	45	1
12	Cargo door hold-open	1	18	1
13	Center seat support	1	26	1
14	Rifle ammo boxes	3	45	1
*15	Hoist chain	1	36	1
16	Seat cushions, cab	6	28	1
*17	Seat cushions, cargo area	8	33	1
*18	Air brake hose retaining	1	24	1
* Used with special purpose kits				

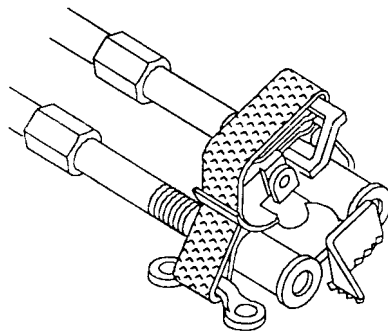
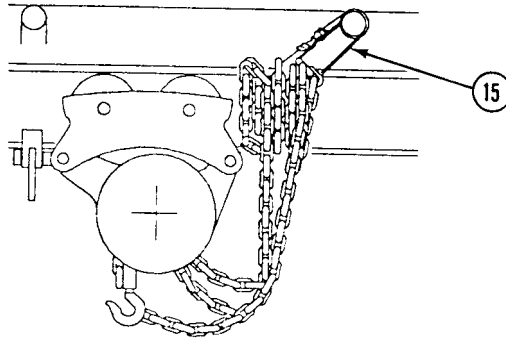

PROPER METHOD OF STRAPPING,
MAKE CERTAIN BOTH LOOPS PASS
OVER TOP OF SECURED ITEM.

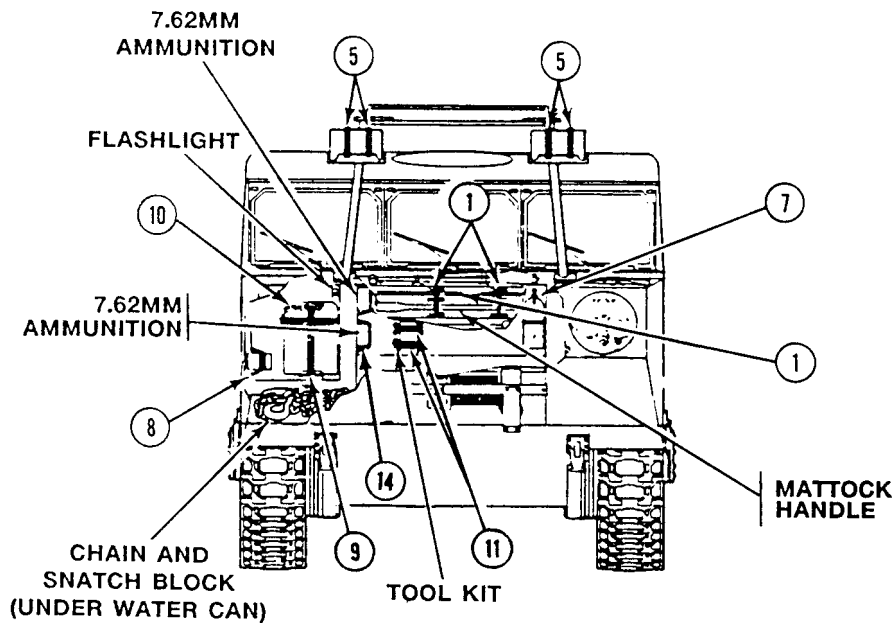

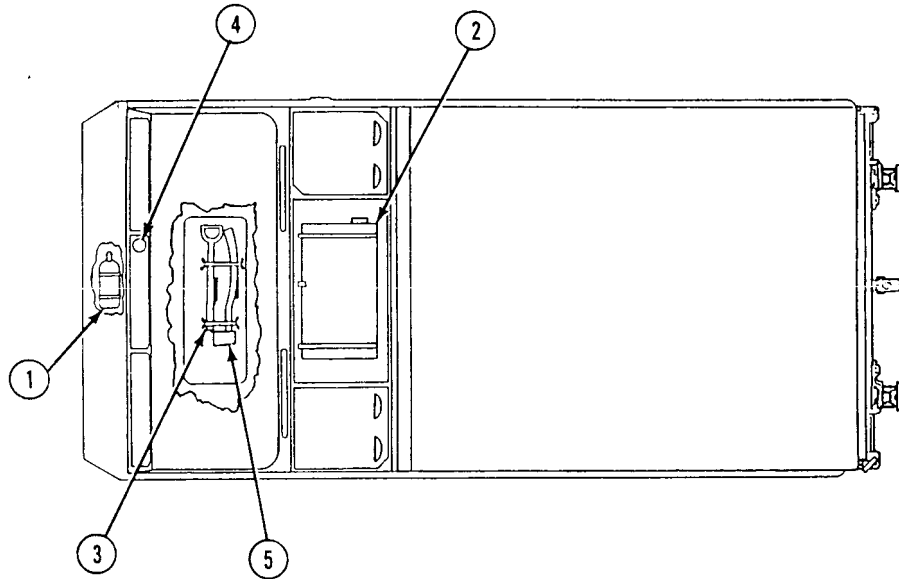

STRAP KEY				
NO.	ITEM	QTY	LENGTH (INCHES)	WIDTH (INCHES)
1	Fire extinguisher	1	24	1
2	Axe (under seat)	1	16	1
3	Mattock handle (under seat)	1	16	
4	Oil can			
5	Windows stowage container			

STOWAGE GUIDE — M548A3

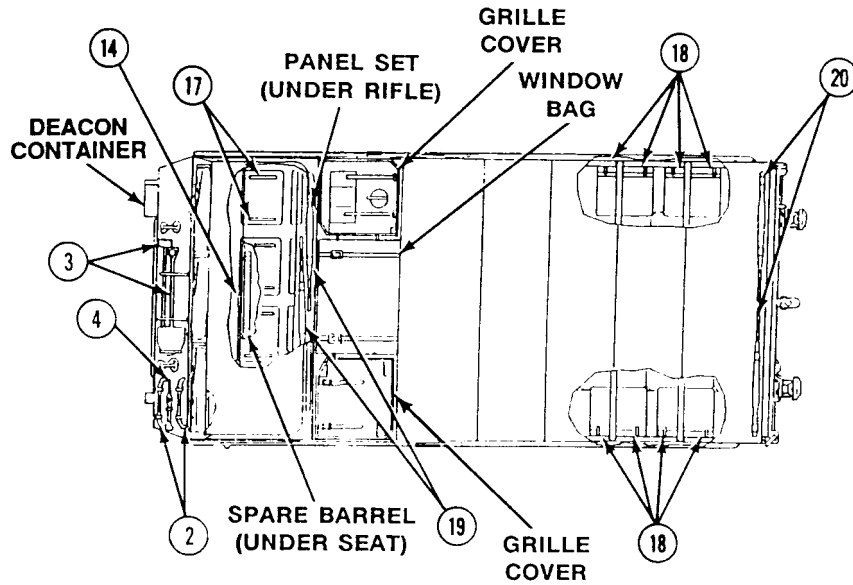
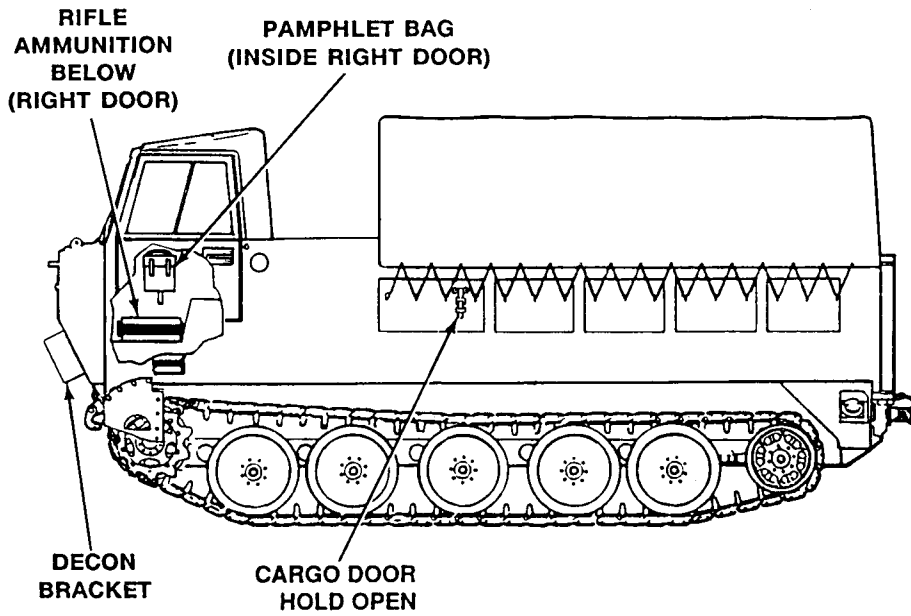

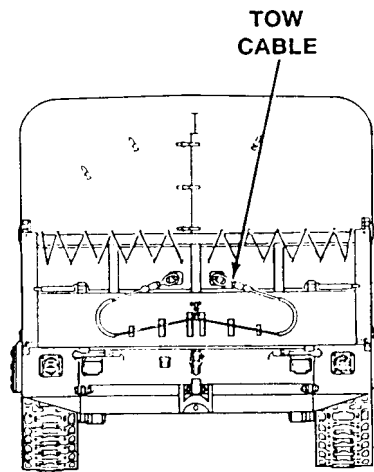

STOWAGE GUIDE—Continued

0084 00

STRAP KEY				
NO.	ITEM	QTY	LENGTH (INCHES)	WIDTH (INCHES)
1	Crowbar	2	20	1
2	Track fixtures	2	28	1
3	Shovel, and sledge	2	36	1
4	Mattock head	1	18	1
5	Machine gun ammo boxes	4	48	1
6	Tow cable	1	24	1
7	Fire extinguisher	1	24	1
8	First aid kit	1	24	1
9	Water can	1	60	1-1/2
10	Water can	1	54	1-1/2
11	Tool bag	2		
12	Machine gun spare barrel	2	24	1
13	Cargo door hold-open	1	18	1
14	Center seat support	1	26	1
15	Rifle ammo boxes	3	45	1
*16	Hoist chains	1	36	1
17	Seat cushions, cab	6	28	1
*18	Seat cushions, cargo area	8	33	1
19	Rifle (crew)	2		
*20	Rifles (cargo compartment)	6		
*21	Decon container	1		
* Used with special purpose kits				

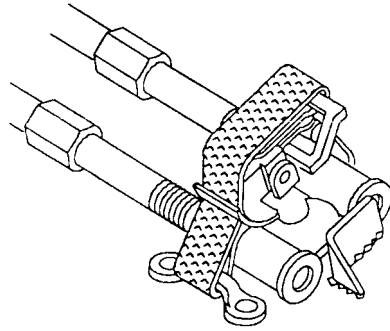
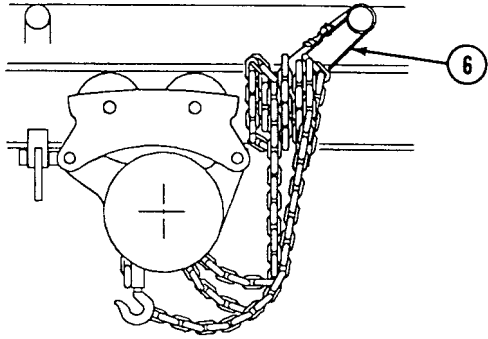

PROPER METHOD OF STRAPPING,
MAKE CERTAIN BOTH LOOPS PASS
OVER TOP OF SECURED ITEM.

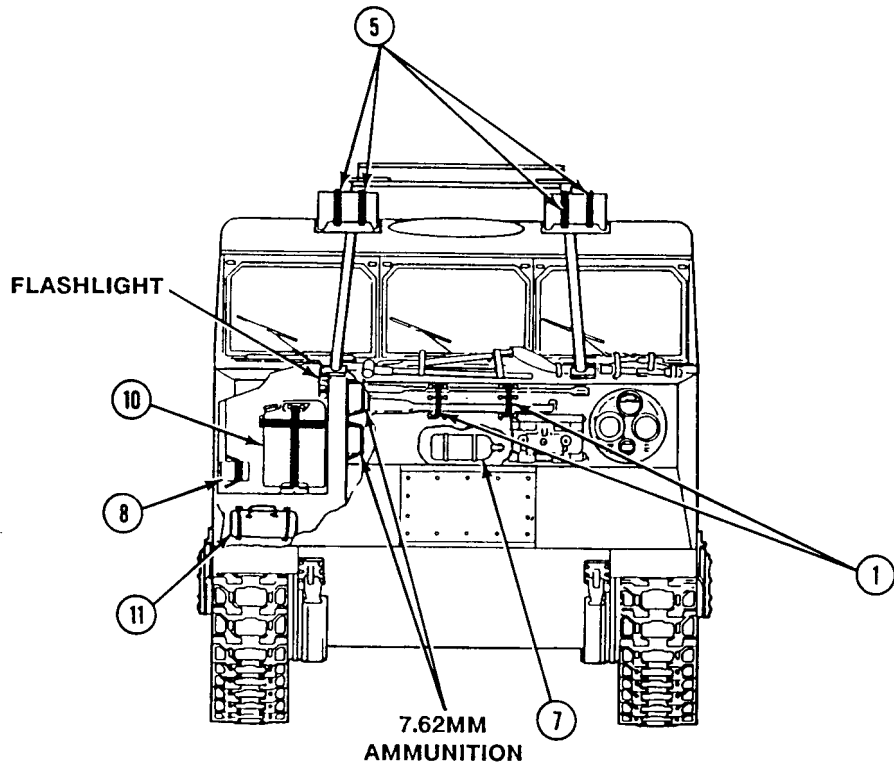

INDEX

Subject WP Sequence No.-Page No.

A

Access Covers

Hull Bottom

- Installation 0076 00-4
- Removal 0076 00-1

Power Plant Rear

- Install Lower Rear Access Cover (M548A1) 0036 00-3
- Install Rear Access Panel (M548A3) 0036 00-5
- Install Right Access Cover 0036 00-2
- Install Upper Rear Access Door (M548A1) 0036 00-4
- Remove Lower Rear Access Cover (M548A1) 0036 00-3
- Remove Rear Access Panel (M548A3) 0036 00-4
- Remove Right Access Cover 0036 00-1
- Remove Upper Rear Access Door (M548A1) 0036 00-2

Additional Authorization List (AAL) 0082 00-1

Air Brake Kit (M548A1)

Inspection-Acceptance and Rejection Criteria

- Air Couplings 0075 00-1
- Air Reservoir 0075 00-3
- Compressor Drive Belts 0075 00-3
- Instrument Panel 0075 00-2
- Treadle Valve Pedal 0075 00-2

- Operation 0028 00-1
- Troubleshooting Table 0056 00-1

Air Cleaner Element

- Cleaning 0063 00-2
- Installation 0063 00-3
- Removal 0063 00-1

Air Cleaner Element Door Maintenance (M548A3)

- Installation 0064 00-2
- Removal 0064 00-1

Air Filter System, NBC (M548A3)

Operation

- Start 0053 00-2
- Stop 0053 00-5

Air Intake and Exhaust Grille Covers

M548A1

- Installation 0026 00-1
- Removal 0026 00-3

M548A3

- Installation 0027 00-1
- Removal 0027 00-1

INDEX, cont'd

<u>Subject</u>	<u>WP Sequence No.-Page No.</u>
Air Separator Tank	
Drain	0069 00-1
B	
Batteries	
Maintenance	0070 00-2
Bilge Pump	
Check Operation	0073 00-2
Clean	0073 00-1
Troubleshooting Table	0056 00-3
Brake, Parking (M548A3)	
Adjust	0012 00-2
Release	0012 00-1
Set	0012 00-1
Bulkhead Protector	
Installation	0078 00-2
Removal	0078 00-1
Bypass Defective Transmission Controller (M548A3)	0047 00-1
C	
Cab Doors and Windows	
Close Cab Doors	0009 00-2
Open Cab Doors	0009 00-1
Open/Close Cab Windows	0009 00-2
Cargo Compartment	
Door	
Close	0005 00-3
Open	0005 00-2
Floor Plates	
Installation	0007 00-3
Removal	0007 00-1
Cargo, Load	
General Precautions	0017 00-1
Getting Carrier Ready	0017 00-1
Loading Ammunition Supply	0017 00-2
Carrier Lights	
Operate Blackout Marker	0032 00-3
Operate Blackout Marker and Blackout Driving Lights	0032 00-4
Operate Headlights	0032 00-1
Operate Infrared Headlights	0032 00-5
Operate Panel and Transmission Controller Lights	0032 00-6
Operate Stop Light	0032 00-5

INDEX, cont'd

<u>Subject</u>	<u>WP Sequence No.-Page No.</u>
Compartment Access Door	
Lower	0037 00-2
Raise	0037 00-1
Compartment Heater Kit	
Cargo Area (Secondary)	
Close Rear Curtain	0008 00-3, 0008 00-7
Close Ventilation Curtain	0008 00-5
Open Rear Curtain	0008 00-2
Open Ventilation Curtain	0008 00-4
Open Window Curtain	0008 00-6
Components of End Item and Basic Issue Items	0081 00-1
Controls and Instruments	
Bilge Pump (M548A1)	0004 00-6
Bilge Pump (M548A3)	0004 00-13
Cargo Compartment Door and Tailgate	0004 00-21
Carrier Brakes (M548A3)	0004 00-9
Compartment Heater	0004 00-16
Driver's (M548A1)	0004 00-1
Driver's (M548A3)	0004 00-8
Driver's Seat	0004 00-15
Driving Lights	0004 00-18
Engine Coolant Heater	0004 00-17
Fire Extinguisher, Fixed	0004 00-19
Fire Extinguisher, Portable	0004 00-20
Instrument Panel (M548A1)	0004 00-4
Instrument Panel (M548A3)	0004 00-11
Lights, Carrier	0004 00-18
Master Switch	0004 00-15
Parking Brake (M548A3)	0004 00-8
Parking Brakes (M548A1)	0004 00-1
Transmission Range Selector (M548A1)	0004 00-3
Transmission Shift Controller (M548A3)	0004 00-10
Coolant Heater Kit	
Operation (M548A1)	0040 00-1
Operation (M548A3)	0041 00-1
Cooling System	
Operational Check (M548A1)	
Coolant Level, Check/Fill,	0065 00-1
Operational Check (M548A3)	
Coolant Level, Check/Fill,	0066 00-2

INDEX, cont'd

<u>Subject</u>	<u>WP Sequence No.-Page No.</u>
Covers	
Air Intake and Exhaust Grille	
M548A1	
Installation	0026 00-1
Removal	0026 00-3
M548A3	
Installation	0027 00-1
Removal	0027 00-1
Drain	
Installation	0076 00-4
Removal	0076 00-1
Hull Bottom Access	
Installation	0076 00-4
Removal	0076 00-1
Top Access and Grilles (M548A3)	
Installation	0006 00-2
Removal	0006 00-1
Covers, Cab	
Cab Side Windows	
Removal/Installation	0072 00-4
Escape Hatch Cover	
Installation	0072 00-2
Removal	0072 00-1
Window Stowage	0072 00-3
Windshield Sections	
Removal/Installation	0072 00-3
Covers, Cargo	
Closure Flaps	0071 00-5
Escape Hatch Cover	0071 00-6
Installation	0071 00-3
Removal	0071 00-1
D	
Differential (M548A1)	
Troubleshooting Table	0056 00-5
Drive Belts	
M548A1	
Operational Check	0067 00-1
M548A3	
Operational Check	0068 00-1
Drive Carrier	
M548A1	
Drive Carrier	0020 00-3
Driving Precautions	0020 00-1
Select Driving Range	0020 00-11

INDEX, cont'd

<u>Subject</u>	<u>WP Sequence No.-Page No.</u>
M548A3	
Drive Carrier	0021 00-4
Driving Precautions	0021 00-2
Electrical Power Failure	0016 00-1
Select Driving Range	0021 00-10
Transmission Controller Failure	0016 00-1
Driver's Seat	
Adjustment	0010 00-1
E	
Electrical System	
Troubleshooting Table	0056 00-7
Engine	
Troubleshooting Table	0056 00-9
Engine Coolant Heater Kit	
Operation (M548A1)	0040 00-1
Operation (M548A3)	0041 00-1
Troubleshooting Table	0056 00-13
Engine Stopping	
M548A1	0023 00-1
M548A3	0024 00-1
Engine, Start	
External Power <input type="checkbox"/>	<input type="checkbox"/> 0015 00-1
Engine, Starting	
M548A1	
Above 40 Degrees	0013 00-2
Below 40 Degrees	0013 00-6
M548A3	
Above 40 Degrees	0014 00-2
Below 40 Degrees	0014 00-8
Equipment Description	0002 00-1
Carrier	0002 00-1
Locational Terms	0002 00-1
Expendable/Durable Supplies and Materials List	0083 00-1
F	
Final Drive	
Troubleshooting Table	0056 00-15

INDEX, cont'd

<u>Subject</u>	<u>WP Sequence No.-Page No.</u>
Fire Extinguisher	
Fixed	
Operate (Inside)	0033 00-3
Operate (Outside)	0033 00-1
Portable	
Operation	0034 00-1
Floor Plates	
Cab	
Lower	0077 00-3
Raise	0077 00-1
Cargo Compartment	
Installation	0007 00-3
Removal	0007 00-1
Ford Water	
Post-fording Operations	0044 00-1
Pre-fording Operations	0042 00-1
Up to 40 Inches Deep	0043 00-1
Fuel System	
Drain Fuel Filters	0069 00-1
Fuel Carrier	0025 00-1
G	
General Information	
Destruction of Army Material to Prevent Enemy Use	0001 00-3
List of Abbreviations/Acronyms	0001 00-3
Maintenance Forms and Records	0001 00-2
Nomenclature Cross Reference List	0001 00-3
Reporting Equipment Improvement Recommendations	0001 00-2
Safety, Care, and Handling	0001 00-4
Scope	0001 00-1
I	
Instrument Panel	
Check Instrument Panel (M548A1)	0018 00-1
Check Instrument Panel (M548A3)	0019 00-1
L	
Load Cargo	
General Precautions	0017 00-1
Getting Carrier Ready	0017 00-1
Loading Ammunition Supply	0017 00-2
Load, Towed	
Connect	0048 00-1

INDEX, cont'd

<u>Subject</u>	<u>WP Sequence No.-Page No.</u>
M	
Machine Gun Ammunition	
Classification and Identification	0079 00-1
Machine Gun Mounting Kits	
7.62 MM	
Installation	0035 00-4
Mount Controls	0035 00-4
Removal	0035 00-5
M49A1	
Installation	0035 00-3
Mount Controls	0035 00-2
Removal	0035 00-4
M66	
Adjustment	0074 00-1
Installation	0035 00-2
Mount Controls	0035 00-1
Removal	0035 00-2
Troubleshooting Table	0056 00-17
Material Handling Kit	
Adjustment	0029 00-1
Prepare Hoist for Travel	0029 00-4
Troubleshooting Table	0056 00-19
Use Hoist	0029 00-3
N	
NBC Air Filter System (M548A3)	
Operation	
Start	0053 00-2
Stop	0053 00-5
NBC Kit (M548A3)	
Troubleshooting Table	0056 00-21
O	
Operate Carrier In Extreme Heat, Humidity, Salty Conditions	
Operation	0046 00-1
Operating Carrier In Extreme Cold	
Do's	0039 00-2
Don'ts	0039 00-3
Start Engine in Extreme Cold	0039 00-3
Stop Engine in Extreme Cold	0039 00-3

INDEX, cont'd

<u>Subject</u>	<u>WP Sequence No.-Page No.</u>
Operating Carrier Over Rough Terrain	
Drive Carrier On Grades	0045 00-3
Drive Carrier On Side Slopes	0045 00-4
Drive Carrier On Snow, Ice, or Mud	0045 00-5
Drive Carrier Over Obstacles	0045 00-3
Drive Carrier Over Trenches	0045 00-2
Park Carrier On Snow, Ice, or Mud	0045 00-5
 P 	
Parking Brake (M548A3)	
Adjust	0012 00-2
Release	0012 00-1
Set	0012 00-1
Power Plant	
Rear Access Cover	
Install Lower Rear Access Cover (M548A1)	0036 00-3
Install Rear Access Panel (M548A3)	0036 00-5
Install Right Access Cover	0036 00-2
Install Upper Rear Access Door (M548A1)	0036 00-4
Remove Lower Rear Access Cover (M548A1)	0036 00-3
Remove Rear Access Panel (M548A3)	0036 00-4
Remove Right Access Cover	0036 00-1
Remove Upper Rear Access Door (M548A1)	0036 00-2
Preventive Maintenance Checks and Services (PMCS)	0057 00-1
 R 	
Rifle Ammunition	
Classification and Identification	0079 00-1
 S 	
Seats, Cab Personnel	
Lower Center Seat	0011 00-2
Lower Driver's Seat	0011 00-3
Raise Center Seat	0011 00-1
Raise Driver's Seat	0011 00-2
Sprocket Wear, T130	
Inspection	0062 00-1
Start Carrier (M548A3)	
Electric Power Failure	0016 00-2
Transmission Controller Failure	0016 00-2

INDEX, cont'd

<u>Subject</u>	<u>WP Sequence No.-Page No.</u>
Start Engine	
External Power □	□ 0015 00-1
M548A1	
Above 40 Degrees	0013 00-2
Below 40 Degrees	0013 00-6
M548A3	
Above 40 Degrees	0014 00-2
Below 40 Degrees	0014 00-8
Stop Engine	
M548A1	0023 00-1
M548A3	0024 00-1
Stowage guide	0084 00-1
Symptom Index	
Troubleshooting	0055 00-1
T	
Tailgate	
Close	0005 00-5
Open	0005 00-4
Theory of Operation	0003 00-1
Tow Start Disabled Carrier	
M548A1	0051 00-2
M548A3	0052 00-1
Towed Load	
Connect	0048 00-1
Towing Disabled Carrier	
M548A1	
Install Tow Bar on Disabled Carrier and Recovery Vehicle	0049 00-1
Install Tow Cables on Disabled Carrier and Recovery Vehicle	0049 00-4
Remove Tow Bar From Disabled Carrier and Recovery Vehicle	0049 00-6
Remove Tow Cables From Disabled Carrier and Recovery Vehicle	0049 00-7
Tow Disabled Carrier	0049 00-4
M548A3	
Install Tow Bar on Disabled Carrier and Recovery Vehicle	0050 00-2
Install Tow Cables on Disabled Carrier and Recovery Vehicle	0050 00-4
Remove Tow Bar From Disabled Carrier and Recovery Vehicle	0050 00-6
Remove Tow Cables From Disabled Carrier and Recovery Vehicle	0050 00-8
Tow Disabled Carrier	0050 00-5

INDEX, cont'd

<u>Subject</u>	<u>WP Sequence No.-Page No.</u>
Track	
T130	
Adjustment	0058 00-5
Break	0059 00-1
Inspection	0058 00-1
Join	0059 00-6
T150	
Break	0059 01-1
Join	0059 01-6
Track Pad	
Bumper Mounted (T130 Track)	
Replace	0061 00-2
T130	
Installation	0061 00-1
Removal	0061 00-1
Track Shoe	
T130	
Installation	0060 00-3
Removal	0060 00-1
T150	
Installation	0060 01-2
Removal	0060 01-1
Track Shoe Wear Limits	
Inspection	0061 01-1
Track Tension	
T150 Track	
Adjust	0058 01-1
Tracks	
Block Carrier Tracks	0038 00-1
Unblock Carrier Tracks	0038 00-2
Tracks and Suspensions	
Troubleshooting Table	0056 00-23
Transfer Gearcase	
Troubleshooting Table	0056 00-25
Transmission	
Troubleshooting Table	0056 00-27
Transmission Controller (M548A3)	
Bypass	0047 00-1

INDEX, cont'd

<u>Subject</u>	<u>WP Sequence No.-Page No.</u>
Troubleshooting	
Air Brake Kit	0056 00-1
Bilge Pump	0056 00-3
Differential (M548A1)	0056 00-5
Electrical System	0056 00-7
Engine	0056 00-9
Engine Coolant Heater Kit	0056 00-13
Final Drive	0056 00-15
Introduction	0054 00-1
Machine Gun Mounting Kits	0056 00-17
Material Handling Kit	0056 00-19
NBC Kit (M548A3)	0056 00-21
Symptom Index	0055 00-1
Tracks and Suspensions	0056 00-23
Transfer Gearcase	0056 00-25
Transmission	0056 00-27
Turn Signal Kit	0056 00-29
Vehicle Compartment Heater Kit	0056 00-31
Winch (M548A1)	0056 00-33
 Troubleshooting Table	 0056 00-1
 Turn Signal Kit	
Operation	0022 00-1
Troubleshooting Table	0056 00-29
 V 	
Vehicle and Cargo Compartment Heater	
Operate Defroster Fans	0031 00-3
Operate Heat Manifold Control	0031 00-2
Operate Heat Regulator Control	0031 00-3
Operate Heater	0031 00-1
 Vehicle Compartment Heater Kit	
Troubleshooting Table	0056 00-31
 W 	
Winch (M548A1)	
Troubleshooting Table	0056 00-33
 Winch Operation (M548A1)	
Reel In Wire Rope	0030 00-3
Reel Out Wire Rope	0030 00-1
Wind Wire Rope	0030 00-5

RECOMMENDED CHANGES TO PUBLICATIONS AND BLANK FORMS For use of this form, see AR 25-30; the proponent agency is ODISC4.	Use Part II (reverse) for Repair Parts and Special Tools Lists (RPSTL) and Supply Catalogs/Supply Manuals SC/SM).	Date
TO: (Forward to proponent of publication or form) (Include ZIP Code)	FROM: (Activity and location) (include ZIP code)	

PART I – ALL PUBLICATIONS (EXCEPT RPSTL AND SC/SM) AND BLANK FORMS

PUBLICATION/FORM NUMBER TM 9-2350-247-10	DATE 30 June 2001	TITLE Operator's Manual for Carrier, Cargo Tracked, 6-Ton M548A1 and M548A3
--	-----------------------------	---

ITEM	PAGE	PARA	LINE	FIGURE NO.	TABLE	RECOMMENDED CHANGES AND REASON
0052 00-4						Inspection Step 1 WP reference should be (WP 0003 00) <div style="text-align: center; font-size: 4em; opacity: 0.5;"> SAMPLE </div>

**Reference to line numbers within the paragraph or subparagraph.*

TYPED, GRADE OR TITLE	TELEPHONE EXCHANGE/AUTOVON, PLUS EXTENSION	SIGNATURE
-----------------------	--	-----------

TO: (Forward direct to addressee listed in publication)	FROM: (Activity and location) (Include Zip Code)	Date
--	---	-------------

PART II – REPAIR PARTS AND SPECIAL TOOL LISTS AND SUPPLY CATALOGS/SUPPLY MANUALS

PUBLICATION NUMBER TM 9-2350-247-10	DATE 30 June 2001	TITLE Operator's Manual for Carrier, Cargo Tracked, 6-Ton M548A1 and M548A3
---	-----------------------------	---

PAGE NO.	COLM NO.	LINE NO.	NATIONAL STOCK NUMBER	REFERENCE NO.	FIGURE NO.	ITEM NO.	TOTAL NO. OF MAJOR ITEMS SUPPORTED	RECOMMENDED ACTION

PART III – REMARKS (Any general remarks or recommendations, or suggestions for improvement of publications and blank forms. Additional blank sheets may be used if more space is needed).

SAMPLE

TYPED, GRADE OR TITLE	TELEPHONE EXCHANGE/AUTOVON, PLUS EXTENSION	SIGNATURE
-----------------------	--	-----------

RECOMMENDED CHANGES TO PUBLICATIONS AND BLANK FORMS For use of this form, see AR 25-30; the proponent agency is ODISC4.	Use Part II (reverse) for Repair Parts and Special Tools Lists (RPSTL) and Supply Catalogs/Supply Manuals SC/SM).	Date
TO: <i>(Forward to proponent of publication or form) (Include ZIP Code)</i>		FROM: <i>(Activity and location) (include ZIP code)</i>

PART I – ALL PUBLICATIONS (EXCEPT RPSTL AND SC/SM) AND BLANK FORMS

PUBLICATION/FORM NUMBER TM 9-2350-247-10	DATE 30 June 2001	TITLE Operator's Manual for Carrier, Cargo Tracked, 6-Ton M548A1 and M548A3
--	-----------------------------	---

ITEM	PAGE	PARA	LINE	FIGURE NO.	TABLE	RECOMMENDED CHANGES AND REASON

**Reference to line numbers within the paragraph or subparagraph.*

TYPED, GRADE OR TITLE	TELEPHONE EXCHANGE/AUTOVON, PLUS EXTENSION	SIGNATURE
-----------------------	---	-----------

TO: (Forward direct to addressee listed in publication)	FROM: (Activity and location) (Include Zip Code)	Date
--	---	-------------

PART II – REPAIR PARTS AND SPECIAL TOOL LISTS AND SUPPLY CATALOGS/SUPPLY MANUALS

PUBLICATION NUMBER TM 9-2350-247-10	DATE 30 June 2001	TITLE Operator's Manual for Carrier, Cargo Tracked, 6-Ton M548A1 and M548A3
---	-----------------------------	---

PAGE NO.	COLM NO.	LINE NO.	NATIONAL STOCK NUMBER	REFERENCE NO.	FIGURE NO.	ITEM NO.	TOTAL NO. OF MAJOR ITEMS SUPPORTED	RECOMMENDED ACTION

PART III – REMARKS *(Any general remarks or recommendations, or suggestions for improvement of publications and blank forms. Additional blank sheets may be used if more space is needed).*

TYPED, GRADE OR TITLE	TELEPHONE EXCHANGE/AUTOVON, PLUS EXTENSION	SIGNATURE
-----------------------	--	-----------

RECOMMENDED CHANGES TO PUBLICATIONS AND BLANK FORMS For use of this form, see AR 25-30; the proponent agency is ODISC4.	Use Part II (reverse) for Repair Parts and Special Tools Lists (RPSTL) and Supply Catalogs/Supply Manuals SC/SM).	Date
TO: <i>(Forward to proponent of publication or form) (Include ZIP Code)</i>		FROM: <i>(Activity and location) (include ZIP code)</i>

PART I – ALL PUBLICATIONS (EXCEPT RPSTL AND SC/SM) AND BLANK FORMS

PUBLICATION/FORM NUMBER TM 9-2350-247-10	DATE 30 June 2001	TITLE Operator's Manual for Carrier, Cargo Tracked, 6-Ton M548A1 and M548A3
--	-----------------------------	---

ITEM	PAGE	PARA	LINE	FIGURE NO.	TABLE	RECOMMENDED CHANGES AND REASON

**Reference to line numbers within the paragraph or subparagraph.*

TYPED, GRADE OR TITLE	TELEPHONE EXCHANGE/AUTOVON, PLUS EXTENSION	SIGNATURE
-----------------------	---	-----------

TO: (Forward direct to addressee listed in publication)	FROM: (Activity and location) (Include Zip Code)	Date
--	---	-------------

PART II – REPAIR PARTS AND SPECIAL TOOL LISTS AND SUPPLY CATALOGS/SUPPLY MANUALS

PUBLICATION NUMBER TM 9-2350-247-10				DATE 30 June 2001			TITLE Operator's Manual for Carrier, Cargo Tracked, 6-Ton M548A1 and M548A3	
PAGE NO.	COLM NO.	LINE NO.	NATIONAL STOCK NUMBER	REFERENCE NO.	FIGURE NO.	ITEM NO.	TOTAL NO. OF MAJOR ITEMS SUPPORTED	RECOMMENDED ACTION

PART III – REMARKS *(Any general remarks or recommendations, or suggestions for improvement of publications and blank forms. Additional blank sheets may be used if more space is needed).*

TYPED, GRADE OR TITLE	TELEPHONE EXCHANGE/AUTOVON, PLUS EXTENSION	SIGNATURE
-----------------------	--	-----------

RECOMMENDED CHANGES TO PUBLICATIONS AND BLANK FORMS For use of this form, see AR 25-30; the proponent agency is ODISC4.	Use Part II (reverse) for Repair Parts and Special Tools Lists (RPSTL) and Supply Catalogs/Supply Manuals SC/SM).	Date
TO: <i>(Forward to proponent of publication or form) (Include ZIP Code)</i>		FROM: <i>(Activity and location) (include ZIP code)</i>

PART I – ALL PUBLICATIONS (EXCEPT RPSTL AND SC/SM) AND BLANK FORMS

PUBLICATION/FORM NUMBER TM 9-2350-247-10	DATE 30 June 2001	TITLE Operator's Manual for Carrier, Cargo Tracked, 6-Ton M548A1 and M548A3
--	-----------------------------	---

ITEM	PAGE	PARA	LINE	FIGURE NO.	TABLE	RECOMMENDED CHANGES AND REASON

**Reference to line numbers within the paragraph or subparagraph.*

TYPED, GRADE OR TITLE	TELEPHONE EXCHANGE/AUTOVON, PLUS EXTENSION	SIGNATURE
-----------------------	---	-----------

TO: (Forward direct to addressee listed in publication)	FROM: (Activity and location) (Include Zip Code)	Date
--	---	-------------

PART II – REPAIR PARTS AND SPECIAL TOOL LISTS AND SUPPLY CATALOGS/SUPPLY MANUALS

PUBLICATION NUMBER TM 9-2350-247-10	DATE 30 June 2001	TITLE Operator's Manual for Carrier, Cargo Tracked, 6-Ton M548A1 and M548A3
---	-----------------------------	---

PAGE NO.	COLM NO.	LINE NO.	NATIONAL STOCK NUMBER	REFERENCE NO.	FIGURE NO.	ITEM NO.	TOTAL NO. OF MAJOR ITEMS SUPPORTED	RECOMMENDED ACTION

PART III – REMARKS *(Any general remarks or recommendations, or suggestions for improvement of publications and blank forms. Additional blank sheets may be used if more space is needed).*

TYPED, GRADE OR TITLE	TELEPHONE EXCHANGE/AUTOVON, PLUS EXTENSION	SIGNATURE
-----------------------	--	-----------

RECOMMENDED CHANGES TO PUBLICATIONS AND BLANK FORMS For use of this form, see AR 25-30; the proponent agency is ODISC4.	Use Part II (reverse) for Repair Parts and Special Tools Lists (RPSTL) and Supply Catalogs/Supply Manuals SC/SM).	Date
TO: <i>(Forward to proponent of publication or form) (Include ZIP Code)</i>		FROM: <i>(Activity and location) (include ZIP code)</i>

PART I – ALL PUBLICATIONS (EXCEPT RPSTL AND SC/SM) AND BLANK FORMS

PUBLICATION/FORM NUMBER				DATE		TITLE
TM 9-2350-247-10				30 June 2001		Operator's Manual for Carrier, Cargo Tracked, 6-Ton M548A1 and M548A3
ITEM	PAGE	PARA	LINE	FIGURE NO.	TABLE	RECOMMENDED CHANGES AND REASON

**Reference to line numbers within the paragraph or subparagraph.*

TYPED, GRADE OR TITLE	TELEPHONE EXCHANGE/AUTOVON, PLUS EXTENSION	SIGNATURE

TO: (Forward direct to addressee listed in publication)	FROM: (Activity and location) (Include Zip Code)	Date
--	---	-------------

PART II – REPAIR PARTS AND SPECIAL TOOL LISTS AND SUPPLY CATALOGS/SUPPLY MANUALS

PUBLICATION NUMBER TM 9-2350-247-10	DATE 30 June 2001	TITLE Operator's Manual for Carrier, Cargo Tracked, 6-Ton M548A1 and M548A3
---	-----------------------------	---

PAGE NO.	COLM NO.	LINE NO.	NATIONAL STOCK NUMBER	REFERENCE NO.	FIGURE NO.	ITEM NO.	TOTAL NO. OF MAJOR ITEMS SUPPORTED	RECOMMENDED ACTION

PART III – REMARKS *(Any general remarks or recommendations, or suggestions for improvement of publications and blank forms. Additional blank sheets may be used if more space is needed).*

TYPED, GRADE OR TITLE	TELEPHONE EXCHANGE/AUTOVON, PLUS EXTENSION	SIGNATURE
-----------------------	--	-----------

By Order of the Secretary of the Army:

Official

JOEL B. HUDSON
*Administrative Assistant to the
Secretary of the Army*
0105106

ERIC K. SHINSEKI
*General, United States Army
Chief of Staff*

DISTRIBUTION:

To be distributed in accordance with the initial distribution number (IDN) 370824,
requirements for TM 9-2350-247-10.

THE METRIC SYSTEM AND EQUIVALENTS

LINEAR MEASURE

1 Centimeter = 10 Millimeters = 0.01 Meters = 0.3937 Inches
 1 Meter = 100 Centimeters = 1000 Millimeters = 39.37 Inches
 1 Kilometer = 1000 Meters = 0.621 Miles

WEIGHTS

1 Gram = 0.001 Kilograms = 1000 Milligrams = 0.035 Ounces
 1 Kilogram = 1000 Grams = 2.2 Lb.
 1 Metric Ton = 1000 Kilograms = 1 Megagram = 1.1 Short Tons

LIQUID MEASURE

1 Milliliter = 0.001 Liters = 0.0338 Fluid Ounces
 1 Liter = 1000 Milliliters = 33.82 Fluid Ounces

SQUARE MEASURE

1 Sq. Centimeter = 100 Sq. Millimeters = 0.155 Sq. Inches
 1 Sq. Meter = 10,000 Sq. Centimeters = 10.76 Sq. Feet
 1 Sq. Kilometer = 1,000 Sq. Meters = 0.386 Sq. Miles

CUBIC MEASURE

1 Cu. Centimeter = 1000 Cu. Millimeters = 0.06 Cu. Inches
 1 Cu. Meter = 1,000,000 Cu. Centimeters = 35.31 Cu. Feet

TEMPERATURE

$5/9 (^{\circ}\text{F} - 32) = ^{\circ}\text{C}$
 212° Fahrenheit is equivalent to 100° Celsius
 90° Fahrenheit is equivalent to 32.2° Celsius
 32° Fahrenheit is equivalent to 0° Celsius
 $(9/5 \times ^{\circ}\text{C}) + 32 = ^{\circ}\text{F}$

TO CHANGE	TO	MULTIPLY BY
Inches	Centimeters.....	2.540
Feet	Meters.....	0.305
Yards	Meters.....	0.914
Miles.....	Kilometers	1.609
Square Inches	Square Centimeters.....	6.451
Square Feet	Square Meters.....	0.093
Square Yards	Square Meters.....	0.836
Square Miles.....	Square Kilometers	2.590
Acres.....	Square Hectometers.....	0.405
Cubic Feet	Cubic Meters	0.028
Cubic Yards.....	Cubic Meters	0.765
Fluid Ounces	Millimeters	29.573
Pints.....	Liters.....	0.473
Quarts	Liters.....	0.946
Gallons	Liters	3.785
Ounces	Grams	28.349
Pounds.....	Kilograms	0.454
Short Tons	Metric Tons	0.907
Pound-Feet.....	Newton-Meters	1.356
Pounds per Square Inch	Kilopascals	6.895
Miles per Gallon	Kilometers per Liter.....	0.425
Miles per Hour.....	Kilometers per Hour	1.609

TO CHANGE	TO	MULTIPLY BY
Centimeters.....	Inches	0.394
Meters.....	Feet	3.280
Meters.....	Yards	1.094
Kilometers	Miles.....	0.621
Square Centimeters.....	Square Inches.....	0.155
Square Meters.....	Square Feet	10.764
Square Meters.....	Square Yards	1.196
Square Kilometers	Square Miles.....	0.386
Square Hectometers.....	Acres.....	2.471
Cubic Meters	Cubic Feet	35.315
Cubic Meters	Cubic Yards.....	1.308
Milliliters	Fluid Ounces.....	0.034
Liters.....	Pints.....	2.113
Liters.....	Quarts	1.057
Liters.....	Gallons.....	0.264
Grams	Ounces.....	0.035
Kilograms	Pounds.....	2.205
Metric Tons	Short Tons	1.102
Newton-Meters	Pound-Feet.....	0.738
Kilopascals	Pounds per Square Inch	0.145
Kilometers per Liter.....	Miles per Gallon	2.354
Kilometers per Hour	Miles per Hour.....	0.621

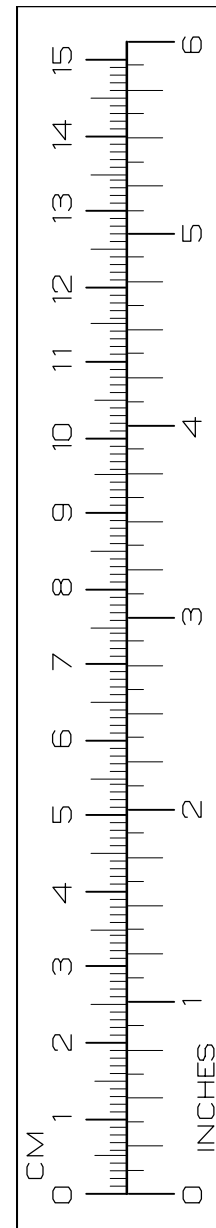

PIN: 028680-000